

KRONOS 208V
10-40kVAUPS
Installation and Operation Manual

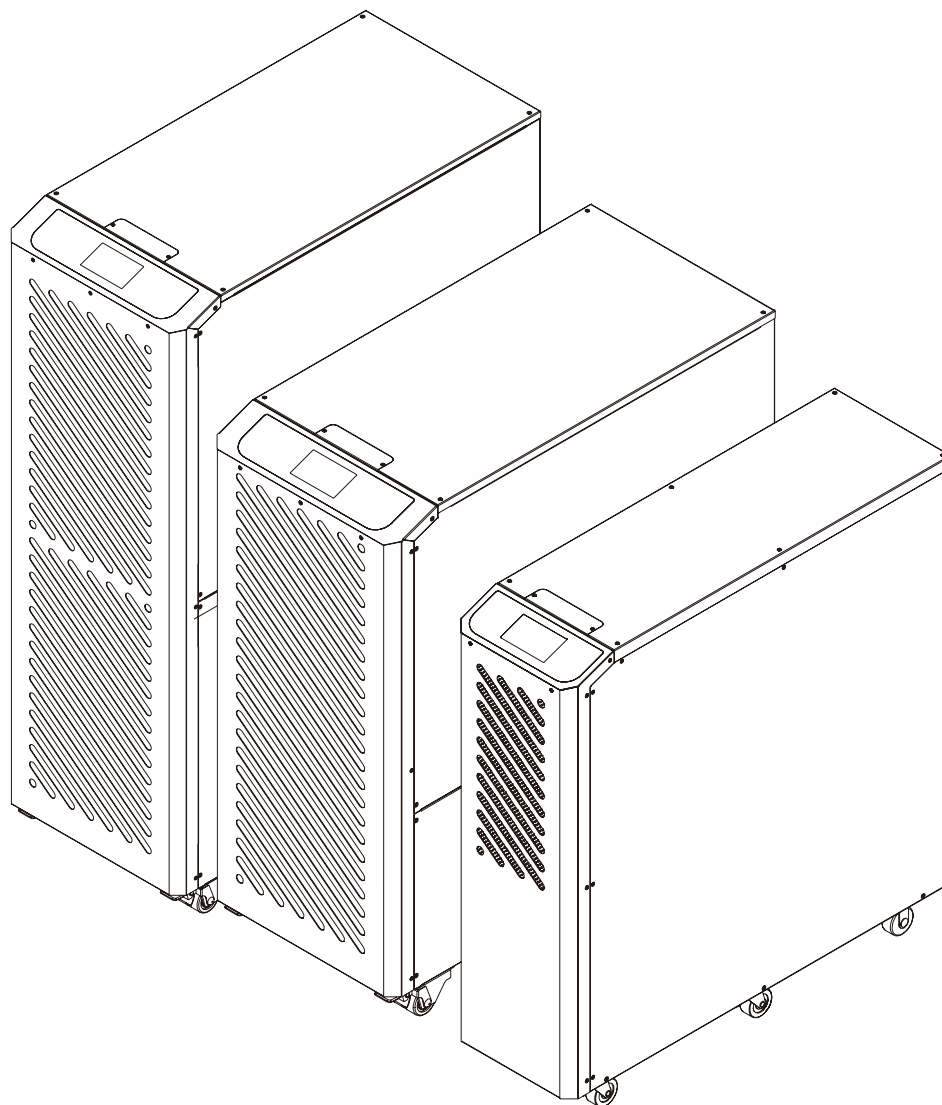

CONTENTS

Preface	1
Safety	2
1. Function Description.....	5
1.1 UPS Block Diagram.....	5
1.2 UPS Front View	6
2. Installation and Wiring.....	20
2.1 Storage and Installation Environment.....	20
2.2 Unpacking, Removing and Securing UPS	21
2.3 General Requirements for Ventilation and Maintenance	30
2.4 Power Cables Connections.....	31
2.5 Auxiliary Power Supply Control Switch and Precharge Button.....	39
2.6 Communication Cables Connections	40
2.7 UPS Parallel Connections (Option)	44
3. Kronos Operation And Descriptions.....	48
3.1 Operating Mode.....	48
3.2 Online Operations	49
3.3 Manual Bypass Operation.....	49
3.4 Operating Processes	50
4. Control Panel Operation and Function Description.....	54
4.1 Screen Introduction	54
4.2 Menu.....	55
4.3 Mimic Display.....	60
5. Options	61
5.1 Dry Contact Card	61
5.2 RS-485 MODBUS Card.....	61
5.3 SNMP Card	61
5.4 Temperature Sensor	62
5.5 Parallel Communication Card.....	62
6. Troubleshooting.....	63
6.1 Export machine information from LCD panel	63
6.2 Exporting The event log from LCD panel.....	64
7. Technical Specifications.....	65
Appendix	67

Preface

We thank you for the trust in selecting our Kronos UPS.

The purpose of this manual is to introduce the user to the operating principles of the Kronos UPS and to provide instructions in its safe operation. The manual also provides troubleshooting assistance should an abnormal message or behavior occur.

Should an abnormal message not covered in this manual appear, contact your local authorized service agent for troubleshooting and repair.

All of the installation, operation, and maintenance of this device must be performed by authorized and qualified technicians who are familiar with this UPS.

Safety

SAVE THESE INSTRUCTIONS - This manual contains important instructions that should be followed during installation and maintenance of the UPS.

● Important Rules

- (1) Please follow the Kronos UPS operating instructions to ensure safe and proper operation.
- (2) When the UPS is being moved or operated, please ensure that the machine is standing vertically. Do not shake or tip over the machine. Avoid heavy impact.
- (3) Poor grounding will lead to unexpected current leakage. Please ensure that the AC power input is properly grounded (PE Ground) before making any connections.
- (4) Please make sure that the UPS is placed in an insulated environment before use and that there is no risk of electrocution hazard to any personnel.
- (5) Do not connect the neutral wire with the ground and make sure that the input voltage phasing and conductor sizing is correct.
- (6) Once the UPS has been switched on, if the UPS needs to be moved then it must be fully switched off and fully discharged. If the UPS is not discharged, the UPS will switch to battery power after grid power is disconnected and pose an electrocution hazard.
- (7) Do not place any objects, liquid containers, or coverings on the UPS. Any liquid spilled onto the UPS could potentially lead to internal damage or high risk of electrocution.
- (8) Make sure that the battery specifications match the UPS requirements before connecting any external batteries.
- (9) For 30k/40k models: The over current protection for the external battery circuit is to be provided by others.
- (10) For 30k/40k models: The maximum available fault current from the battery supply is 15 KA minimum. The dc voltage rating of the battery supply over current protection device must be installed near the battery supply must have a minimum rating of 250 VDC.
- (11) Follow the safety guidelines below before engaging in any testing that involves the battery.
 - a. Remove all metallic items such as rings, watches and jewelry before working on the batteries.
 - b. Always wear eye protection and use insulated tools.
 - c. Do not open or damage the batteries. The toxic liquid inside will harm the skin and eyes.
 - d. Keep batteries away from fire to prevent explosion.
- (12) A readily accessible disconnect device shall be incorporated external to the equipment.
- (13) For 10-20k models:
 - This UPS may be provided with maximum one extension battery packs
 - External DC Circuit disconnect Device shall be provided by other.
 - Before installing or servicing the equipment, identify and disconnect the UPS from the AC mains and load. The UPS contains internal batteries and may present a shock hazard even when disconnected from the AC input branch circuit (mains).
 - Any wiring, maintenance service and battery replacement, must be performed or supervised by personnel knowledgeable about batteries and the required precautions.
 - When replacing batteries, replace with the same type and number of batteries or battery packs.
 - CAUTION: Do not dispose of batteries by burning them. The batteries may explode.

- CAUTION: Do not open or mutilate batteries. Released electrolyte is harmful to the skin and eyes, and may be toxic.
- CAUTION: A battery can present a risk of electrical shock and high short-circuit current through conductive materials could cause severe burns. The following precautions should be observed when working on batteries:
Before installing or replacing the batteries, remove jewelry such as wristwatches and rings, or other metal objects.
- When working on batteries should wear rubber gloves and boots. Also, must use tools with insulated handles, and do not lay tools or metal parts on top of batteries. Remove battery grounds during installation and maintenance to reduce likelihood of shock. Remove the connection from ground if any part of the battery is determined to be grounded.

● **Symbols**

Always follow the instructions and warnings on the UPS.

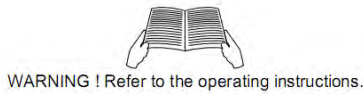

WARNING ! Refer to the operating instructions.



WARNING ! High voltage inside.



Ground

NOTE

NOTE: This equipment has been tested and found to comply with the limits for a Class A digital device, pursuant to part 15 of the FCC Rules. These limits are designed to provide reasonable protection against harmful interference when the equipment is operated in a commercial environment. This equipment generates, uses, and can radiate radio frequency energy and, if not installed and used in accordance with the instruction manual, may cause harmful interference to radio communications. Operation of this equipment in a residential area is likely to cause harmful interference in which case the user will be required to correct the interference at his own expense.

- **WARNING**

WARNING: This is a category C2 UPS product. In a residential environment, this product may cause radio interference, in which case the user may be required to take additional measures.

1. Function Description

1.1 UPS Block Diagram

The system block diagram is shown below.

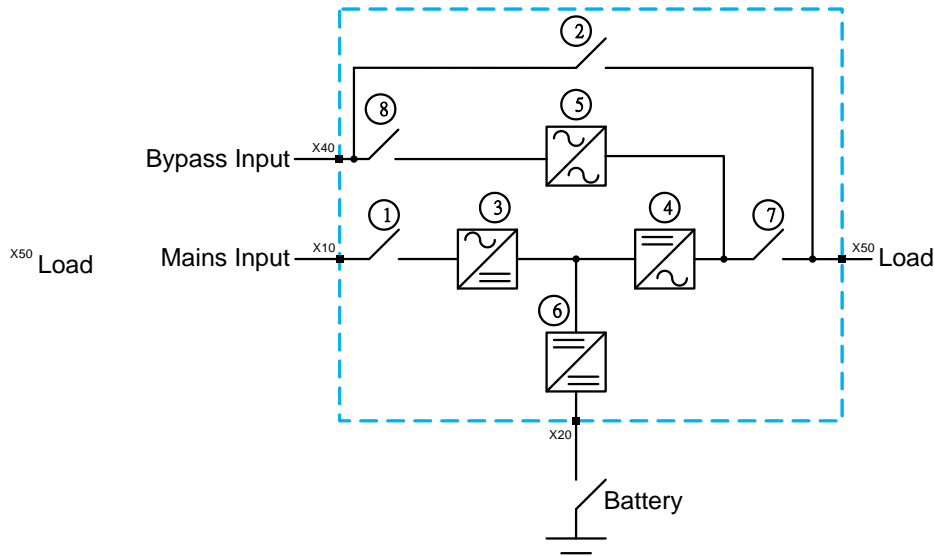

- | | | | |
|---|-----------------------|---|-----------------|
| 1 | Input Breaker/Switch | 5 | Static Switch |
| 2 | Manual Bypass Breaker | 6 | Charger/Booster |
| 3 | Rectifier | 7 | Output Breaker |
| 4 | Inverter | 8 | Bypass Breaker |

1.2 UPS Front View
■ **10kVA Front View**

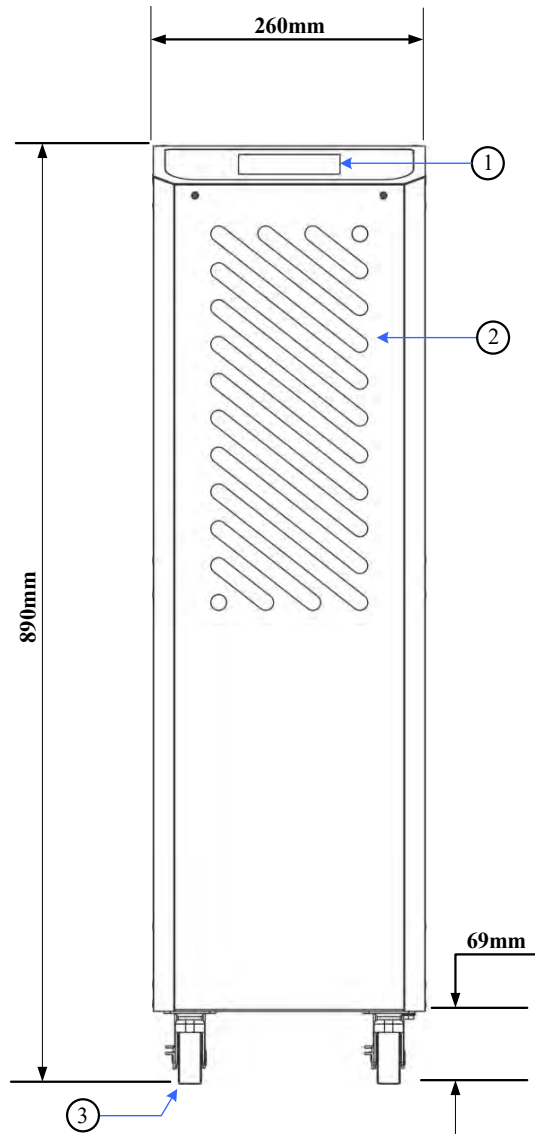

- 1 Control Panel with Color LCD Touch Screen
- 2 Ventilation Grille
- 3 Wheels for Positioning

■ 15-20kVA Front View

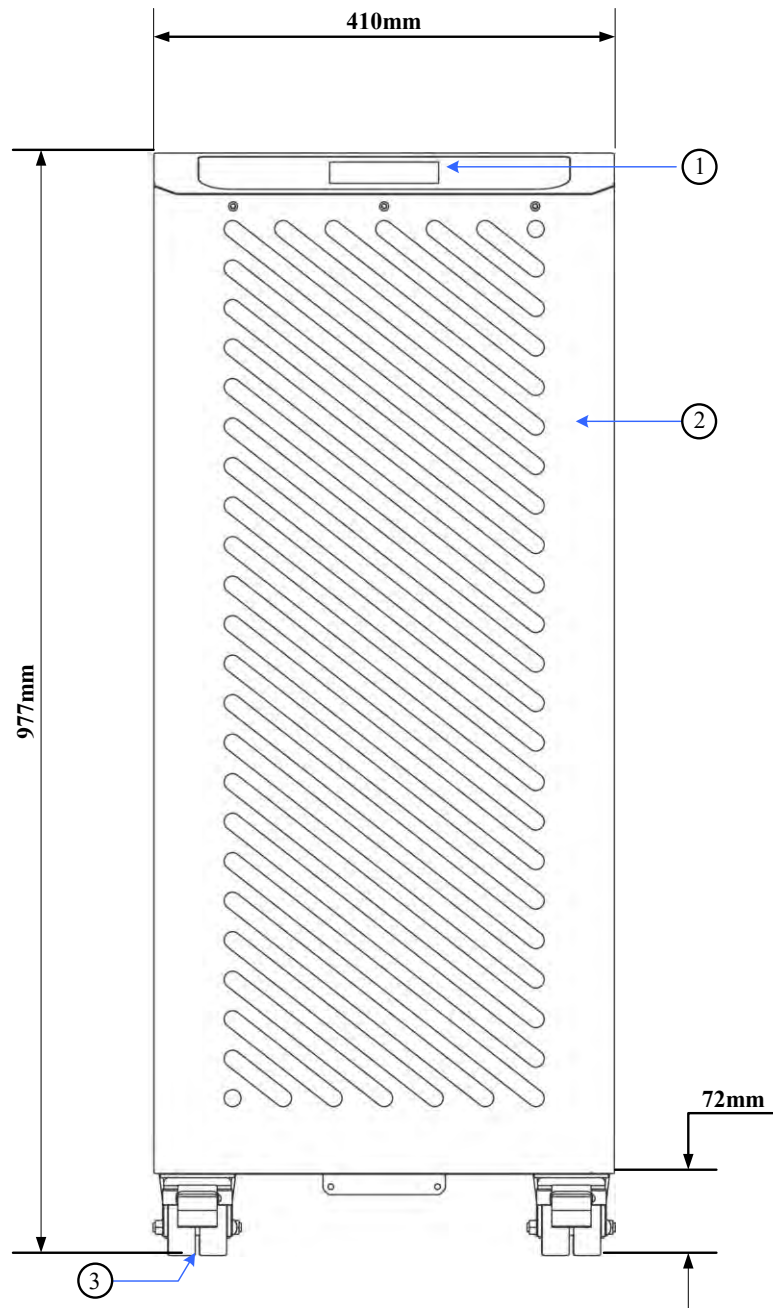

1 Control Panel with Color LCD Touch Screen

3 Wheels for Positioning

2 Ventilation Grille

■ 30-40kVA Front View

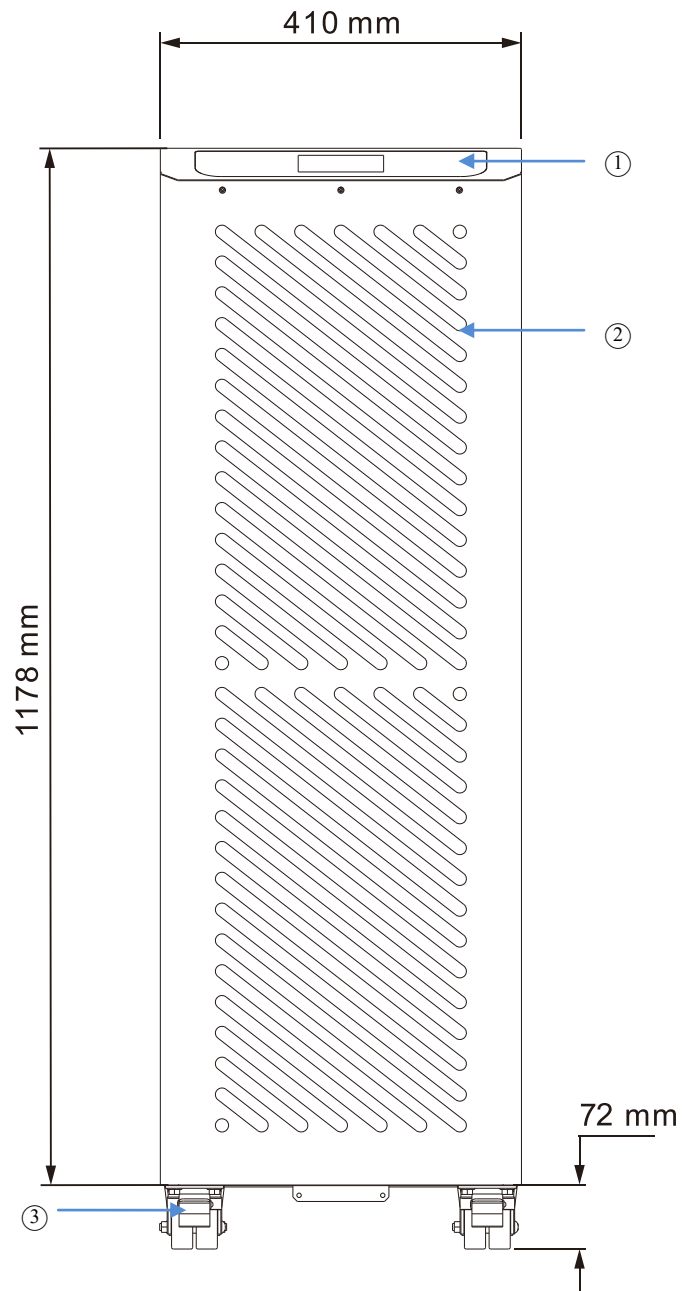

1 Control Panel with Color LCD Touch Screen

3 Wheels for Positioning

2 Ventilation Grille

■ 10kVA Right Side View

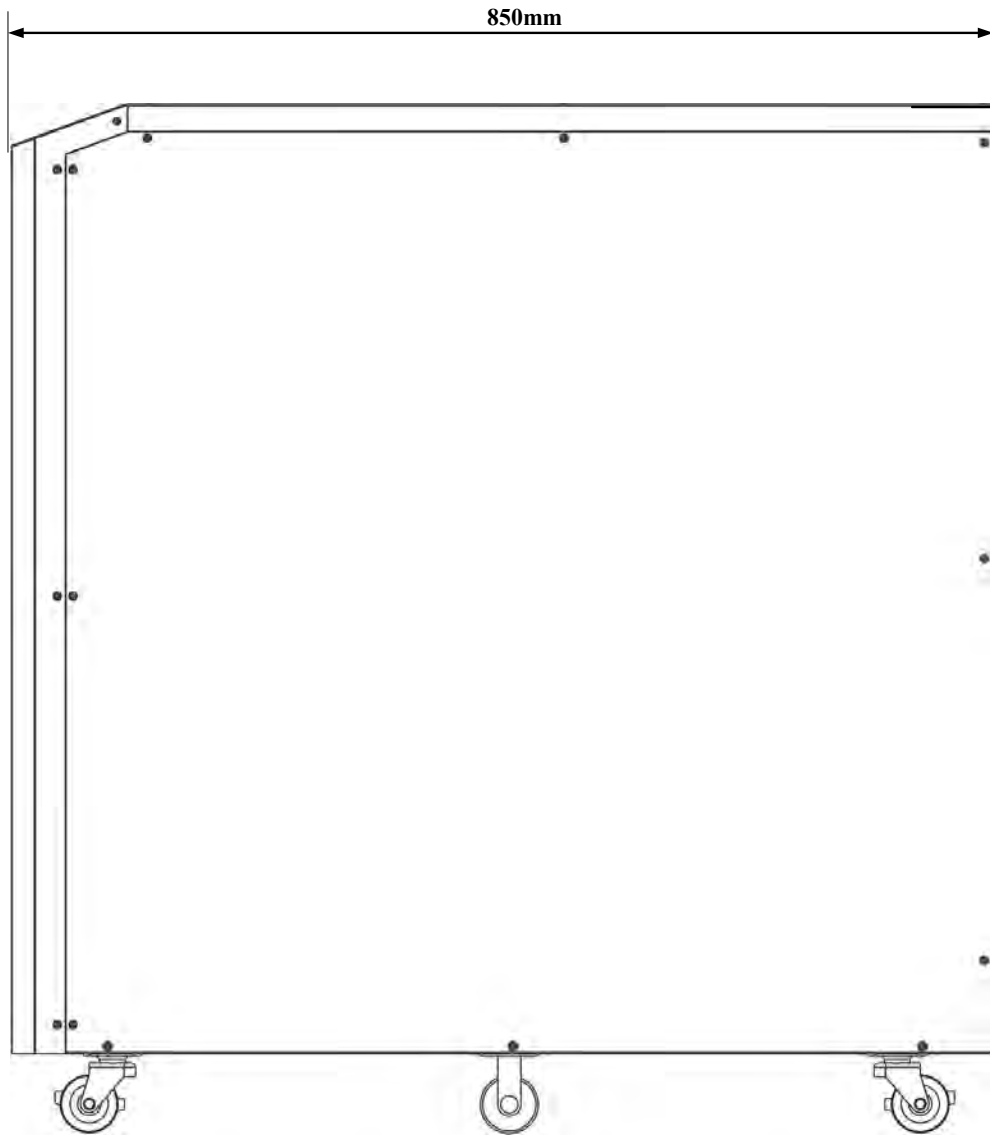

■ 15-20kVA Right Side View

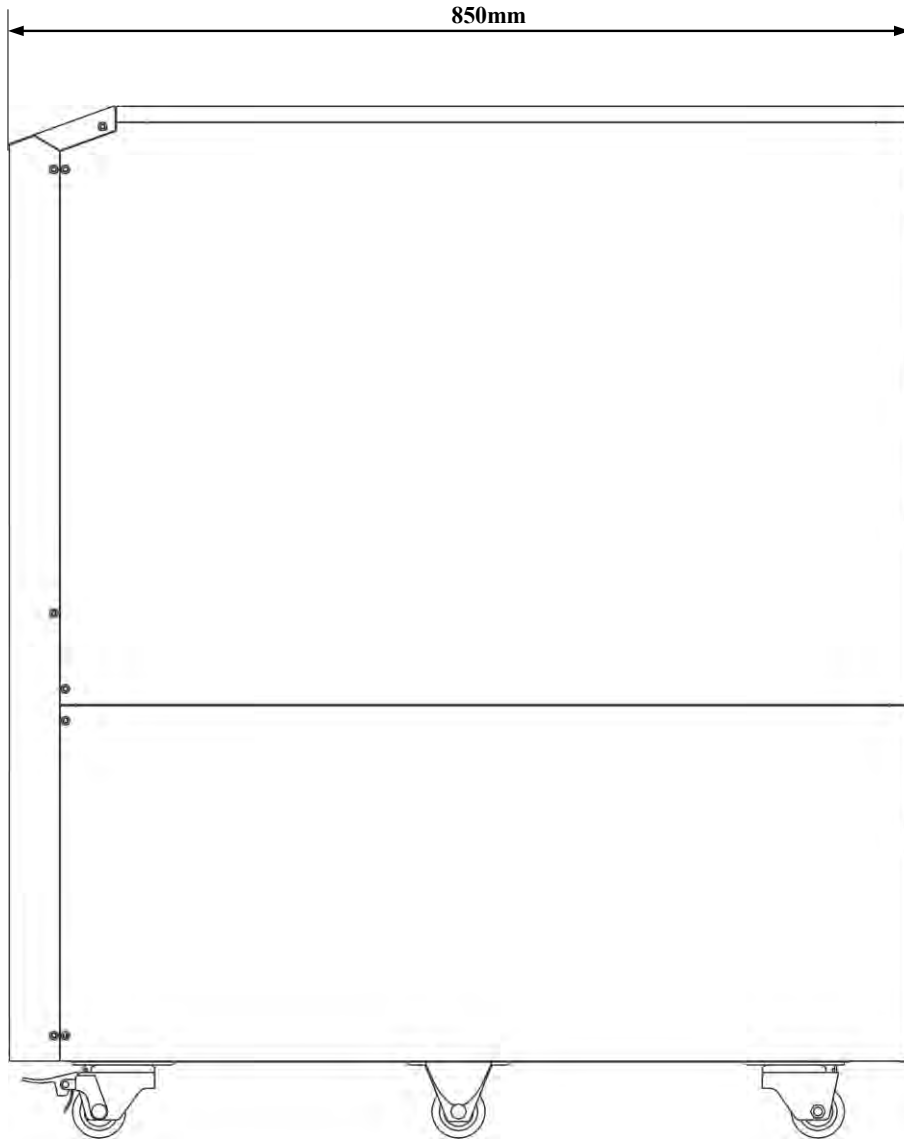

■ 30-40kVA Right Side View

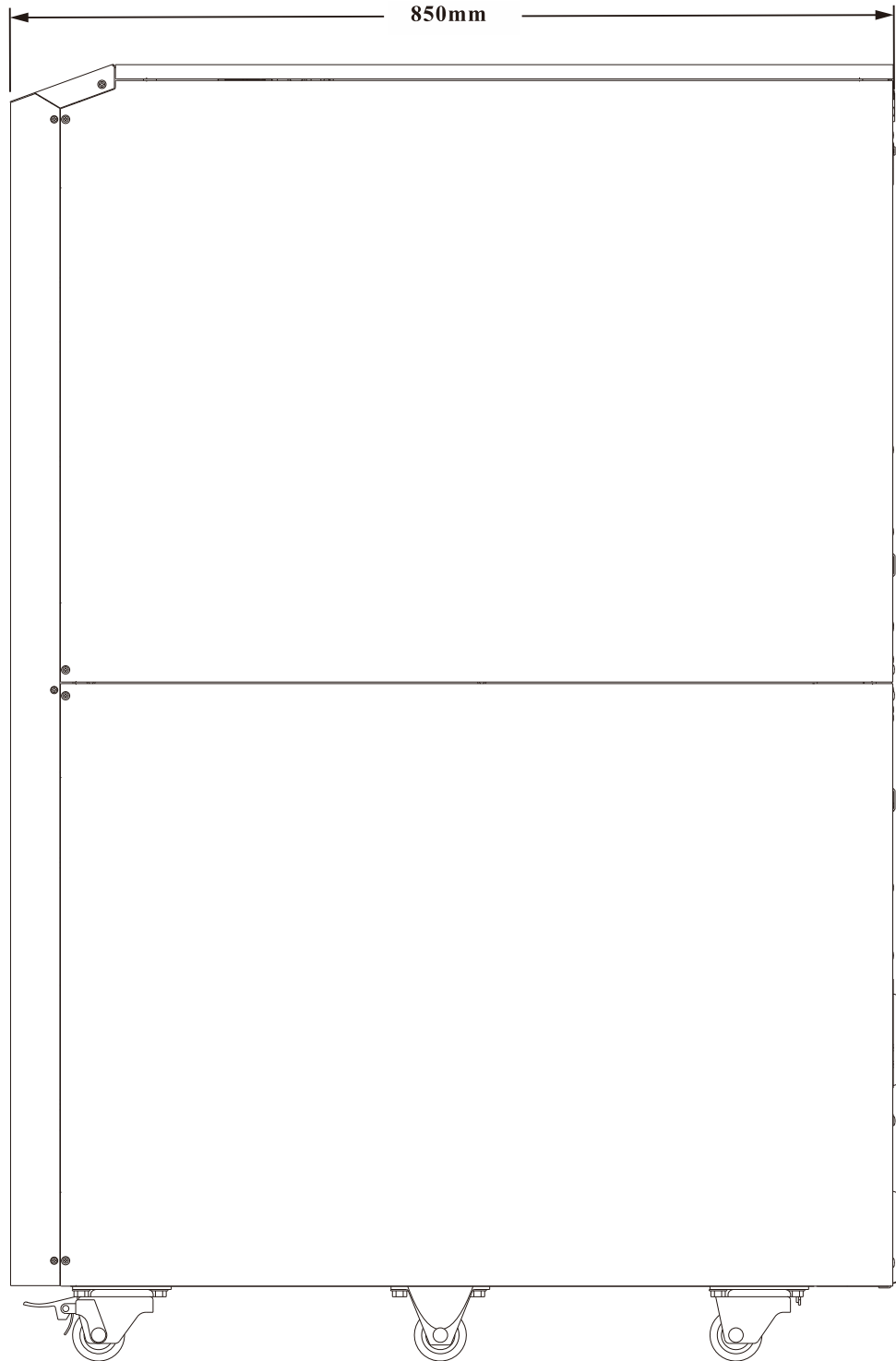

■ 10kVA Rear View

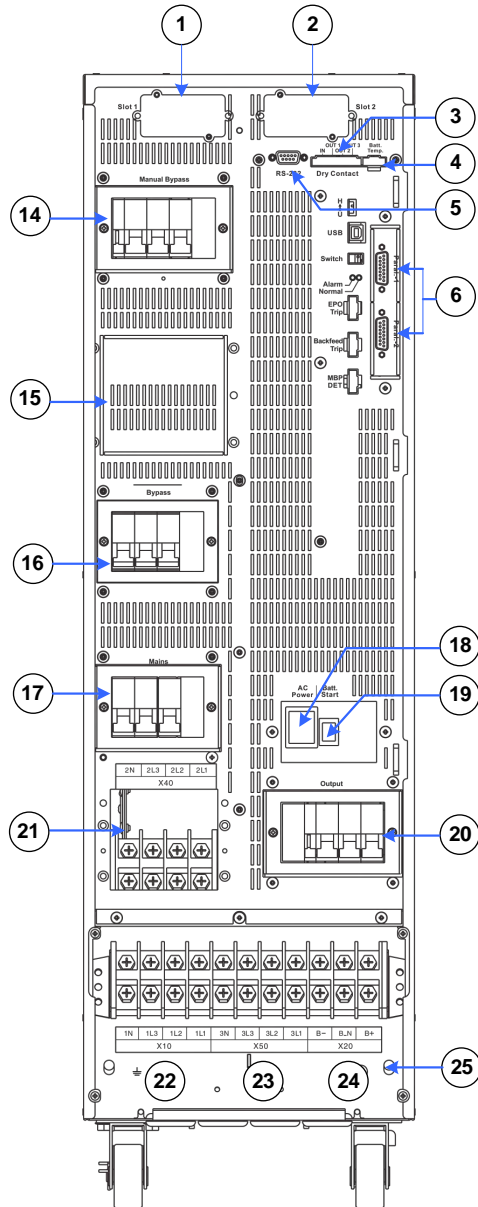

- 14. Manual Bypass Breaker
- 15. Bypass Fuses
- 16. Bypass Input Breaker
- 17. Mains Input Breaker
- 18.AC Power
- 19. Batt. Start

- 1. Communication Slot 1
- 2. Communication Slot2
- 3. Dry Contacts
- 4. External Battery Temperature Connector
- 5. RS-232 Port for Setting Software
- 6. Parallel Communication Ports(Optional)

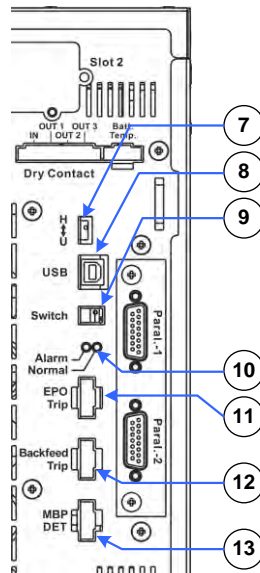

- 7. Communication Selector for Service Only
- 8. USB Port for Service Only
- 9. Terminal Resistor Setting Switch for Parallel Communication
- 10. Status LED Indictors
- 11. EPO
- 12. Backfeed Protection
- 13. MBP Detector

Please find the detail descriptions of above items on section 2-6.

- 20. Output Breaker
- 21. X40: Bypass Input Connections Terminal(2N, 2L3, 2L2, 2L1)
- 22. X10: Mains Input Connections Terminal(1N, 1L3, 1L2, 1L1)
- 23. X50: Output Connection Terminals (3N, 3L3, 3L2, 3L1)
- 24. X20: External Battery Connection Terminals(B-, B_,B+)
- 25. Ground Connection

■ **15-20kVA Rear View**

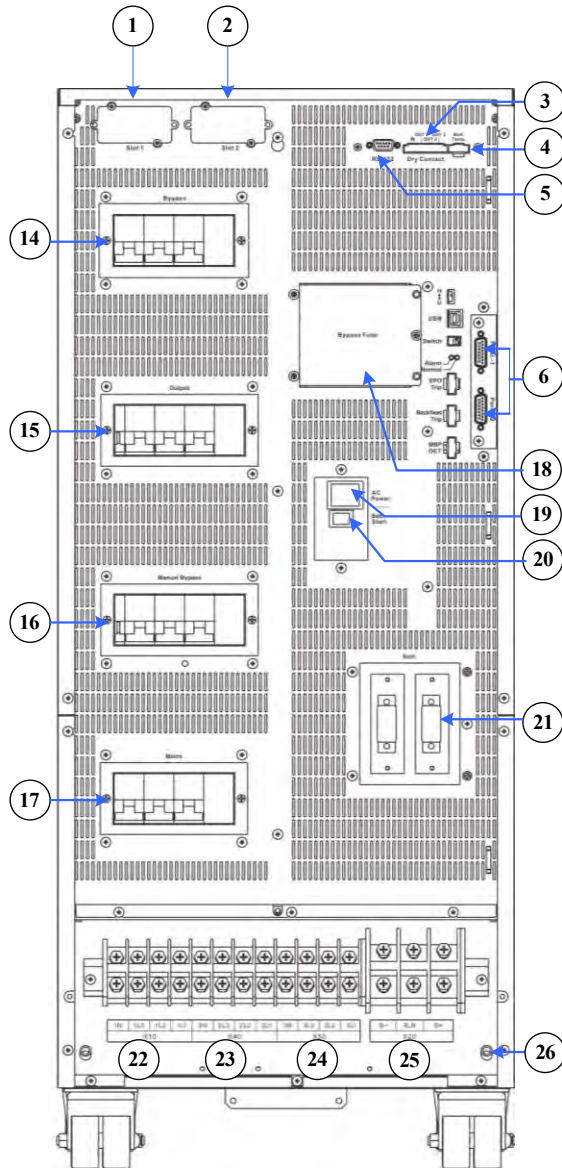

- 1. Communication Slot 1
- 2. Communication Slot2
- 3. Dry Contacts
- 4. External Battery Temperature Connector
- 5. RS-232 Port for Setting Software
- 6. Parallel Communication Ports(Optional)

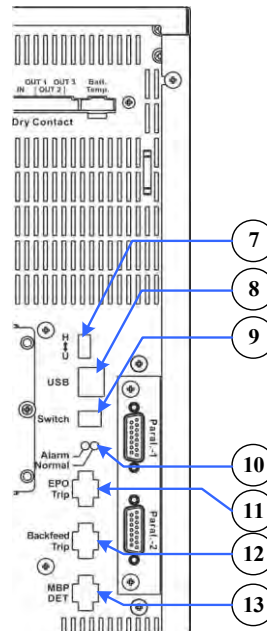

- 7. Communication Selector for Service Only
- 8. USB Port for Service Only
- 9. Terminal Resistor Setting Switch for Parallel Communication
- 10. Status LED Indicators
- 11. EPO
- 12. Backfeed Protection
- 13. MBP Detector

Please find the detail descriptions of above items on section 2-6.

- 14. Bypass Input Breaker
- 15. Output Breaker
- 16. Manual Bypass Breaker
- 17. Mains Input Breaker
- 18. Bypass Fuses
- 19. AC Power
- 20. Batt. Start
- 21. Batt. Fuses
- 22. X10: Mains Input Connections Terminal(1N, 1L3, 1L2, 1L1)
- 23. X40: Bypass Input Connections Terminal(2N, 2L3, 2L2, 2L1)
- 24. X50: Output Connection Terminals (3N, 3L3, 3L2, 3L1)
- 25. X20: External Battery Connection Terminals(B-, B_N,B+)
- 26. Ground Connection

■ 30-40kVA Rear View

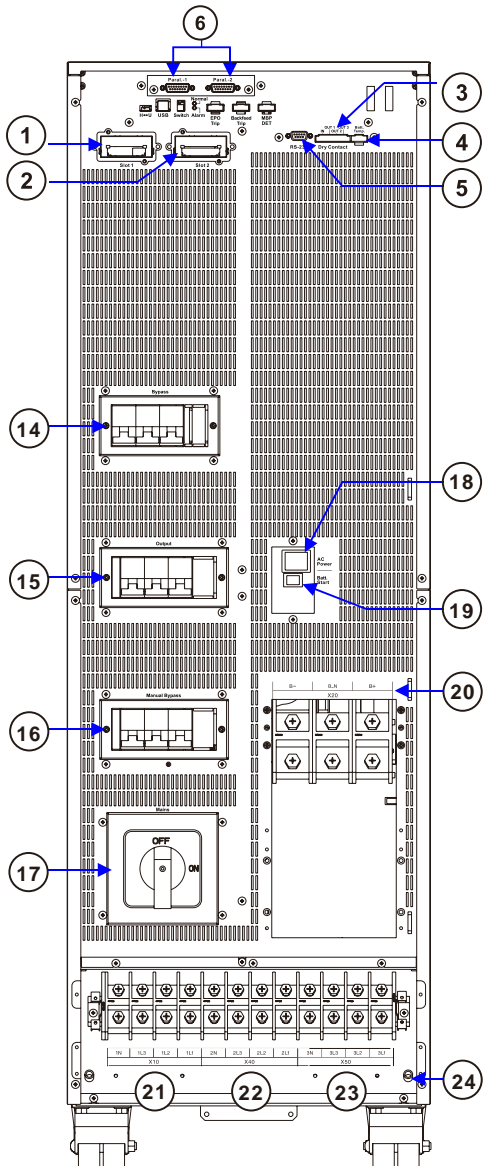

1. Communication Slot 1
2. Communication Slot2
3. Dry Contacts
4. External Battery Temperature Connector
5. RS-232 Port for Setting Software
6. Parallel Communication Ports(Optional)

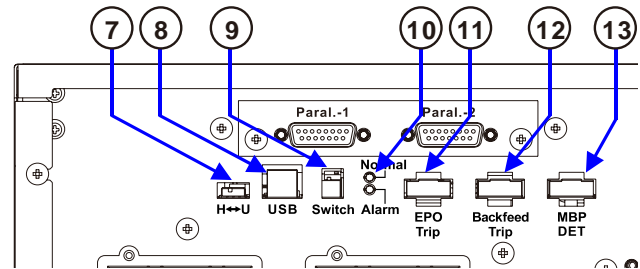

7. Communication Selector for Service Only
8. USB Port for Service Only
9. Terminal Resistor Setting Switch for Parallel Communication
10. Status LED Indicators
11. EPO
12. Backfeed Protection
13. MBP Detector

Please find the detail descriptions of above items on section 2-6.

14. Bypass Input Breaker

15. Output Breaker

16. Manual Bypass Breaker

17. Mains Input Switch

18. AC Power

19. Batt. Start

20. X20: External Battery Connection Terminals(B-, B_N,B+)

21. X10: Mains Input Connections Terminal(1N, 1L3, 1L2, 1L1)

22. X40: Bypass Input Connections Terminal(2N, 2L3, 2L2, 2L1)

23. X50: Output Connection Terminals (3N, 3L3, 3L2, 3L1)

24. Ground Connection

■ 10kVA Internal Right View

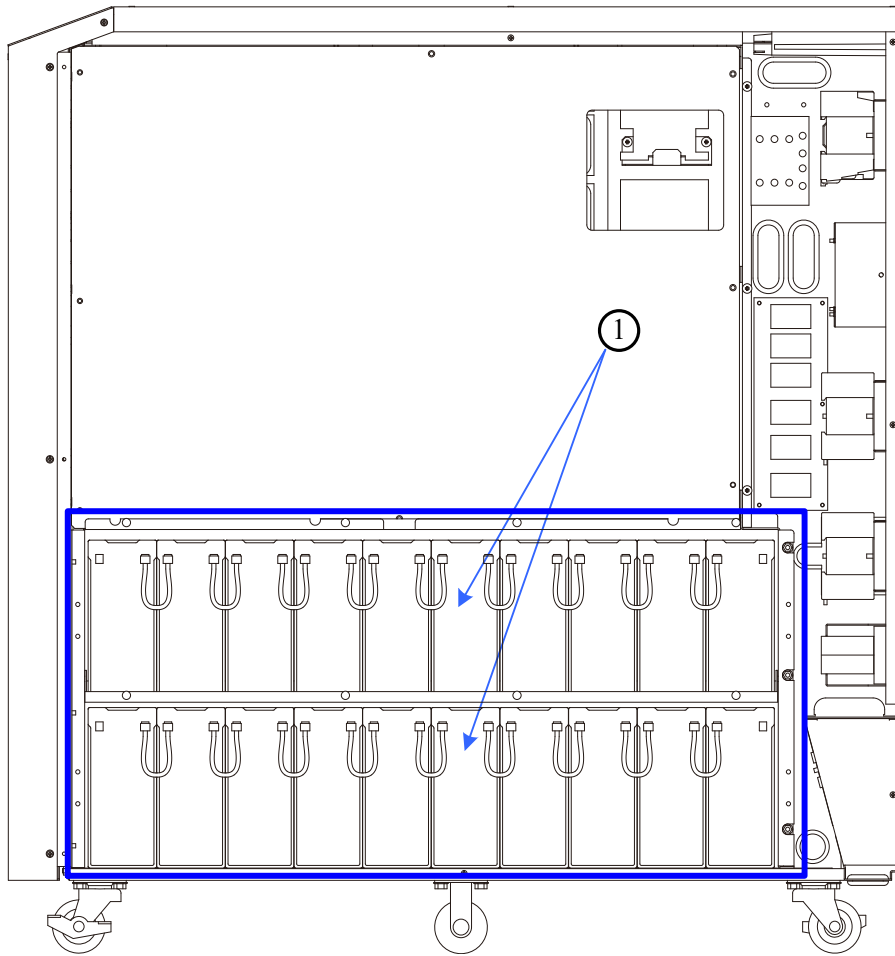

1. Battery Tray

■ 15-20kVA Internal Right View

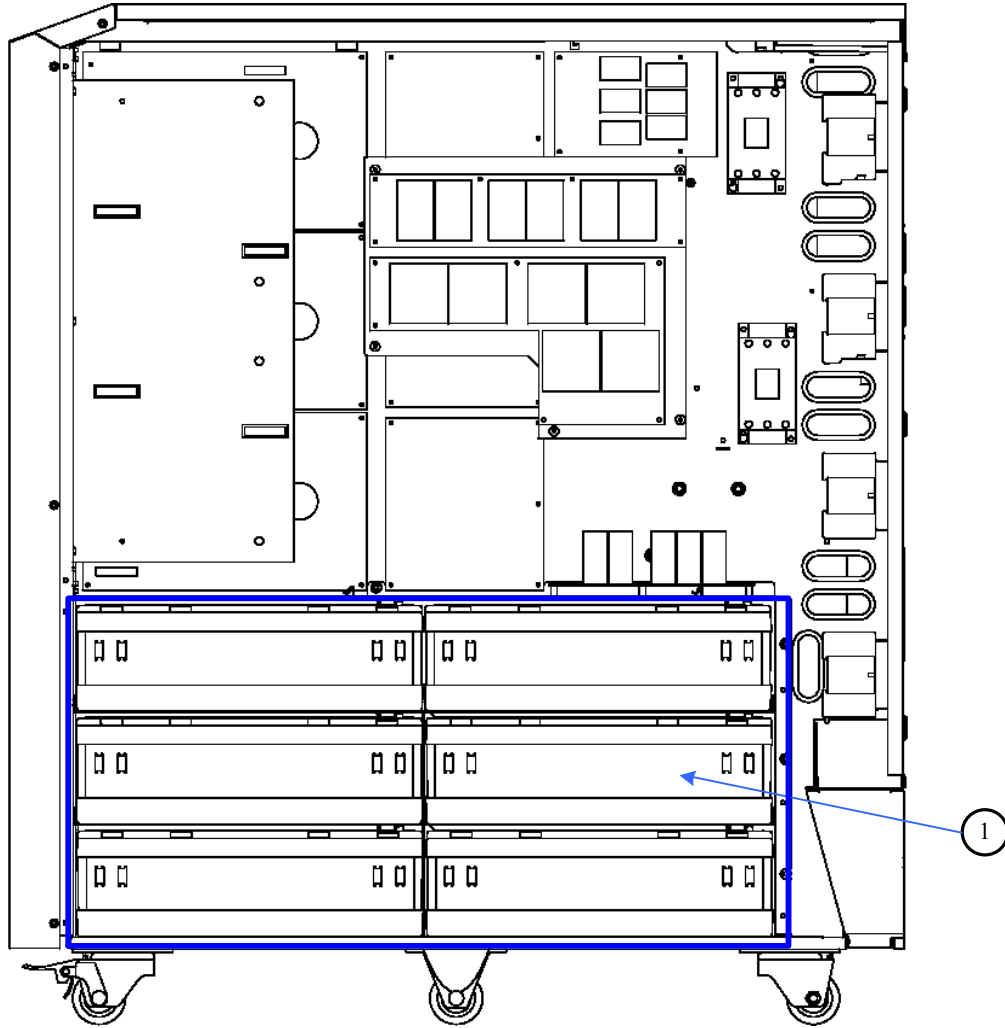

1. Battery Tray

■ 10kVA Internal Top View

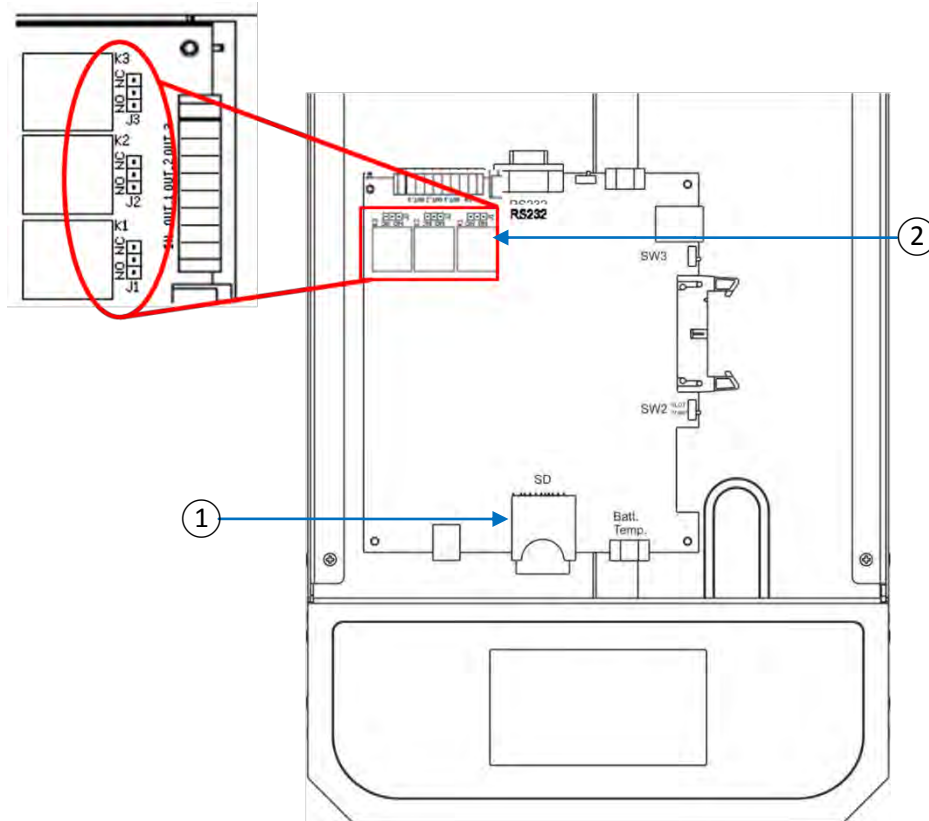

1. SD Card Slot
2. Jumpers (J1~J3) for each output contact

The detailed descriptions of the above items are located in section 2-6.

■ 15-20kVA Internal Top View

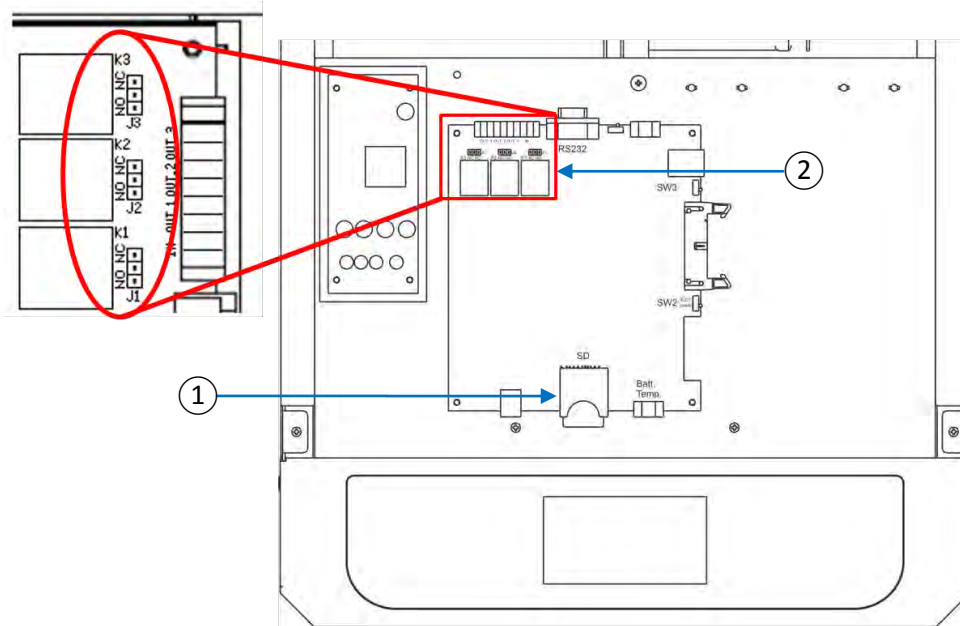

1. SD Card Slot
2. Jumpers (J1~J3) for each output contact

The detailed descriptions of the above items are located in section 2-6.

■ 30-40kVA Internal Top View

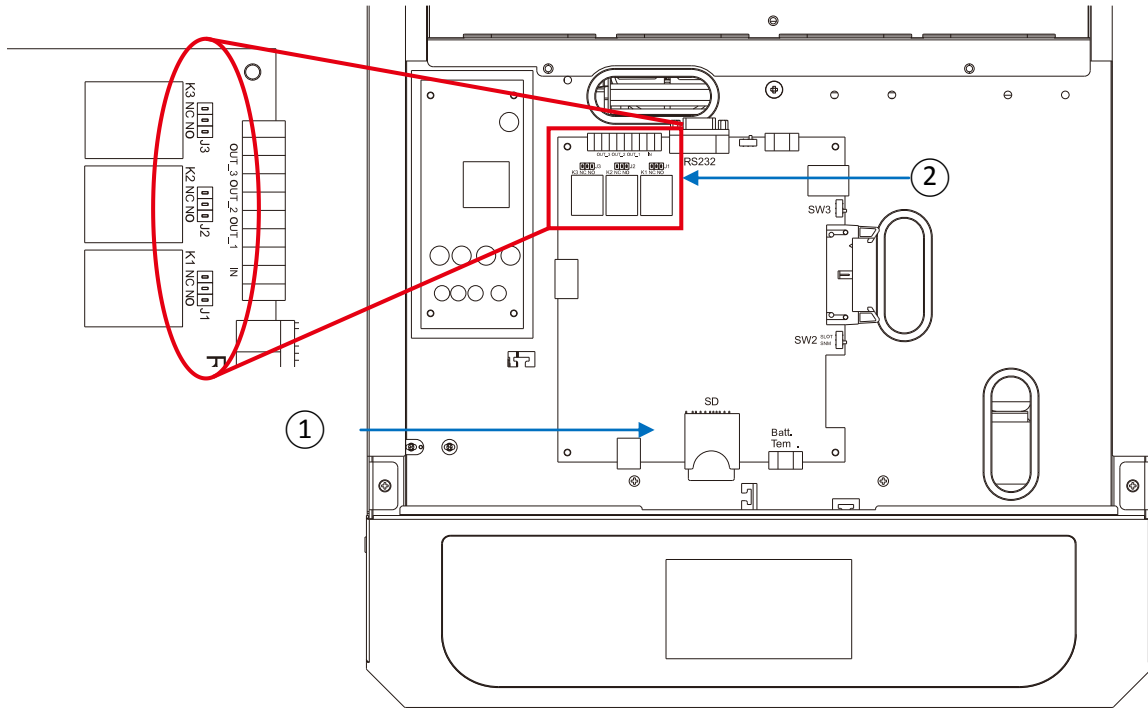

1. SD Card Slot

2. Jumpers (J1~J3) for each output contact

Please find the detail descriptions of above items on section 2-6.

2. Installation and Wiring

2.1 Storage and Installation Environment

■ Storage Environment

- Temperature-20°C~70°C
- Relative Humidity \leq 95%

■ Installation Environment

A proper installation environment not only ensures the effective operation of the UPS but it also reduces the chance of failure and extends service life. Take the following recommendations into account when selecting a suitable environment. This will also minimize any potential accidents.

- This product must be use in a CONTROLLED ENVIRONMENT.
- Temperature 0°C~40°C (20°C~25°C is recommended for extend batteries life time).
- Relative Humidity \leq 95% (without condensation)
- Altitude 1000m at normal power. Over 1000m above sea level, the maximum output current must be derated by 1% every additional 100m.
- This product must not be used in an environment with sparks, smoke or gas to prevent arcing, injury and fire hazards.
- Avoid using dusty materials, volatile gases, or corrosive substances with a high salt-content in the environment where the UPS is installed.
- The installation location of the UPS must be well-ventilated. During charging, the chemical reaction of the battery generates small amounts of gases. A crack in the any of the batteries may pose an environmental hazard.
- Do not place in a location near a heat source as this will shorten the battery life.
- Do not place outdoors and avoid direct exposure to sunlight.
- Always ensure that the environment where the UPS is located is free from animals that may damage the wiring, such as rats and domestic pets.
- Always ensure that the floor is designed enough to support the UPS and battery. The must meet the minimum requirements for floor weighting to prevent failure and injury.
- We recommend placing a fire extinguisher near the UPS in case of an emergency.

2.2 Unpacking, Removing and Securing UPS

This section describes the unpacking and removing processes with the wheels installed.

- Remove the packing materials and cut straps. Remove and slide up the cardboard box.

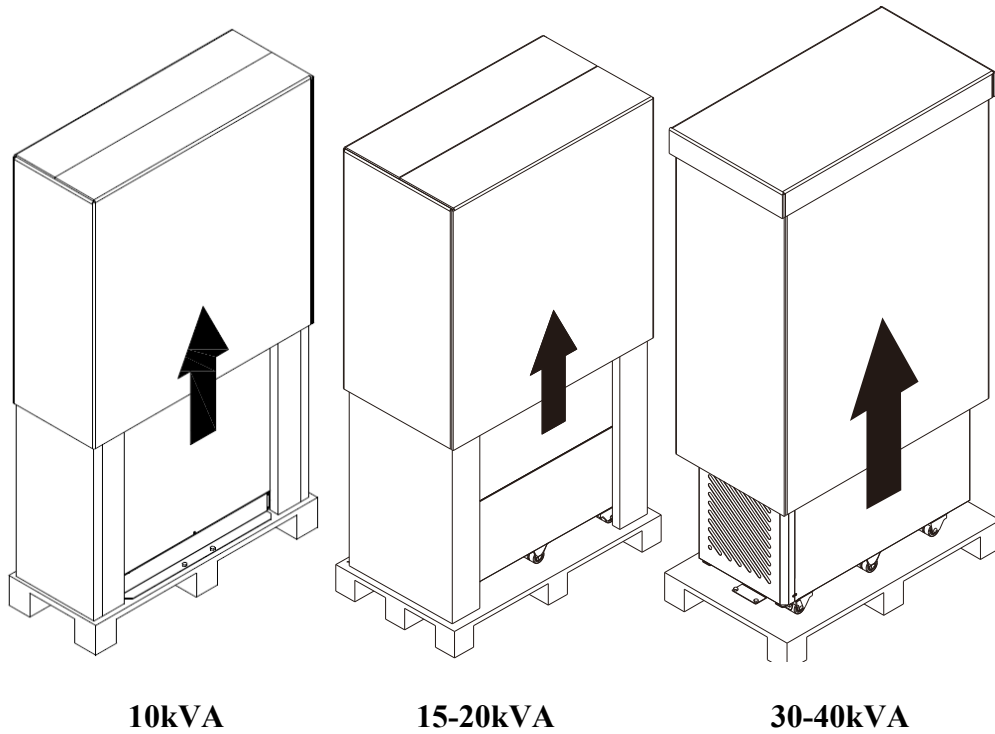

- Unscrew the fasteners on the ramp kits located on the right and left side of 10kVA, as well as at the front side of 15-40kVA.

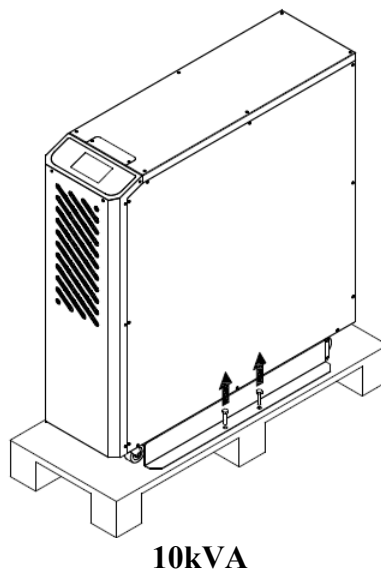

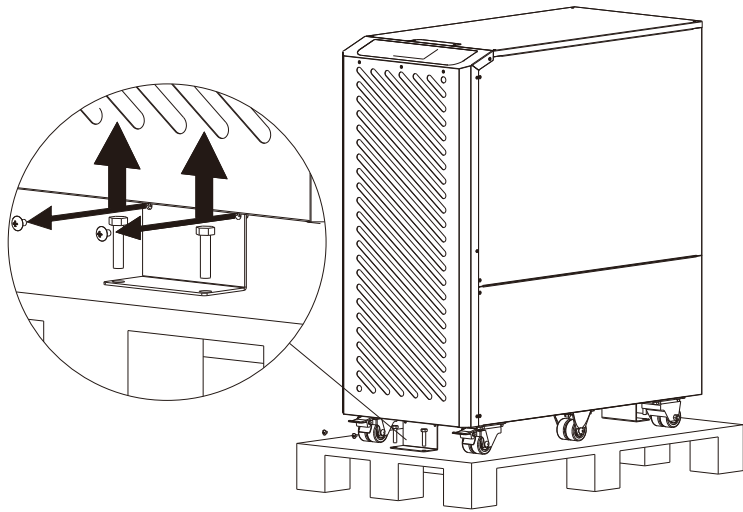

15-20kVA

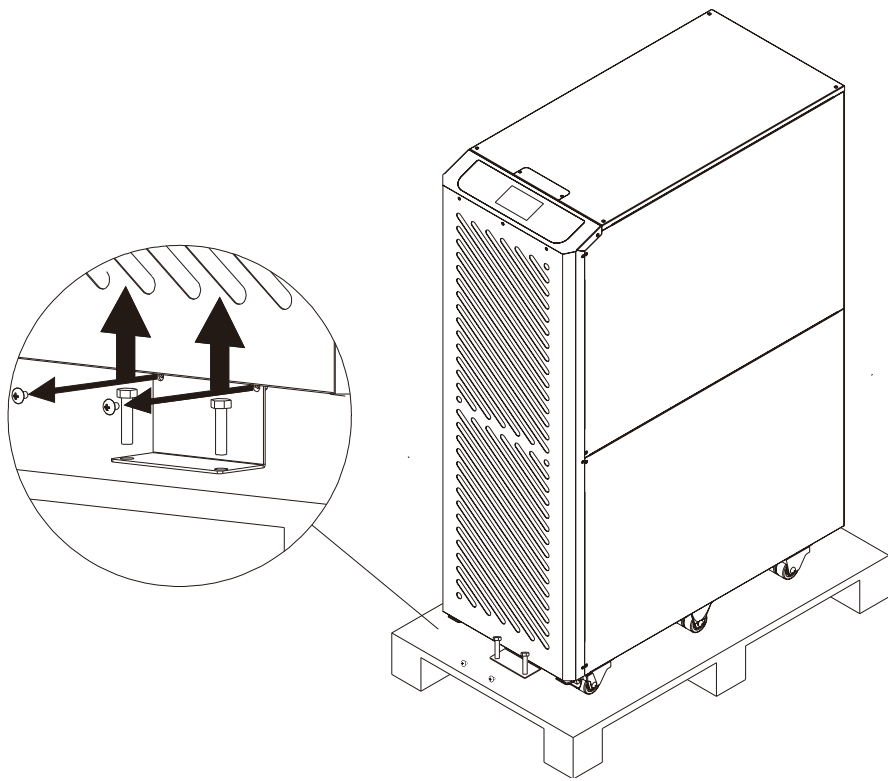

30-40kVA

- Install 2 fasteners on the rail kits on the pallet edge by fastening 4 screws in the pallet.

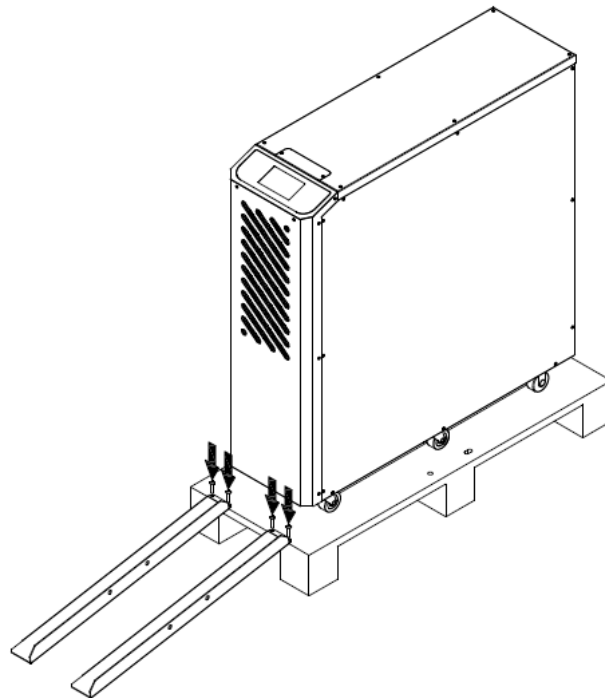

10kVA

- Remove the UPS from the pallet by using the rails to slide the UPS forward onto a flat surface. See the next figure when using a Fork Lift to remove the UPS from the pallet.

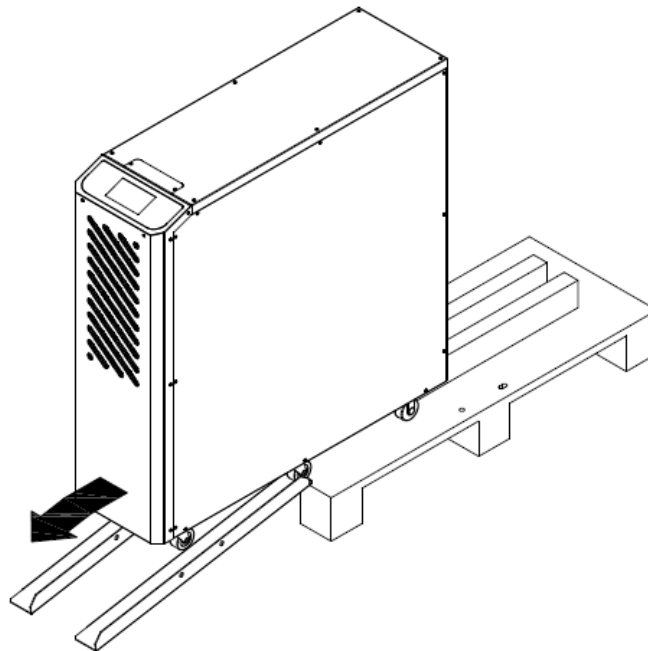

10kVA

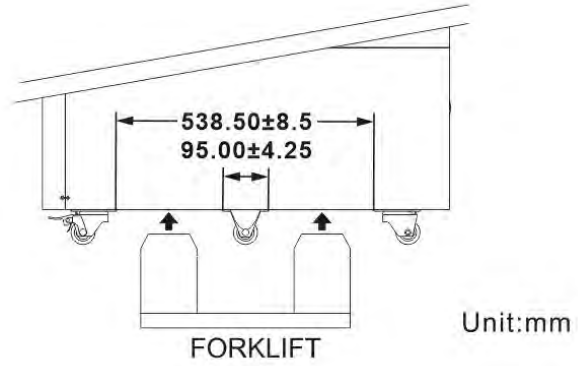
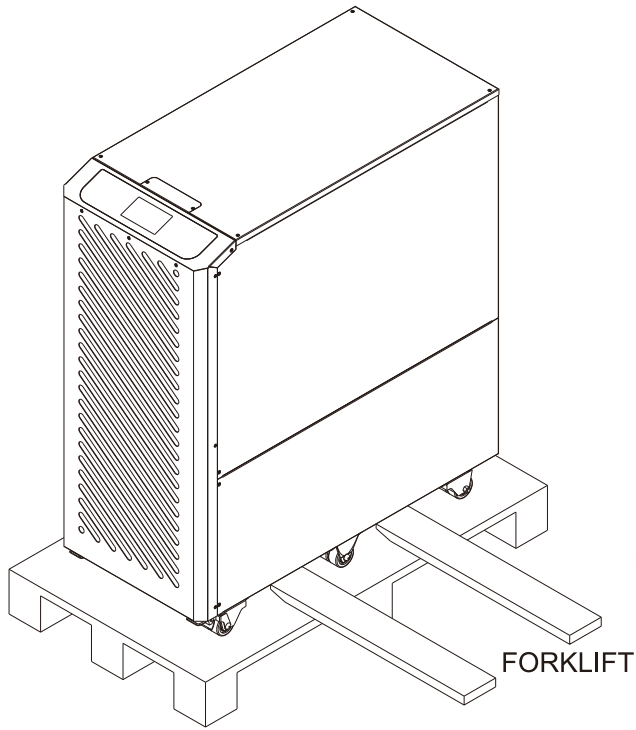

15-20kVA

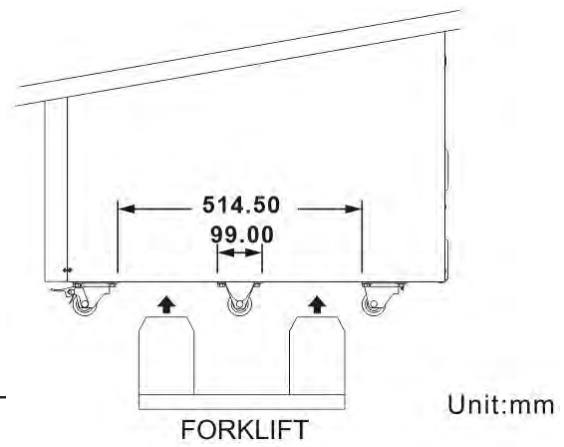
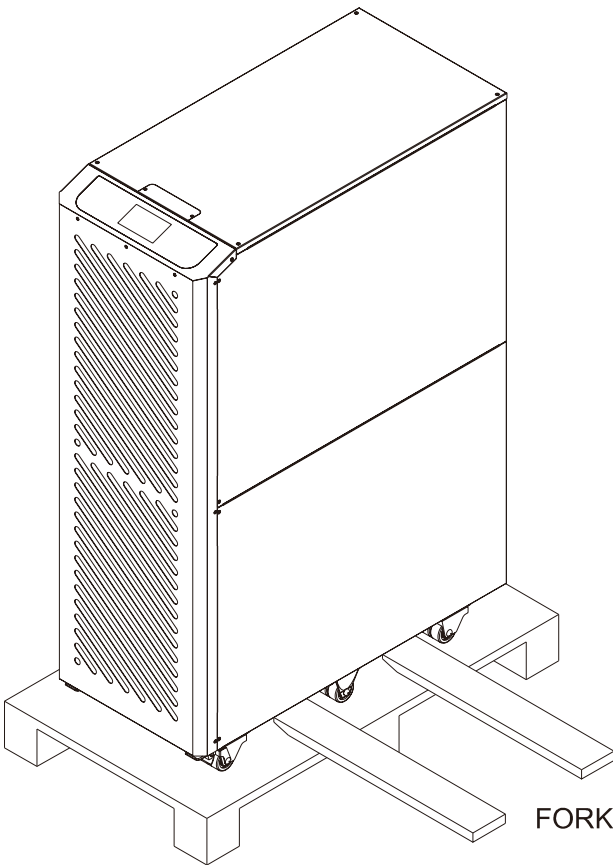

30-40kVA

- Raise the wheel-brakes to remove the UPS.

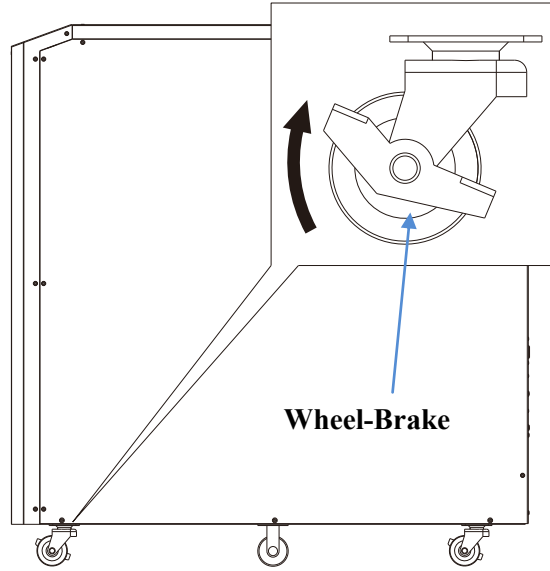

10kVA

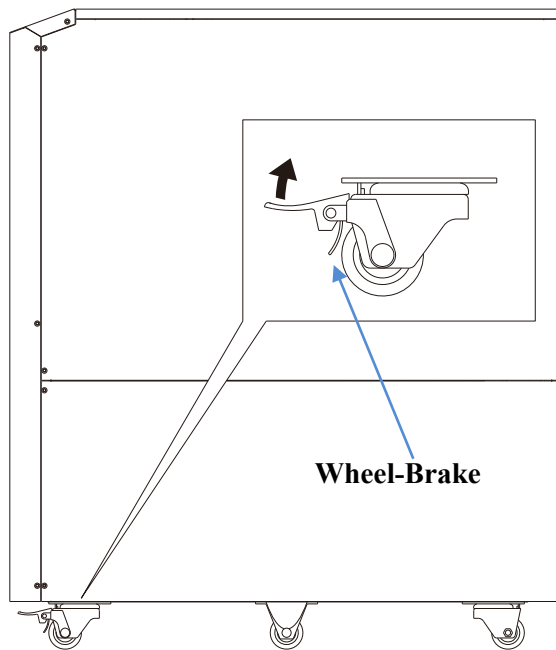

15-20kVA

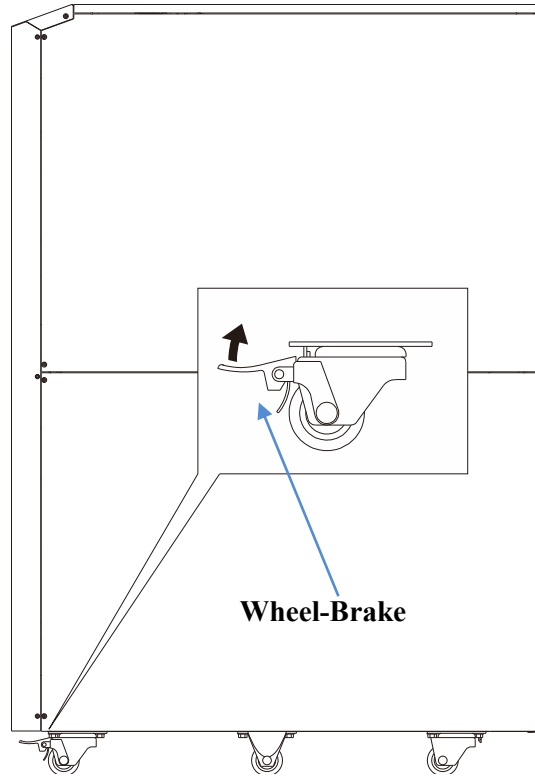

30-40kVA

- Block the wheel-brakes to secure the UPS.

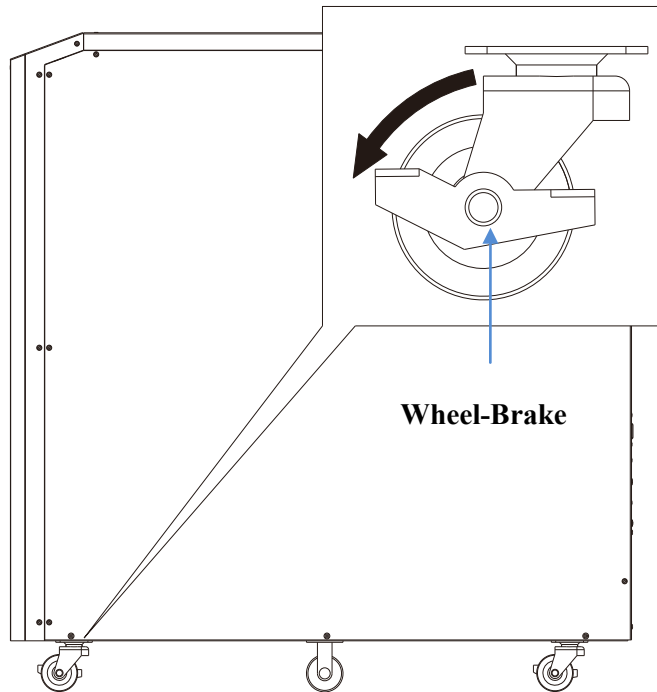

10kVA

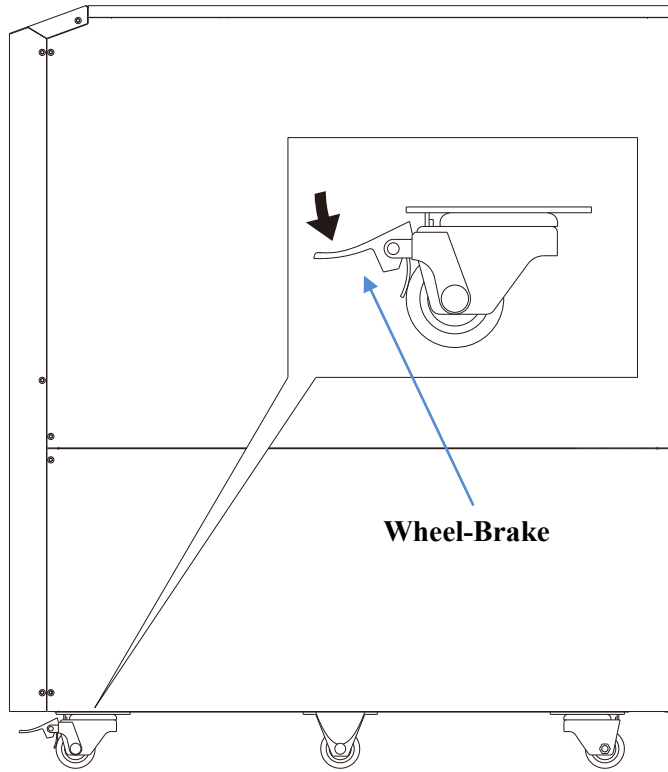

15-20kVA

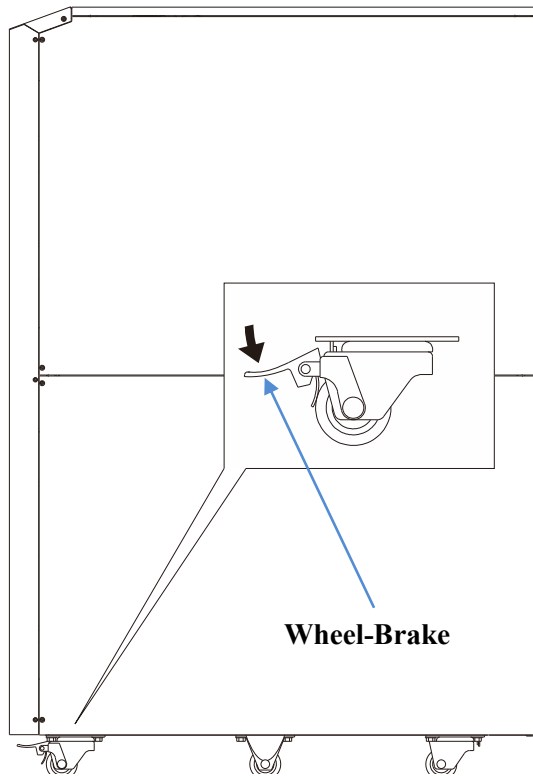

30-40kVA

- Follow this step to secure the UPS.

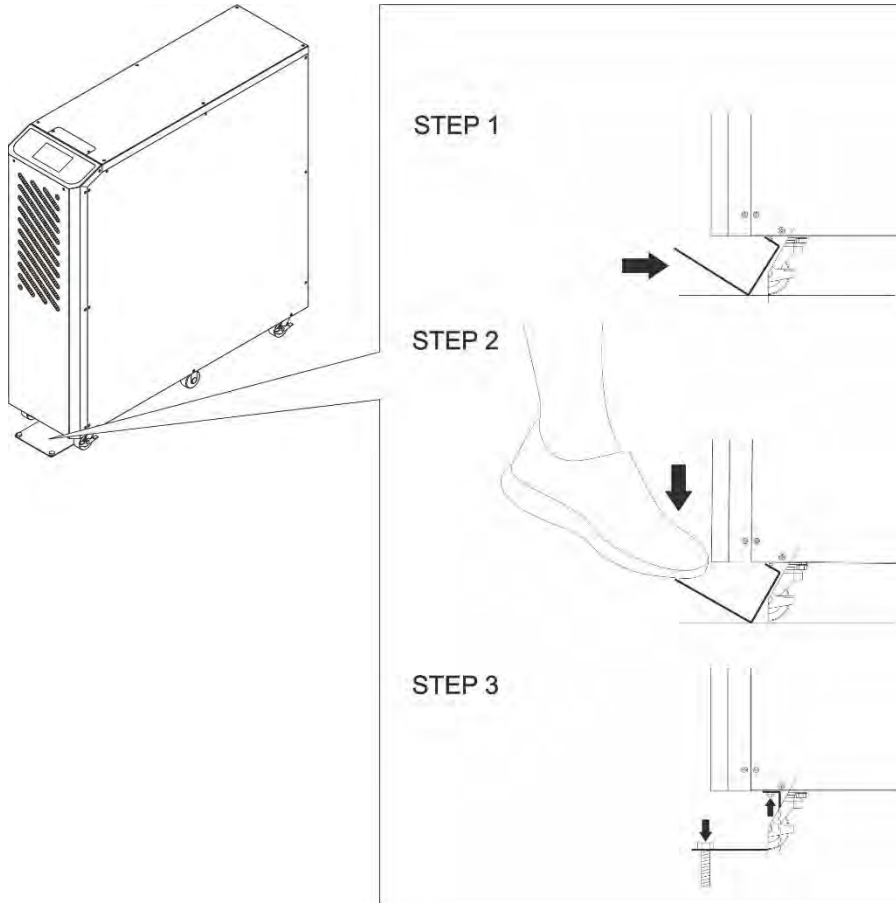

10kVA

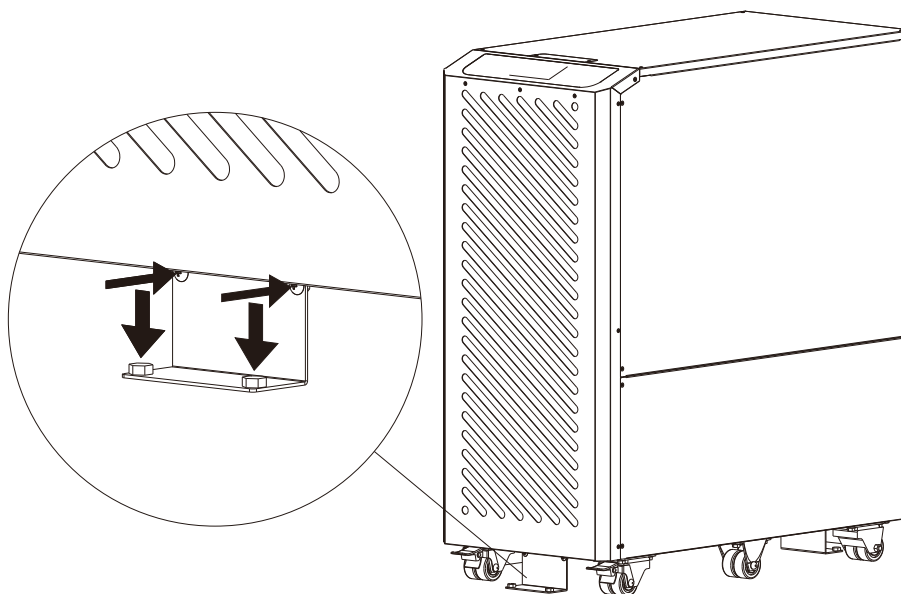

15-20kVA

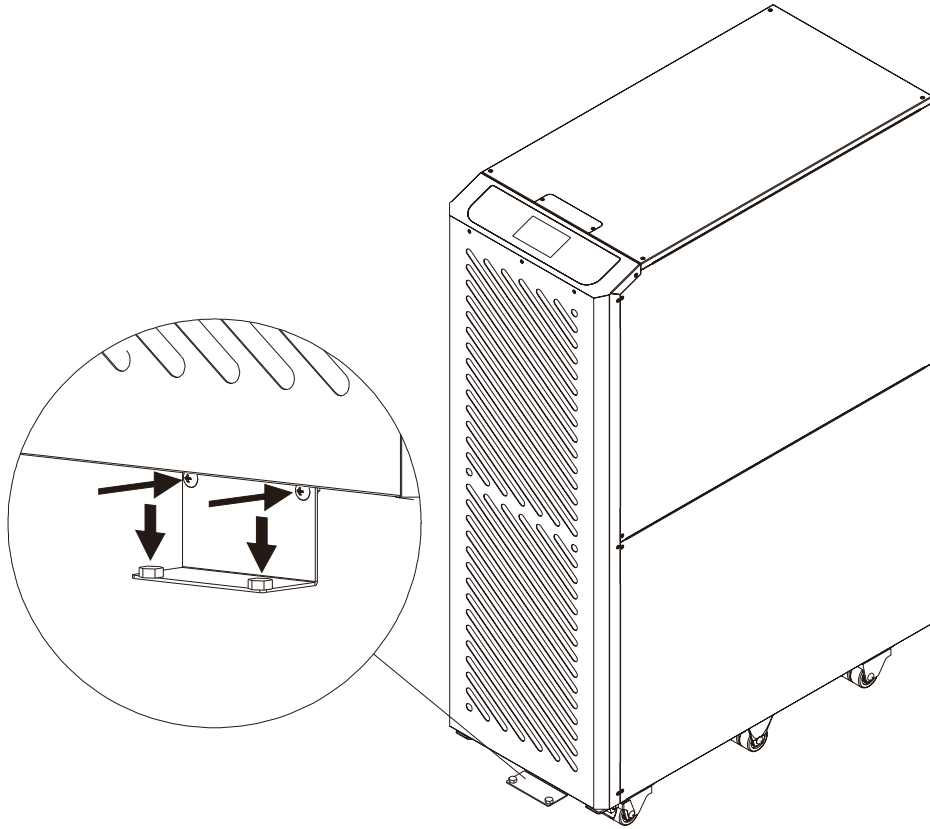

30-40kVA

2.3 General Requirements for Ventilation and Maintenance

During the installation ensure that the following conditions are followed.

- Keep at least 1000mm of clearance to the front of the UPS for air flow and future maintenance purposes.
- Keep at least 300mm of clearance from the rear of the UPS for air-flow space.
- Keep at least 300mm of clearance to the top of UPS for maintenance operations.

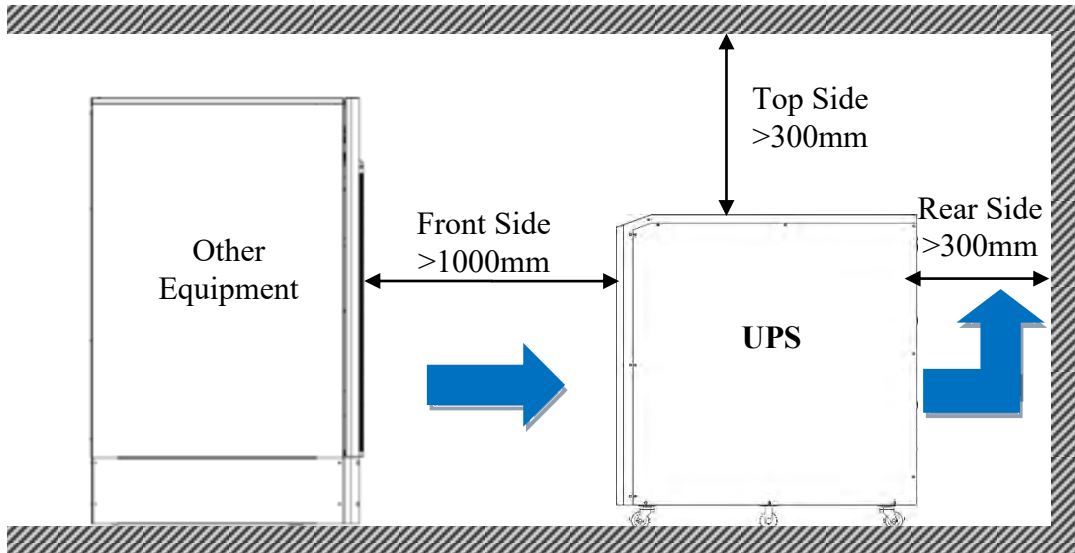

2.4 Power Cables Connections

■ Power Connection Positions

The drawing below shows the positions of the power terminals.

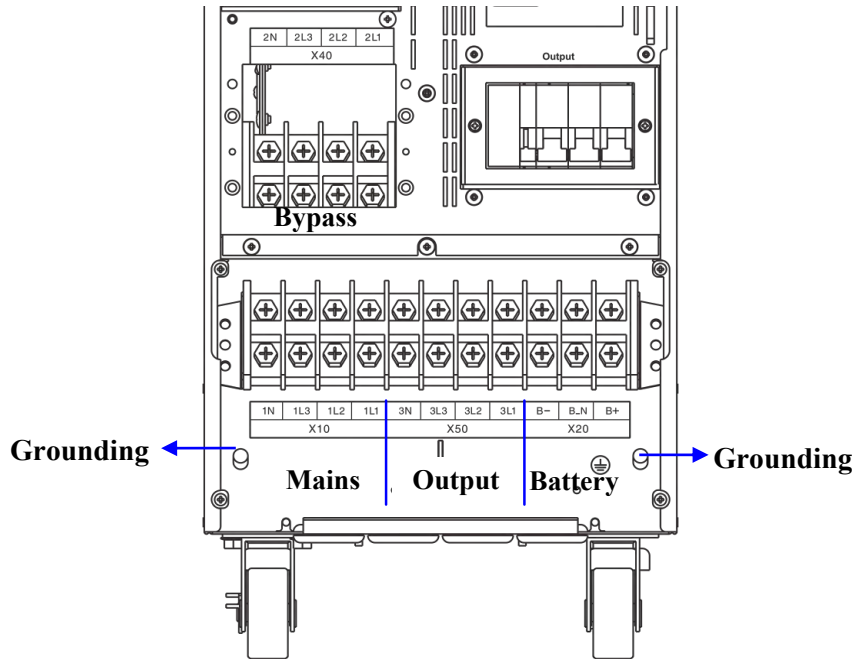

10kVA Power Terminal Positions

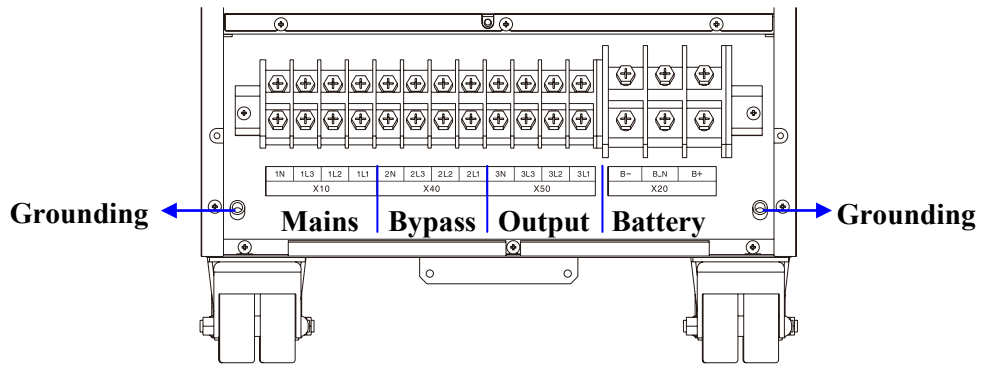

15-20kVA Power Terminal Positions

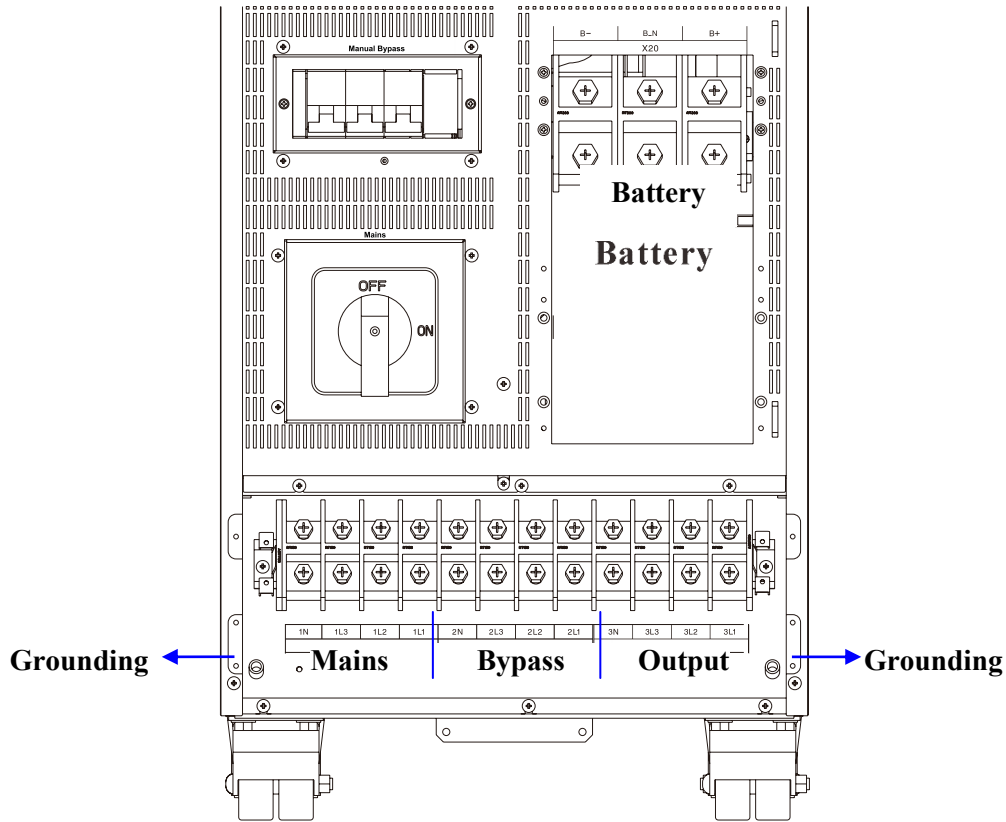

30-40kVA Power Terminal Positions

■ **Maximum Current Table**

Input/ Output Voltage	Output Power	Maximum Input Current ⁽¹⁾	Max. Output/Bypass Input Current ⁽²⁾	Max. Battery Discharge Current ⁽³⁾
200V	10kVA/10kW	33.8A	28.9A	70.4A
	15kVA/15kW	50.2A	43.3A	105.0A
	20kVA/20kW	67.2A	57.7A	140.0A
	30kVA/30kW	100.8A	88.7A	191.8A
	40kVA/40kW	134A	118.3A	255.8A
208 V	10kVA/10kW	32.5A	27.8A	70.4A
	15kVA/15kW	48.3A	41.6A	105.0A
	20kVA/20kW	64.6A	55.5A	140.0A
	30kVA/30kW	96.6A	85A	191.8A
	40kVA/40kW	128.6A	113.4A	255.8A
220 V	10kVA/10kW	30.7A	26.2A	70.4A
	15kVA/15kW	45.6A	39.4A	105.0A
	20kVA/20kW	61.1A	52.5A	140.0A
	30kVA/30kW	91.3A	80.3A	191.8A
	40kVA/40kW	121.5A	107.1A	255.8A

(1) The UPS is operating at rated voltage, rated power and batteries are charging but regardless of the overload.

(2) The UPS is operating at rated voltage and rated power but regardless of the overload.

(3) 12Vbattery blocks × 16pcs. The UPS is operating at rated voltage and rated power but regardless of the overload.

■ Minimum Recommended Size of Cables

Capacity	Mains Input ⁽¹⁾	Output/Bypass Input ⁽¹⁾	External Battery ⁽¹⁾
	R/S/T/N/PE	R/S/T/N/PE ⁽²⁾	B+/N/B-/PE
10kVA	10 AWG / 6mm ² TQ:22.1 Lb-in	10 AWG / 6mm ² TQ:22.1 Lb-in	6AWG / 16 mm ² TQ:53.1 Lb-in
15kVA	8 AWG / 10 mm ² TQ:22.1 Lb-in	8 AWG / 10 mm ² TQ:22.1 Lb-in	2 AWG / 35 mm ² TQ:53.1 Lb-in
20kVA	6 AWG / 16 mm ² TQ:22.1 Lb-in	6 AWG / 16 mm ² TQ:22.1 Lb-in	1 AWG / 50 mm ² TQ:53.1 Lb-in
30kVA	1/0 AWG / 67 mm ² TQ:53.1 Lb-in	1/0 AWG / 67 mm ² TQ:53.1 Lb-in	4/0 AWG / 107 mm ² TQ:88.3 Lb-in
40kVA	2/0 AWG / 67 mm ² TQ:53.1 Lb-in	2/0 AWG / 67 mm ² TQ:53.1 Lb-in	250 AWG / 127 mm ² TQ:88.3 Lb-in

(1) The recommended maximum length of cabling is less than 10meters.

(2) Always over size neutral line N by 1.7 times of the phase line for non-linear loads.

■ Minimum Recommended Circuit Breaker Size Table

Input/ Output Voltage	Output Power	Mains Input ⁽¹⁾	Output/Bypass Input ⁽¹⁾
200V	10kVA/10kW	40A	32A
	15kVA/15kW	50A	50A
	20kVA/20kW	80 A	63A
	30kVA/30kW	115A	100A
	40kVA/40kW	150A	125A
208V	10kVA/10kW	40A	32A
	15kVA/15kW	50A	50A
	20kVA/20kW	80A	63A
	30kVA/30kW	115A	100A
	40kVA/40kW	150A	125A
220V	10kVA/10kW	40A	32A
	15kVA/15kW	50 A	50A
	20kVA/20kW	63 A	63A
	30kVA/30kW	115A	100A
	40kVA/40kW	150A	125A

(1) Tripping curve C breaker is recommended.

(2) The sizing takes into account 150% overload capacity.

(3) Always use a curve D breaker for motor loads with high starting currents.

■ **Electrical System Connections**

- UPS with single input

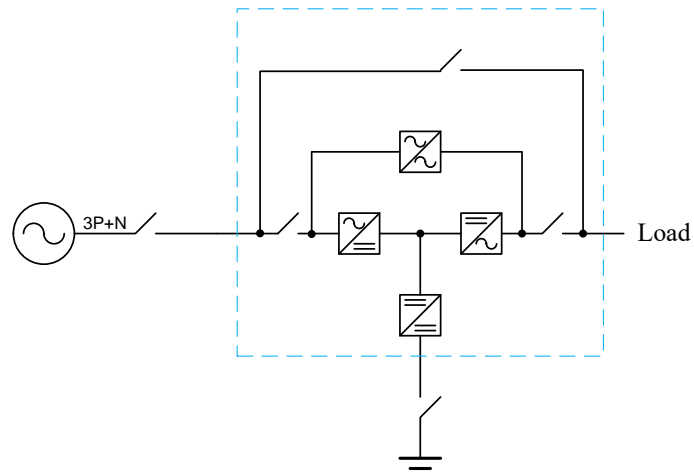

- UPS with single input and isolation transformer

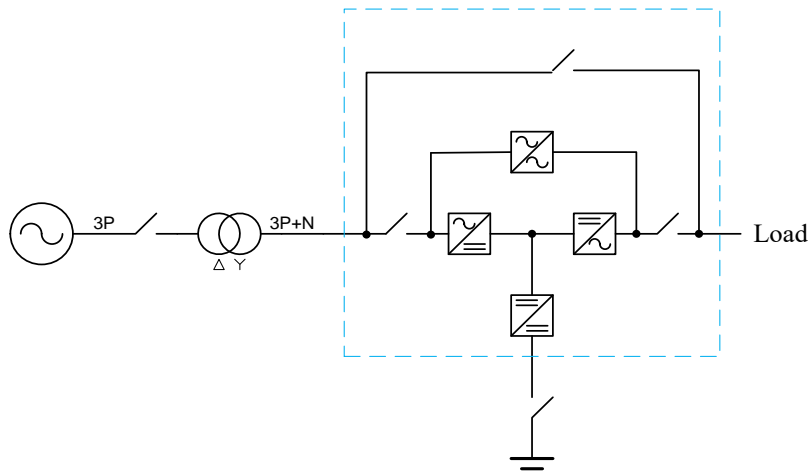

- UPS with dual inputs

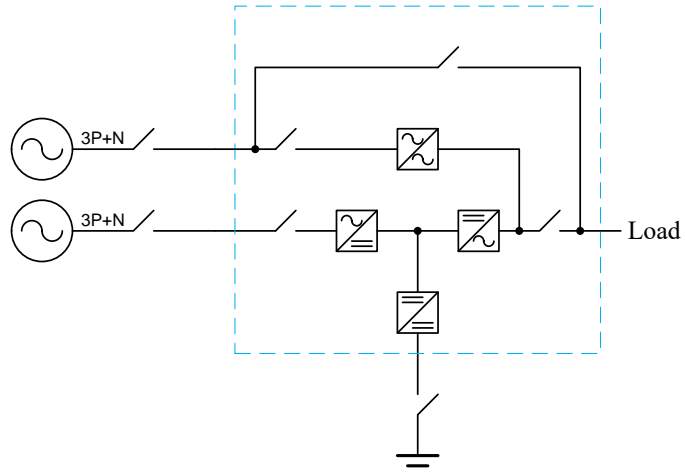

- UPS with dual inputs and isolation transformer

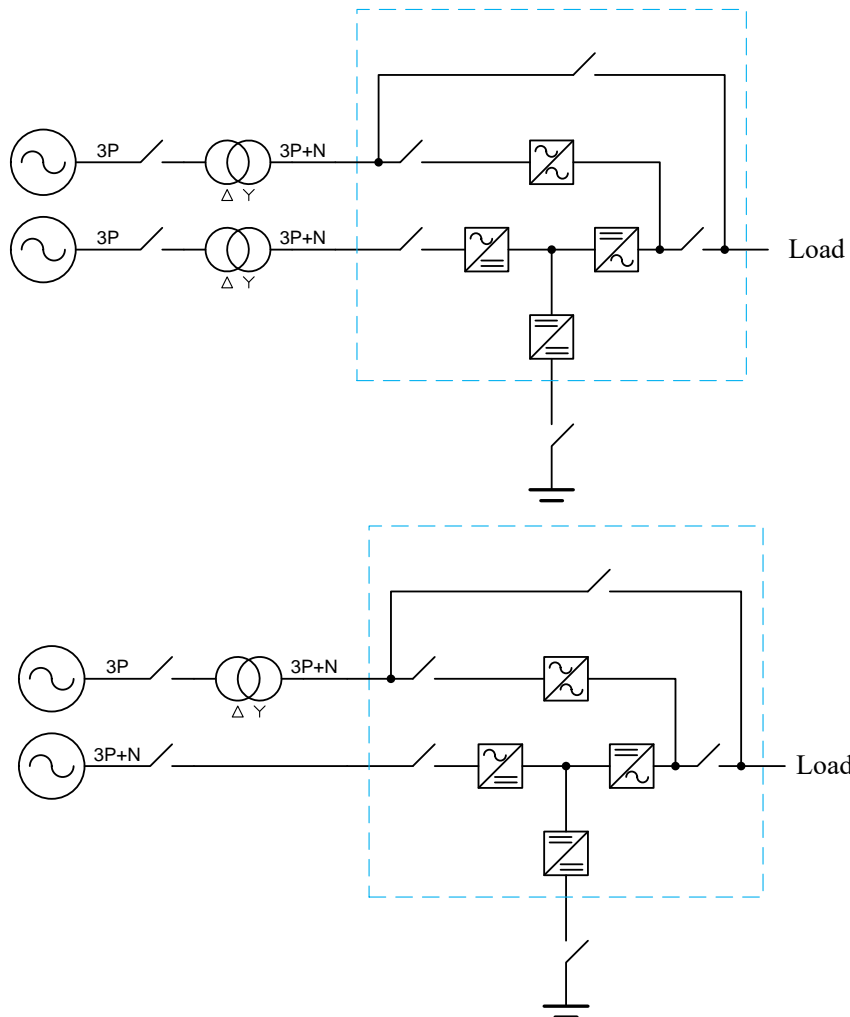

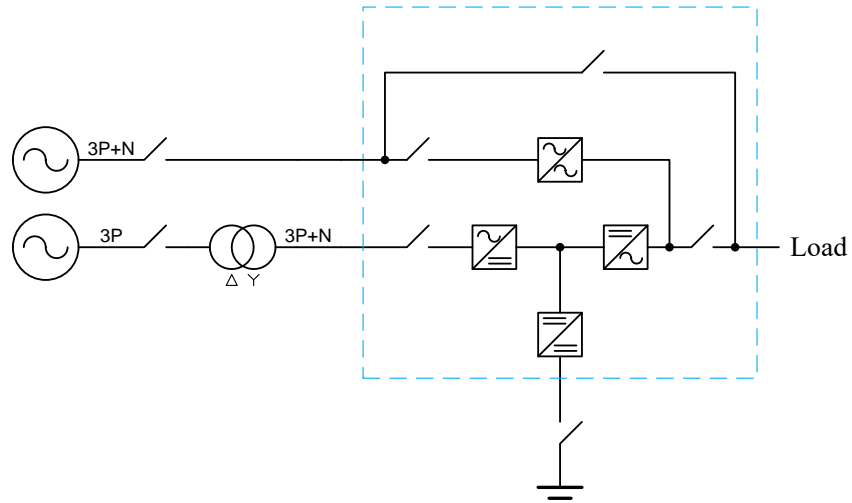

Note : You must install an isolation transformer on one of the inputs if the two power source are different.

- UPS in parallel, using separate battery

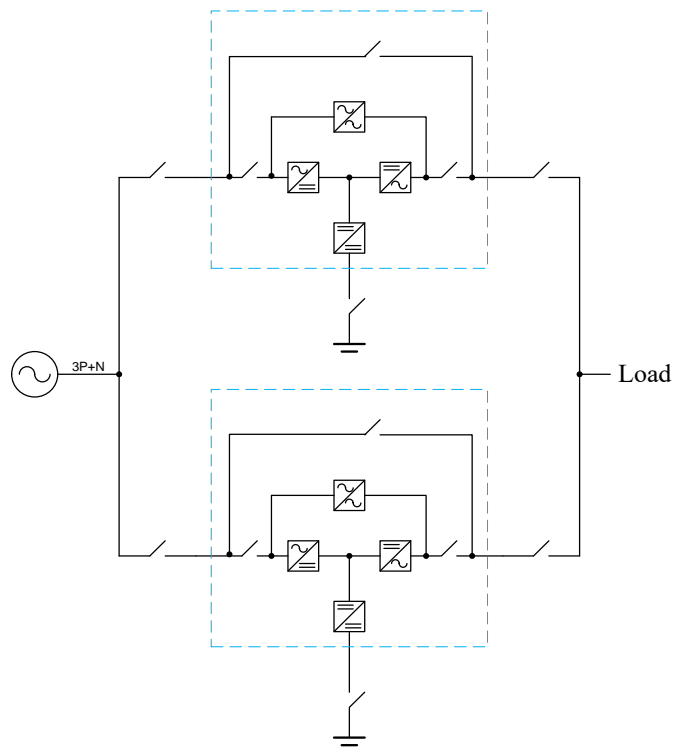

- UPS in parallel, using a common battery

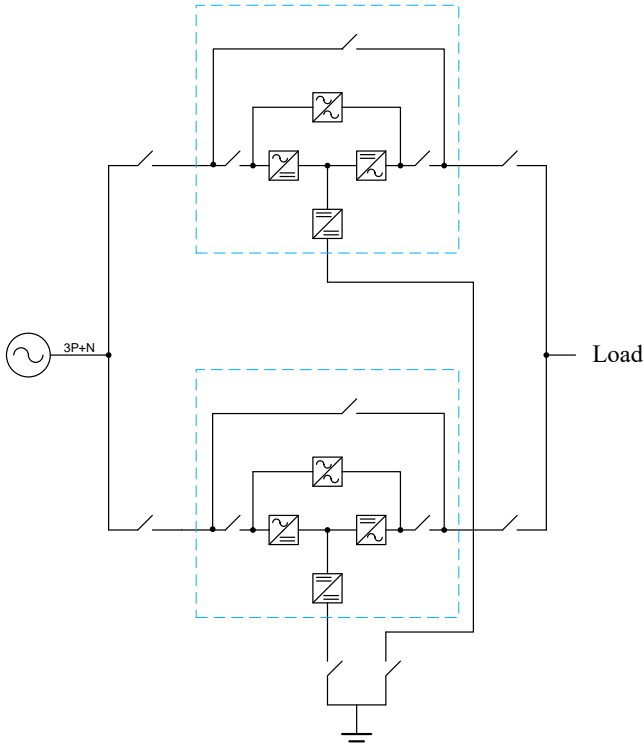

- UPS in parallel with an output transformer

Do not use individual output transformers for each UPS. A common output transformer must be used.

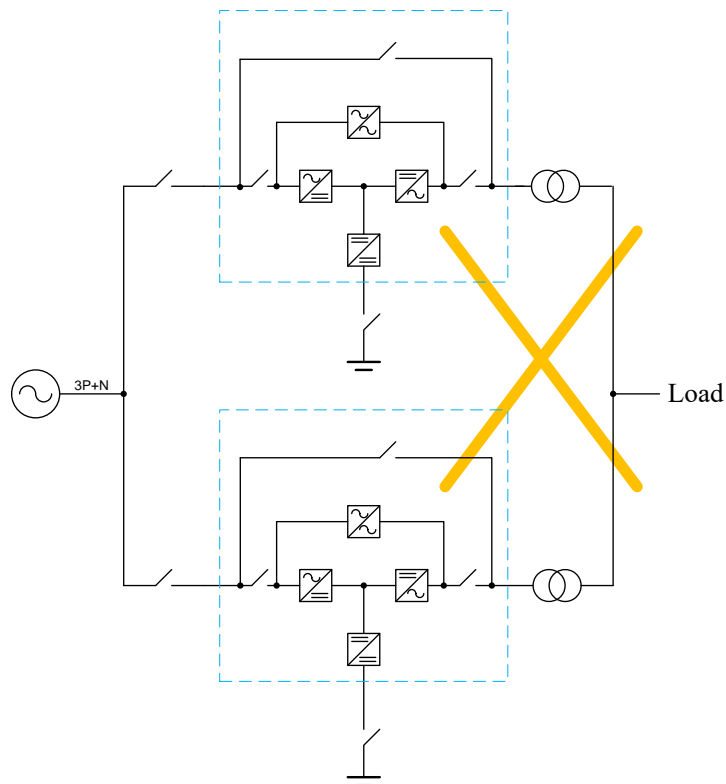
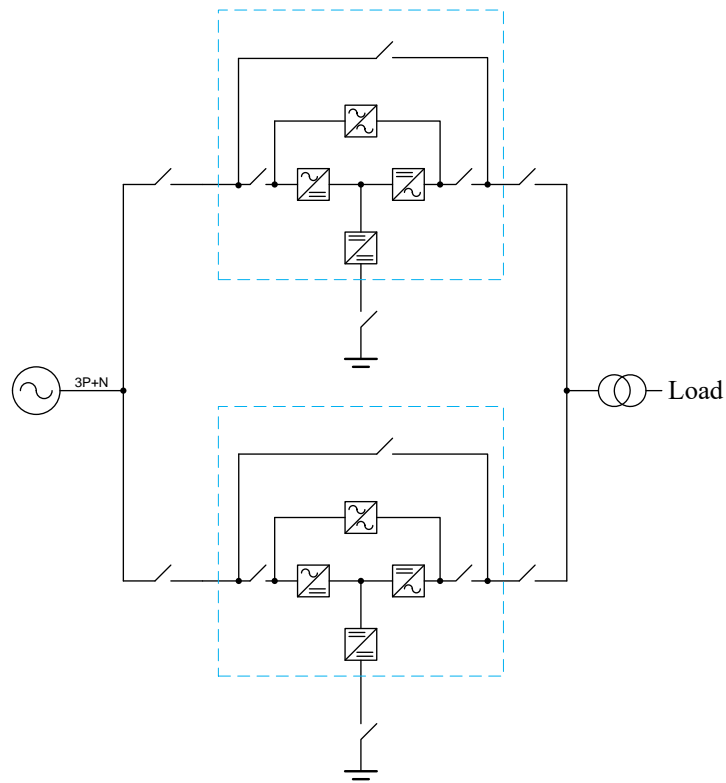

2.5 Auxiliary Power Supply Control Switch and Precharge Button

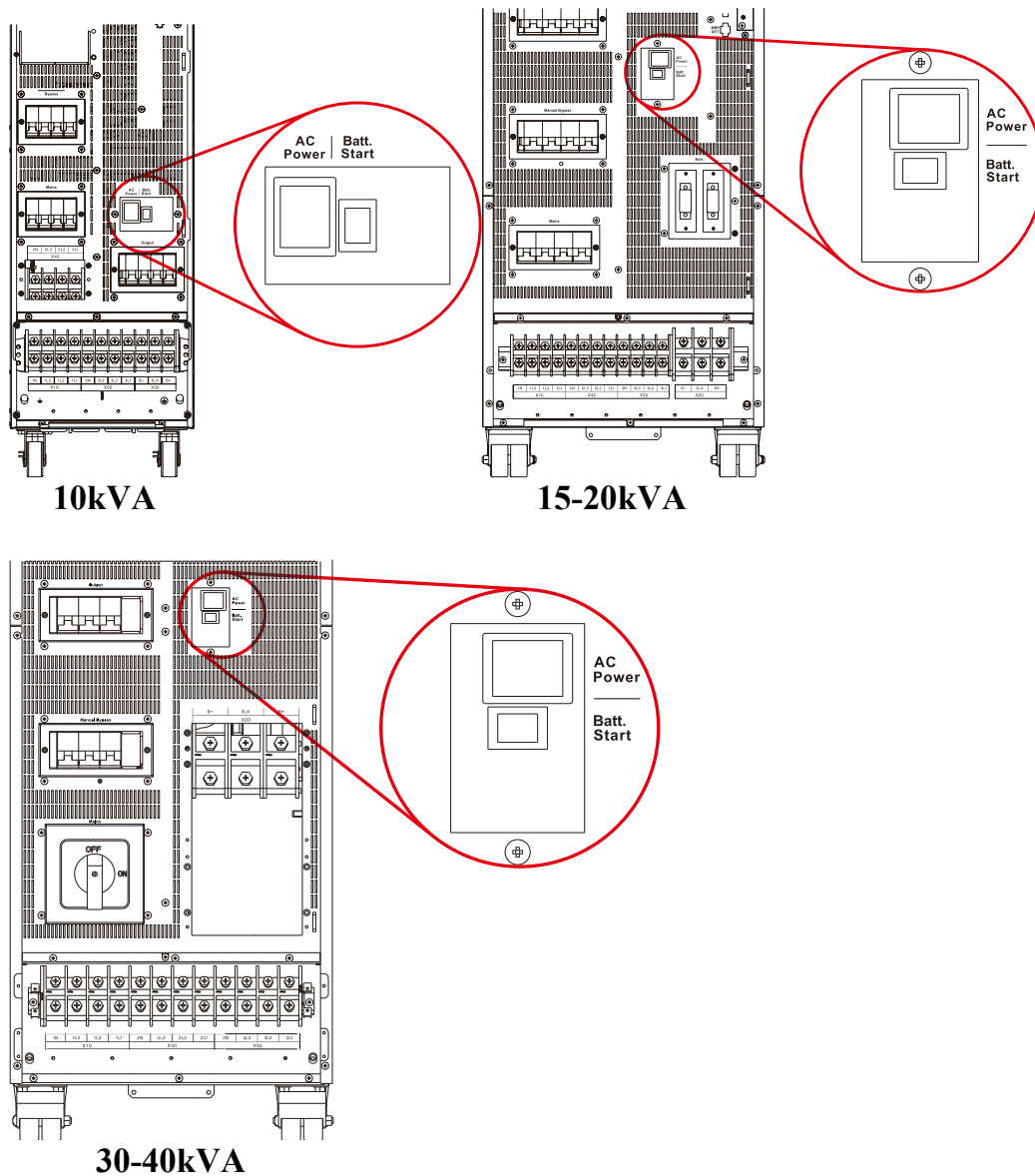

■ AC Power

This is auxiliary power switch for the main control power.

This Power switch is used first in sequence before turning on UPS. Don't switch this OFF at any time while the UPS is operating.

■ Batt. Start (Battery Cold Start)

The UPS will start-up using batteries when main input power is not available.

Always ensure the Battery Power switch is on before push this precharge button.

The detailed descriptions of above items is in section 3.4.2.

2.6 Communication Cables Connections

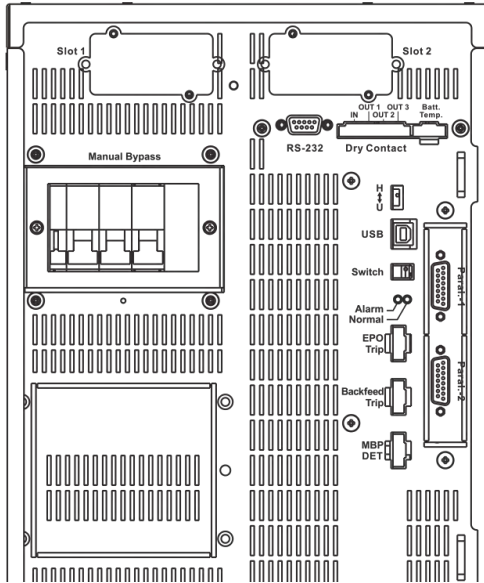

10kVA

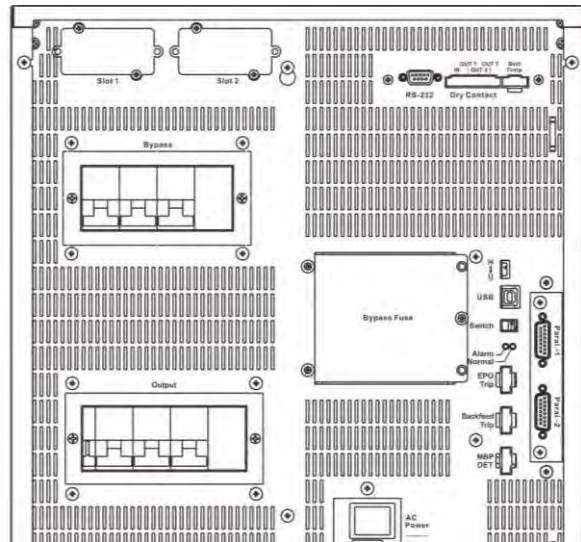

15-20kVA

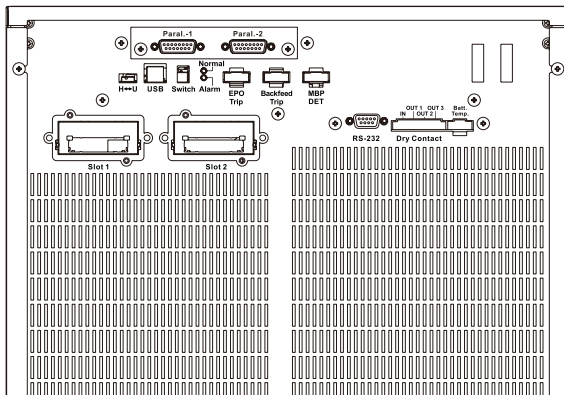

30-40kVA

■ Dry Contacts

The UPS provides 3 output dry contacts and 1 input contact.

Specification of Output dry contact : 250 VAC/ 2 A; 30 VDC/2 A

There are 3 jumpers (J1~J3) to set NC/NO for each output contact.

To short the input contact to send a command to the UPS.

The user can change the definition for each contact, please contact the local authorized service agent to change the setting.

Jumper (J1~J3) are displayed in Internal Top View (Please check section 1-2. UPS Outlook View).

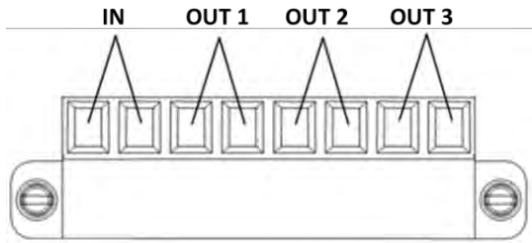

Default Definition	
General alarm	OUT-1
Load on inverter	OUT-2
Load on Bypass	OUT-3
Normal mode	IN

- **Communication Slot1**

This slot can will accept a Relay card or RS-485 MODBUS card.

- **Communication Slot2**

This slot will accept a Relay card or SNMP card. Always ensure that the SW2 switch is in the correct position when this slot is used.

- **Batt. Temp.--External battery temperature connector**

Connect to external battery temperature sensor. Please refer to section 5-4.

- **RS-232**

Pin Assignment:

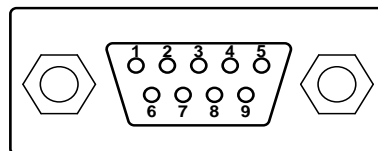

2→TX (OUT)
3→RX (IN)
5→Ground

Baud Rate	57600bps
Data Length	8 bits
Stop Bit	1 bit
Parity	None

This port is available for changing the settings of the UPS by setting software.

- **Paral-1&Paral-2—Parallel communication port**

Parallel communication cables are required to connect 2 or more UPSs' to each other in order to operate in parallel. Refer to section 2-7for detail connections.

- **H↔U—communication selector**

This switch is to select HMI or USB port. This switch must be in the “H” position in order for HMI port is function.

- **USB**

This port is for service only.

- **Switch—the switch for a terminal resistor for parallel communication**

To ensure good parallel communication quality, please set the switch of the two farthest UPS to the “ON” position. Please refer to section 2-7 for detail.

- **LED Status Indictors**

Normal: The UPS is normal.

Alarm: The UPS has an abnormal condition(s).

- **EPO-- Emergency Power Off**

This EPO contact allows you to turn off the UPS in case of emergency. Short this contact to turn off the UPS immediately.

- **Backfeed Trip**

The UPS provides a backfeed protection contact to trip the external electromechanical device for isolation from the power circuit. The backfeed protection is to ensuring personnel safety against any risk of accidental energy returning to the input circuit. It imposes the automatic opening of a switching device in case of a malfunction of the static switch.

- **MBP Det.**

If an external manual bypass switch has been installed with UPS system, this detector must be connected to the auxiliary contact of the external manual bypass switch.

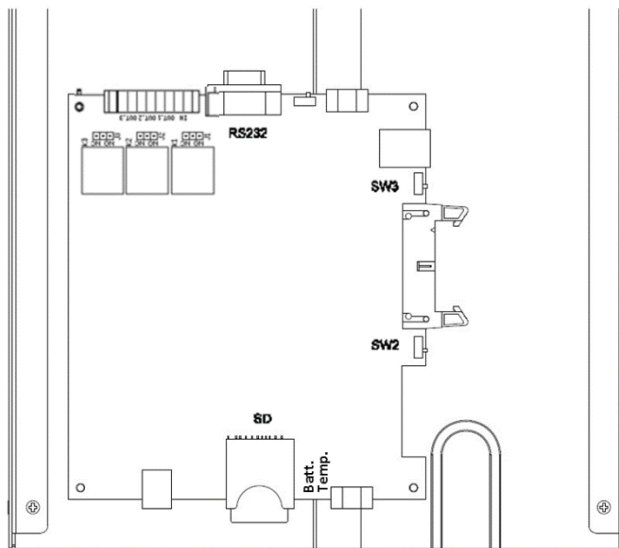

- **SW2**

When the Relay Card is installed in Slot 2, move the switch to “Slot” position.
When SNMP card is installed in Slot 2, move the switch to “SNMP” position.

- **SW3--the switch for terminal resistor of parallel communication**

To ensure a proper parallel communication connection, the selector switch on each of the additional UPSs', starting from the furthest UPS, must be moved to the “ON” position. Please refer to section 2-7 for detail.

2.7 UPS Parallel Connections (Option)

The Kronos UPS may be operated in parallel to increase its capacity and also adds redundancy and increases the system's reliability.

- Up to 6 UPS units may be connected and operated in parallel.
- Each UPS requires the additional of the parallel card (Option).
- The size and length of the AC input and output cables must be identical for all UPS units.
- The phase rotation must be the same for each UPS unit.
- It is recommended to use an external bypass cabinet to facilitate maintenance and system testing for parallel operation system.
- Parallel configuration must be performed by authorized and qualified technicians who are familiar with this the Kronos UPS.
- Parallel cables must be installed in order for each to UPS to communicate with each other.
- Only use the parallel communication cables which are supplied with Kronos UPS to ensure that the UPS will operate properly in a parallel configuration.
- The parallel communication cables must be connected in a ring configuration. The maximum total length of the parallel communication cables must be less than 38 meters. To ensure good communication quality you must set the Switch & SW3 of the two furthest UPS to the "ON" position as shown in below. (Please reference to section 2.6 for SW3)

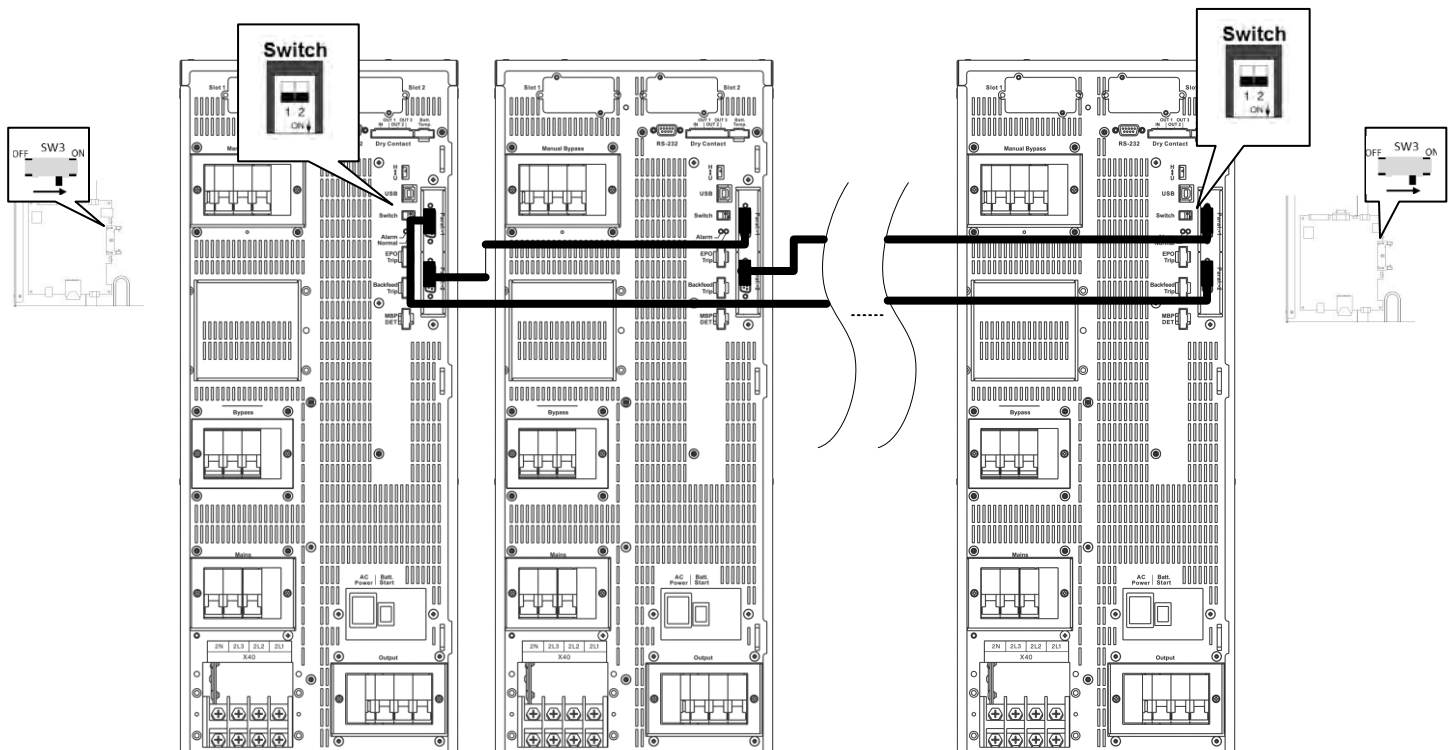

- Parallel communication cables connected are shown below.

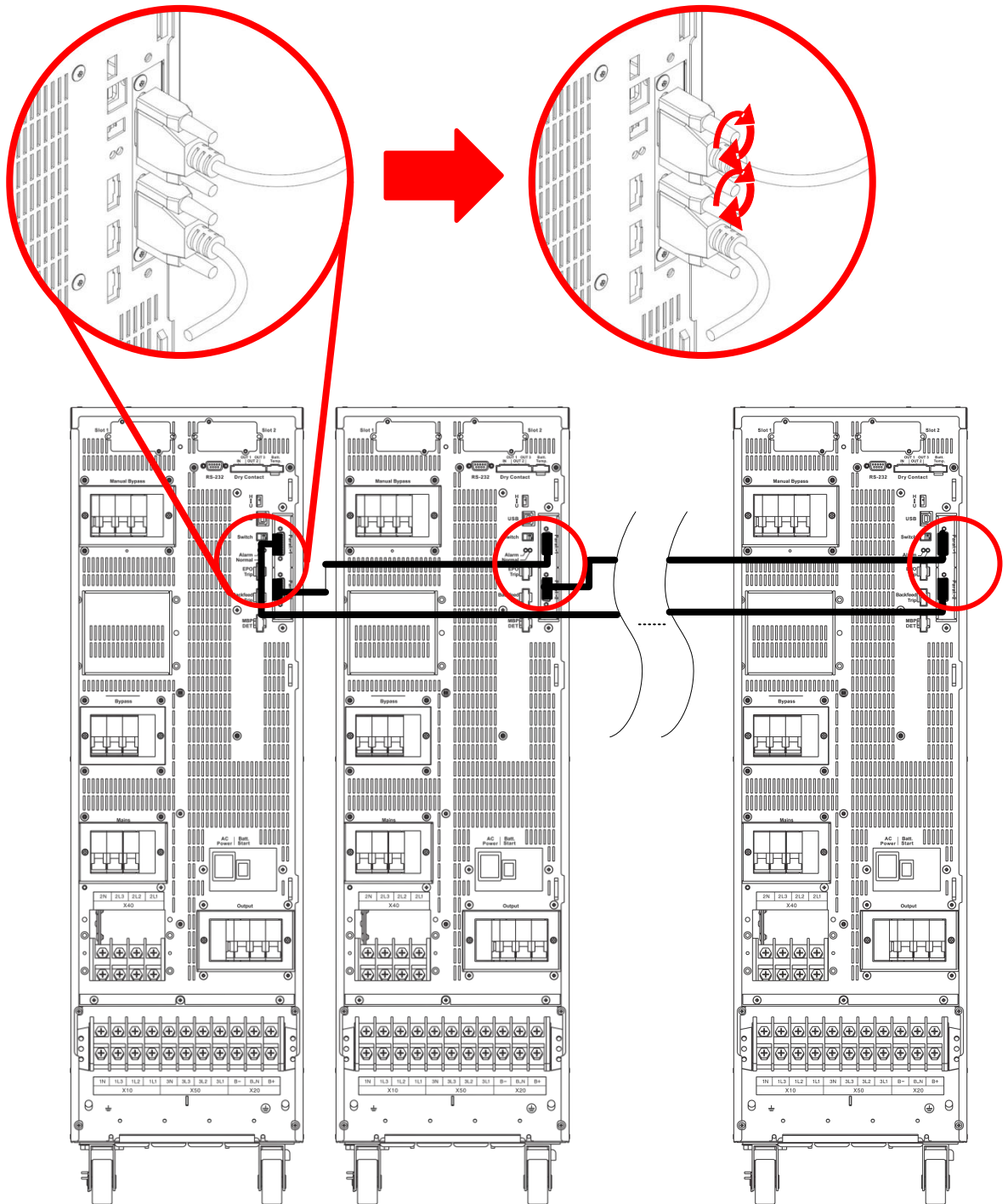

■ Recommended 1+1 parallel system configuration

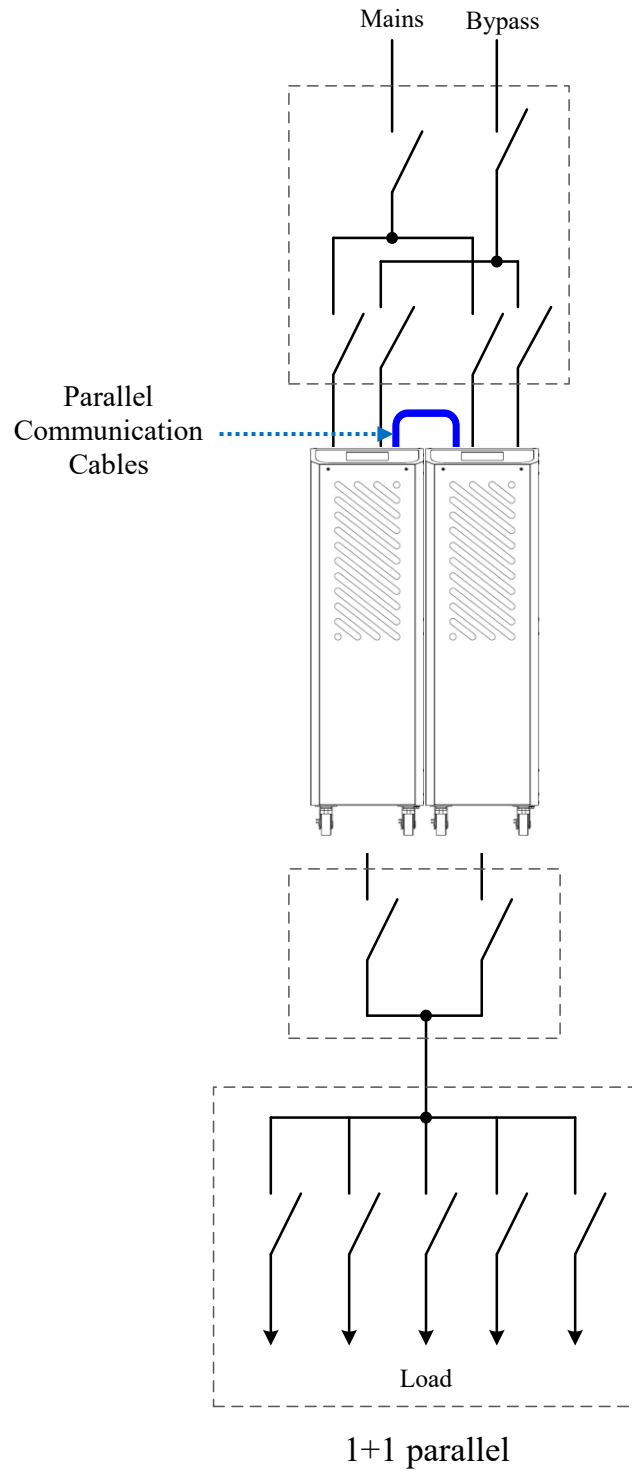

■ Recommended N+1 parallel system configuration

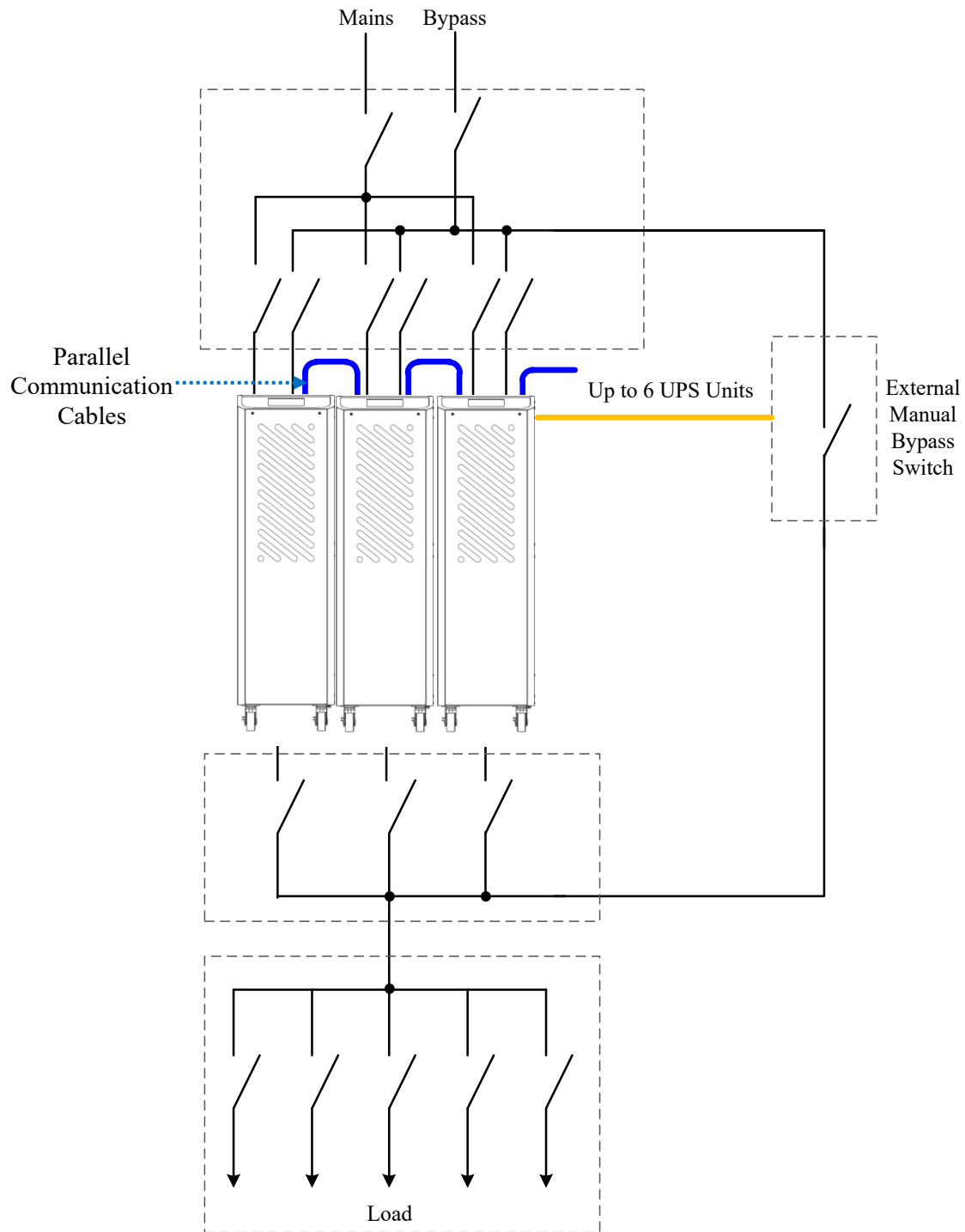

3. Kronos Operation And Descriptions

3.1 Operating Mode

The UPS provides the following operating modes:

- **Normal Mode(Online Mode)**

In Normal mode, grid power is passed through Rectifier then used to charge the battery and provide power through the Inverter simultaneously. Different output voltages settings can be set in VFI mode. The three options are 200/115V, 208/120V and 220/127V. These can be fine-tuned by $\pm 8V$.

- **Economy Mode (ECO)**

Economy Mode effectively improves overall efficiency. In ECO Mode grid power is routed through the Static Switch to the load. At the same time, grid power continues to charge the battery in DC/DC mode through Rectifier following the same setup as VFI Mode. Inverter is also kept ready to switch power supply modes at any time. If VFI mode is set then power can be quickly routed from Bypass to Inverter.

Attention: In ECO Mode, the power supply frequency and voltage will be less stable. Always verify the load requirements and use ECO Mode with care.

- **Converter Mode**

Converter Mode allows the user to provide a power supply with constant voltage and constant frequency based on their power requirements. The frequency can be set to 50Hz or 60Hz. The voltage options are 200/115V, 208/120V and 220/127V. These can be fine-tuned by $\pm 8V$. When the Converter mode is used and in the event of grid power failure, the power will be provided from the battery in Back-up mode. In the event of the battery running low, UPS overload, Inverter failure or module overheating, the entire system will shut down.

3.2 Online Operations

The Kronos online UPS provides stable power that is not affected by an unstable main power supply (eg. grid power). Through the Kronos online UPS, the power provided is a clean, noise-free power source.

The online architecture offers three types of power supply methods depending on the power environment.

■ Normal Mode

When grid power is normal, once Rectifier has been turned on at the main power supply then the battery is charged in DC/DC mode while the required power is supplied via Inverter at the same time.

■ Bypass Mode

In the event of UPS overload, Inverter failure or module overheating, the power supply circuit switches from Inverter to the bypass output.

■ Battery Mode

When the UPS detects a failure in the main power supply then power is provided from the battery instead. The touch screen at the front of the module will also display current battery level to remind the user.

3.3 Manual Bypass Operation

When the manual bypass breaker is activated, the load is powered directly from the bypass input. This operation is useful when maintenance needs to be carried out on UPS allowing the technician to perform the complete service without having to disconnect the power to the load.

Attention:

- *UPS maintenance can only be performed by authorized and qualified technicians who are familiar with this UPS.*
- *If the UPS is in battery mode, closing or changing the position of the manual bypass breaker will cut off power to the load.*

3.4 Operating Processes

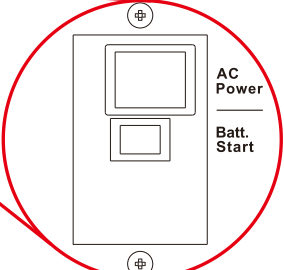
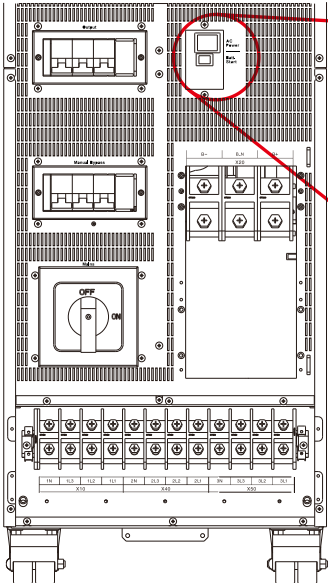
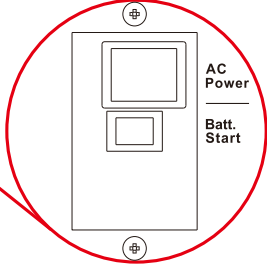
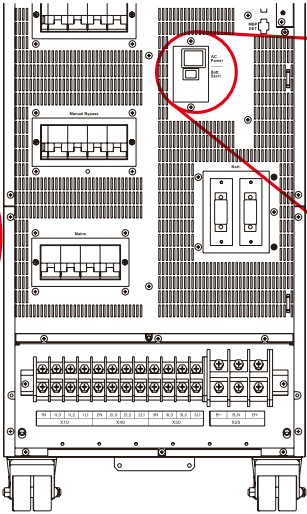
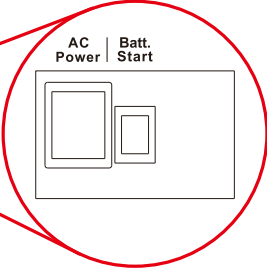
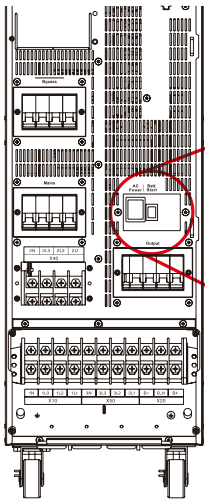

3.4.1 Normal Mode Start-up

- (1) On the rear of UPS, switch ON the **AC Power** switch.
- (2) Close UPS Mains Input Breaker/Switch and Bypass Input Breaker if equipped.



- (3) Select  → Command → Operation → Normal Mode on LCD display.
- (4) Return to the Mimic Display. Wait for few minutes, the rectifier will have started.



- (5) Close the battery switch/fuses to connect the batteries after rectifier has been turned on.



(6) The inverter will have started and supply output voltage.

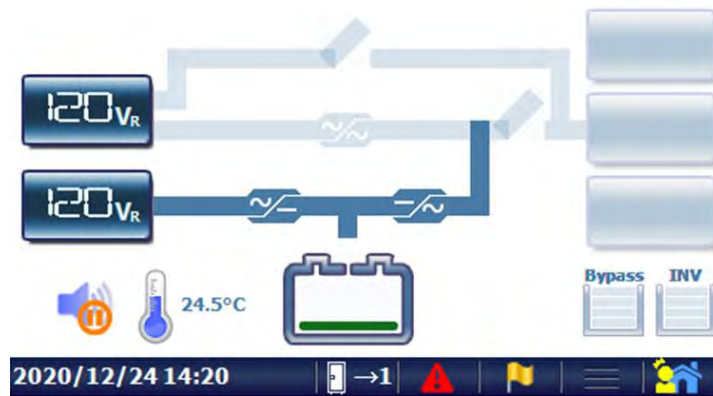

(7) Close the UPS Output Breaker to supply the power to the load.



3.4.2 Cold Start

- (1) User can start-up the UPS using the battery when main input power is not available.
- (2) If the UPS is with an external battery configuration, it is imperative that the batteries are connected.
- (3) On the rear of UPS, push button and hold down the button that indicates “**Batt. Start**” for a minimum of 10 seconds.
- (4) Select → **Command** → **Operation** → **ColdStart Precharge Ready** on LCD display.
- (5) Select **Normal Mode** to start UPS.
- (6) Once UPS working in Normal Mode.

3.4.3 Shutdown

- (1) Select → **Command** → **Operation** → **Shutdown** on LCD display.



Attention:

- **IMMEDIATE LOAD OFF!**
- **For turn off the working power, switch OFF both AC Power and Batt. Power switches in the rear of UPS.**



3.4.4 Switch to bypass

- (1) Select  → **Command** → **Operation** → **Loadon Bypass** on LCD display.
- (2) The Inverter will be shutdown and the bypass will supply the power to the load. If the battery is disconnected, Rectifier and Charger will be shutdown as well.

3.4.5 Switch from normal mode to maintenance bypass

- (1) Select  → **Command** → **Operation** → **Loadon Bypass** on LCD display.
- (2) The Inverter will be shutdown and bypass will supply the power to the load.
- (3) Open/disconnected the external battery Switch/fuses if equipped.
- (4) Close the maintenance bypass switch.
- (5) Select  → **Command** → **Operation** → **Shutdown** on LCD display.
- (6) Open Output and Mains/Bypass Input breaker.
- (7) On the rear of UPS, switch OFF **AC Power** and **Batt. Power** switches.

3.4.6 Maintenance bypass → normal mode

- (1) On the rear of UPS, switch ON **AC Power** switch to start the working Power.
- (2) Close the Output and Mains /Bypass Input breaker.
- (3) Select  → **Command** → **Operation** → **Loadon Bypass** on LCD display.
- (4) Open maintenance bypass breaker.
- (5) Select  → **Command** → **Operation** → **Normal Mode** on LCD display.
- (6) Return to **Mimic Display**. Wait for a few minutes, the rectifier will start and the icon  will show you when can close the Battery line switch/fuses to connect the batteries.

4. Control Panel Operation and Function Description

Each Kronos UPS is equipped with an LCD touch panel to provide the user with a simple and intuitive user interface that is easy to learn. The touch panel offers a combination of graphics and numbers that make it easy to determine the input/output voltage, frequency, load and battery level at a glance. The current status of the UPS is displayed at the main screen. More detailed information such as real time input/output voltage, frequency, current and battery information from the touch panel.

Refer to the selection below for detailed information and functions viewed using the LCD touch panel.

4.1 Screen Introduction



【A】 Displays the current time, status and information of the UPS.

【B】 Indicates Single or Parallel systems, and selects the identified UPS unit to check the parameters.



: Single Unit



: Parallel System

【C】 Click here to view the alarm message.



: The green pattern indicates that UPS is normal.



: The red pattern indicates that UPS an abnormal condition has occurred.

【D】 Click to view the status.

【E】 Enter for Sub-Menu, please refer to section 4-2 for more details.

【F】 Enter for Menu, please refer to section 4-2 for more details.

4.2 Menu

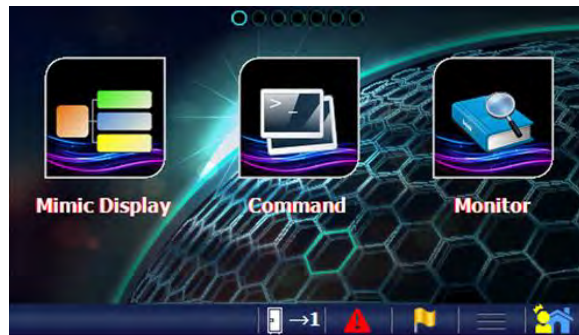

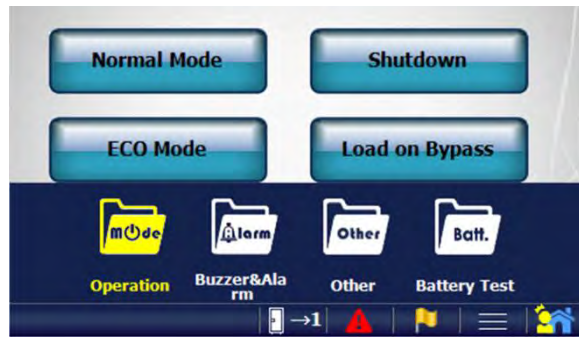

Click  to enter to the Menu screen as shown in above picture. Slide the screen to select the menu page and click the menu icon to enter to the desire function.

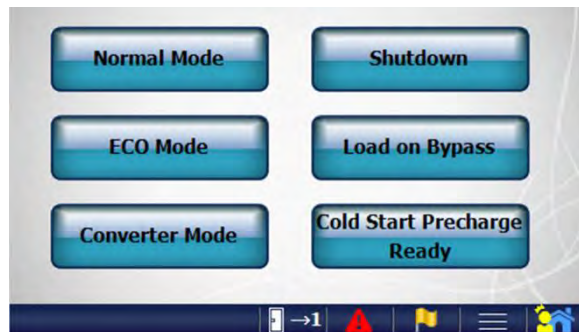

Click  to hide/show the sub-menu.



The button below will appear on some of the function pages.

Button	Function
	Click it to save the new setting
	Click it to reload the data
	Click it to go to Mimic Display

■ All menu functions are in the table below.

Menu	Sub-Menu	Functions
Mimic Display		Displays the UPS status 、 alarm 、 operating mode and measurements. Please refer to section 4-3 for more detail.
Command ⁽¹⁾	Operation	<ul style="list-style-type: none"> • Normal Mode • ECO Mode • Converter Mode • Shutdown • Load on Bypass • Cold Start Precharge Ready
	Buzzer & Alarm	<ul style="list-style-type: none"> • Enable/Disable buzzer • Clear Latch Alarm and Buzzer
	Other	<ul style="list-style-type: none"> • Force Charger on • Recovery Backfeed Protection Signal • Clear UPS Maintenance Alarm
	Battery Test	<ul style="list-style-type: none"> • Battery Test. • Turn off The Battery Test.
Monitor	Identification	Displays UPS information
	Real Time Information	Displays real time measurements of input, output, bypass and battery.
	Maintenance Code	Displays the maintenance code for technician to check the status of the UPS.
	Version	Displays the control MCU software and firmware version.
Configuration	Alarm	Set alarm latch function. <ul style="list-style-type: none"> • General Alarm • Mains Alarm • Bypass Alarm • Over Temperature • Vbatt. Low • Inverter Overload • Bypass Overload • EPO Activated
	Main	Select the measurements on the Mimic Display.
	Bypass	
	Output	

Menu	Sub-Menu	Functions
Management	Schedule	Displays the schedule.
	Schedule Setting ⁽¹⁾	To define the schedule for ECO mode.
	Battery Test Schedule ⁽¹⁾	To define the schedule for battery test.
Setting	Language	Select the display language
	Update Prog.	Upgrade the software of LCD touch display.
	General	Set the turn off time of LCD backlight.
	Date and Time	Set date and time.
	Peripherals ⁽¹⁾	Set communication card.
	Parameters ⁽¹⁾	UPS the parameters which can be modified.
Event Log		Display the event log list of UPS.
Permission Setting	Login/Logout	Login with the password ⁽²⁾
	Password Modification ⁽¹⁾	Change user password.

(1) This function menu only appears after login; please refer to “Permission Setting”.

(2) Default password is “3366”.

■ **Enter in the Parameters Page**

From the menu, enter in the Setting Icon then tap the blue row to see additional Parameters



Use the login password (Default is: 3366) then press enter



You will not be able to modify the UPS parameters. Make sure that the converters are off in order to save them.



The UPS parameters that can be modified by the user using the control panel are listed in the table below.

Parameters	Content	Range	Default
Battery	Independent/Common	Ind. / Common	Common
	Total cell number	96 ~ 120	120
	Capacity	1~1000	88
	Voltage Temperature compensation	Yes / No	No
	Detect the Battery connecting	Yes / No	Yes
	Charger current	0.0~1.0	0.1
	CV Charger voltage [V/cell]	2.000~2.550	2.300
	FV Charger voltage [V/cell]	2.000~2.550	2.250
	Vbatt. Low [V/cell]	1.850 ~ 1.883	1.850
	Vbatt. Min [V/cell]	1.600 ~ 1.900	1.670
	Battery test 2 minutes	Yes / No	Yes
Output	Output voltage	115 、 120 、 127	120
	Output frequency	50 、 60	50
	Fine adjustment voltage	-8 ~ 8	0
Transformer	Input transformer	No / Mains & Bypass	No
	Input transformer ratio ⁽¹⁾	0.00~10.00	0
	Output transformer	No / Yes	No
	Output transformer ratio ⁽¹⁾	0.00~10.00	0
Other	Unit number	1 ~ 6	1
	Number of units in parallel system	1 ~ 6	1
	Set EPO logic	NO/NC	NO

(1) Transformer ratios can be calculated as following,

Input transformer ratio = V_{p_in}/V_{s_in} ; Output transformer ratio = V_{s_out}/V_{p_out}

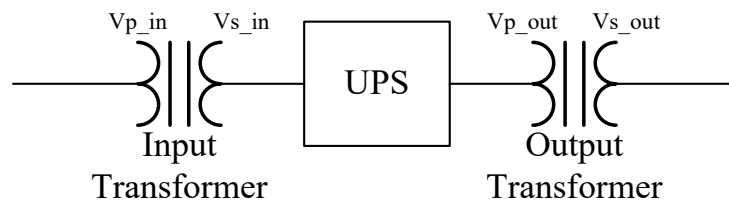

4.3 Mimic Display

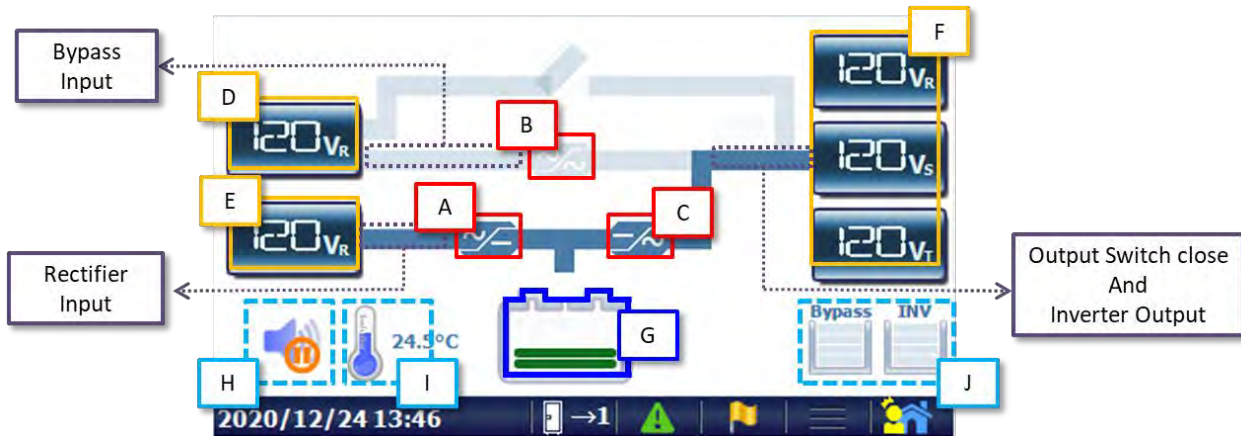

【A】 is Rectifier 、 【B】 is Static Switch and 【C】 is Inverter.

The faded pattern indicates this part isn't activated.

The blue pattern indicates this part is activated.

The red pattern indicates this part is currently in an abnormal condition.

【D】 Displays the bypass input measurements.

【E】 Displays the mains input measurements.

【F】 Displays the output measurements.

The abnormal measurements will have red background

Click 【D】 【E】 【F】 to change the measured parameter and press for 3 seconds to enter to Real Time Information.

【G】 Display the status of battery.

Press it for 3 second to enter to Real Time Information.

The battery isn't connected.

The green pattern indicates the battery is charging.

The yellow pattern indicates the battery is discharging.

【H】 Alarm silence button. Click it to silence the alarm and press for 3 seconds to enable/disable the buzzer.

Buzzer is enabled and Buzzer is disabled.

【I】 Displays UPS internal temperature.

Press for 3 seconds to enter to Real Time Information.

【J】 Overload counter

5. Options

5.1 Dry Contact Card



This card provides six output dry contacts and six input contact. These contacts are programmable and user can change the definition for each contact. Please refer to Dry Contact Card manual for more detail.

5.2 RS-485 MODBUS Card



RS-485 ports with JBUS/MODBUS protocol. Please refer to RS-485 Card manual for more detail.

5.3 SNMP Card



This is the Ethernet network card with TCP/IP, HTTP and SNMP protocols.

5.4 Temperature Sensor



Measure the battery temperature.

5.5 Parallel Communication Card

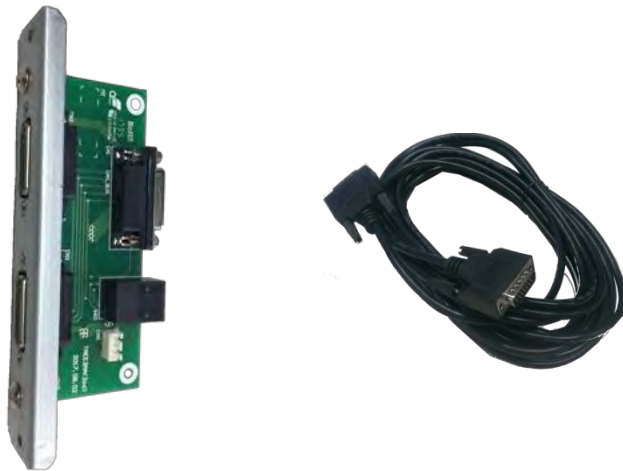

The parallel communication cards are required when 2 or more UPS are in parallel. Also included is a 1.5 meter parallel communication cable.

A longer parallel communication cable is available when multiple UPS are in parallel.

6. Troubleshooting

In the event of failure, the display area on the control panel will highlight the problem area in red. The “Alarm” symbol  will also blink to warn that there is a problem with the UPS.

Click  to have an alarm list as below picture.



We recommend using the following method when troubleshooting to export **the event log and machine information** from LCD panel to the SD card.

6-1. Export machine information from LCD panel

1. Make sure the SD card has been inserted on the LCD panel.
2. On the LCD, select  → **Management** → **Export** → **Export Unit Info and Settings**.

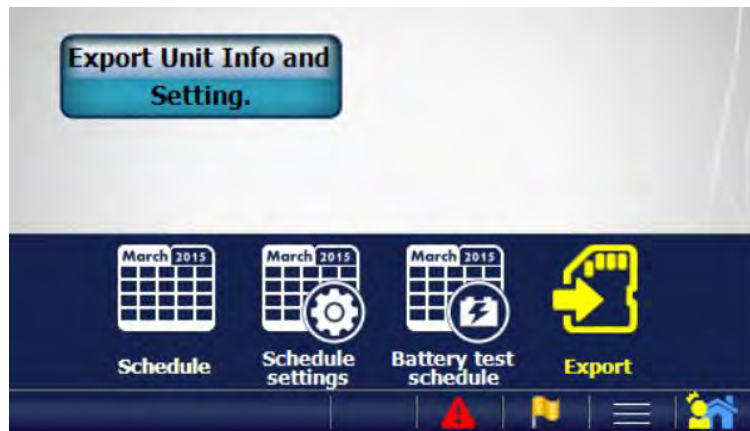

3. On the LCD, it will indicate " Export Unit Info and Setting. ? ". Then select " Enter ".
4. The information and setting data will be saved on SD card named *xxxx_KL_xx_IDx_XXXXXX_Inf.mch*, please send it to your technical support.

6-2. Exporting The event log from LCD panel

1. Make sure the SD card has been inserted on the LCD panel.
2. On the LCD, select  → Event Log.

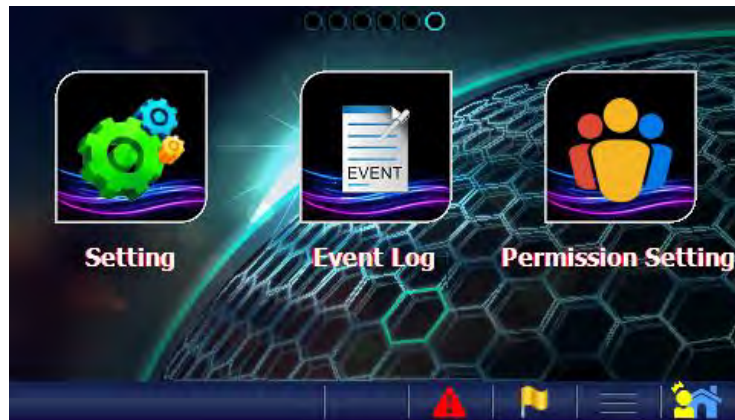

3. Before exporting, you need to refresh the log on LCD. Touch here for refreshing.



4. After all log have been displayed on the LCD, touch and hold again for 2 seconds.
5. LCD will show " Export ? ". Then select " Enter ".
6. The event log will be saved on SD card named *xxxx_KL_xx_IDx_XXXXXX_Log.txt*, please send it to your technical support.

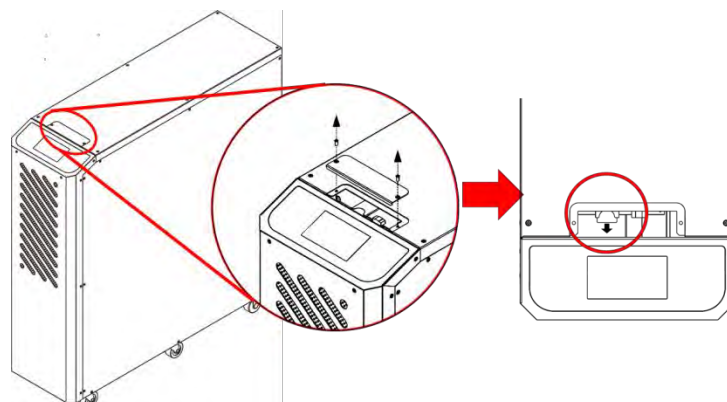

7. Technical Specifications

Capacity		10kVA	15kVA	20 kVA	30kVA	40kVA
Input						
Voltage	208V _{LL} 3 Phase + N					
Voltage Tolerance	±25% @100% load, -40% ~-20% @50% load Output capacity decrease linearly according to the input voltage					
Frequency	40 ~ 70Hz					
Power Factor	≥ 0.99					
THDi	≤3% @ 100% load					
Output						
Voltage	200/208/220V 3 Phase + N					
Voltage Tolerance	±1% (Static Load)					
Frequency	50/60Hz					
Frequency Tolerance	±1% (free running)					
Power Factor	1.0					
Crest Factor	3:1					
Voltage Harmonic Distortion	≤ 1.5% with linear load					
	≤5% with distorting load					
Overload	110% for 60 minutes, 125% for 10 minutes, 150% for 1minutes (<105% overload continuously without alarm, >= 105% <110% continuously with alarm)					
Bypass						
Voltage	200/208/220V 3 Phase + N					
Voltage Tolerance	Preventive range ±10% (Adjustable ±5% ~ ±15%) Critical range ±25% (Adjustable ±16% ~ ±30%)					
Frequency	50/60Hz					
Frequency Tolerance	±1Hz / ±3Hz (Selectable)					
Battery						
Number of batteries	12V,16/18/20pcs configurable					
Max. Charging Current(1)	100% Load	3.5A	5A	7A	10A	13A
	<60% Load	10A	15A	21A	31A	42A
Common Battery for Parallel Configuration	Yes					
Internal Battery	Available for housing 12V 7/9Ah 20pcs x 2 strings	Available for housing 12V 7/9Ah 20pcs x 3 strings			N.A	
Maximum Efficiency						
VFI Mode	93.5%	94%	94.5%	94.6%	94.6%	
ECO Mode	98%					
Backup	92.5%	94%	94.5%	93.5%	94.3%	

⁽¹⁾Provides more charging current with less load condition.

Capacity	10kVA	15kVA	20 kVA	30kVA	40kVA
HMI & Communication					
Display and MMI	4.3" Colorful LCD Touch Screen				
Built-in Communication Port	RS-232, EPO, Dry Contacts				
Optional Communication	2 Communication Slots for SNMP Card, RS-485 MODBUS Card, Dry Contact Card				
Mechanical Characteristic					
Dimensions (W x D x H) mm	260 x 850 x 890	410 x 850 x 977		410 x 850 x 1250	
Weight (w/o battery)	83kg	105 kg	115 kg	155 kg	160 kg
Protection Grade	IP20				
Color	RAL 9005				
Environment					
Storage Temperature	-20~70°C (UPS w/o battery) -15~40°C (UPS with battery)				
Storage Humidity	≤ 95%				
Operation Temperature	0~40°C 20~25°C (Recommended for optimum battery performance; Battery life is halved for every 10°C increase above 25°C)				
Operation Humidity	0 ~ 95% (w/o condensation)				
Operating Altitude	<1000 m without derating ⁽¹⁾				
Tested to standards	UL 1778, Fifth Edition, and CAN/CSA C22.2 No 107.3-14, Third Edition.				
	TEST to standards : FCC part 15 Class A · EN/IEC 62040-2 C2				
Mark	UL/cUL, FCC				
Noise (at 1 meter)	<55dBA			<60dBA	

⁽¹⁾Over 1000m above sea level, the maximum output capacity must be derated by 1% every additional 100m.

Appendix

No. and type of battery

Battery Manufacturer		Rating	Battery Case Flame Rating
TAIWAN YUASA BATTERY CO., LTD. (MH28947)	NPW45-12	12Vdc, 7.5Ah	HB
	NPW45-12FR	12Vdc, 7.5Ah	V- 0
	NPW36-12	12Vdc, 7.0Ah	HB
	NPW36-12FR	12Vdc, 7.0Ah	V- 0
	NP7.2-12	12Vdc, 7.0Ah	HB
	NP7.2-12FR	12Vdc, 7.0Ah	V- 0
SHENZHEN LEOCH BATTERIES TECHNOLOGY CO LTD (MH26866)	DJW12-5.0	12Vdc, 5.0Ah	HB
	DJW12-7.0	12Vdc, 7.0Ah	HB
	DJW12-9.0	12Vdc, 9.0Ah	HB
FIAMM ENERTECH CO LTD (MH27960)	12FGHL28	12Vdc, 7.2Ah	V- 0
	12FGHL34	12Vdc, 8.5Ah	V- 0
B&B BATTERY (USA) INC. (MH19884)	HR9-12/FR	12Vdc, 8.0Ah	V- 0
HITACHI CHEMICAL ENERGY TECHNOLOGY CO LTD (MH14533)	GP 1245	12Vdc, 4.5Ah	HB
	GP 1245 FR	12Vdc, 4.5Ah	V- 0
	GP 1272	12Vdc, 7.2Ah	HB
	GP 1272 F2 (12V 28W)	12Vdc, 28W/cell	HB
	GP 1272 (12V 28W)	12Vdc, 28W/cell	HB
	GP 1272 FR (12V 28W)	12Vdc, 28W/cell	V- 0
	GP 1272 FR	12Vdc, 7.2Ah	V- 0
	GP 1272 F2FR (12V 28W)	12Vdc, 28W/cell	V- 0
	HR 1234W	12Vdc, 8.5Ah	HB
	HR 1234W FR	12Vdc, 8.5Ah	V- 0
	HRL 1234W	12Vdc, 8.5Ah	HB

Battery Manufacturer		Rating	Battery Case Flame Rating
HITACHI CHEMICAL ENERGY TECHNOLOGY CO LTD (MH14533)	HRL 1234W FR	12Vdc, 8.5Ah	V- 0
	HRL 1223W	12Vdc, 5.75Ah	HB
	HRL 1223W FR	12Vdc, 5.75Ah	V- 0
	HRL 1225W	12Vdc, 25W	HB
	HRL 1225W F2	12Vdc, 25W	HB
	HRL 1225W FR	12Vdc, 25W	V- 0
	HRL 1225W F2FR	12Vdc, 25W	V- 0
HITACHI CHEMICAL ENERGY TECHNOLOGY CO LTD (MH14533)	XTV 1285 F2FR	12 V dc, 8.5 Ah	V-0
	XTV 1285	12 V dc, 8.5 Ah	HB
	HRL 1234WF2	12 V dc, 8.5 Ah	HB
	HR 1232W F2	12 V dc, 32 W/cell	HB
KUNG LONG BATTERIES (MH16982)	WPS7-12	12 V dc, 7.0 Ah	HB
	WPS8-12	12 V dc, 8.0 Ah	HB
	WP1236(XXXX)	12 V dc, 9.0 Ah	HB
FUJIAN MINHUA POWER SOURCE (MH47104)	MS9-12	12 V dc, 9.0 Ah	V-0
	MS7-12	12 V dc, 7.0 Ah	V-0

