



**TAURMHL350K & TAURMHL700K  
70KW Power Module 480V  
User manual**

# Table of Contents

1. Safety .....	1
1.1 Important Safety Instructions.....	1
1.2 EMC .....	1
1.3 Installation information.....	1
1.4 Maintenance .....	2
1.5 Recycling the used battery .....	2
2. Installation.....	3
2.1 Initial Inspection.....	3
2.2 Installation Environment.....	3
2.3 Unpacking.....	4
2.4 Moving the Cabinet.....	6
2.5 Types of UPS Cabinet .....	9
2.6 Exterior .....	10
2.7 Internal Mechanisms .....	12
2.8 Control Panel.....	17
2.9 Introduction of Modules.....	18
2.10 Power Cable .....	21
2.11 Wiring .....	21
2.12 Power Module Installation .....	24
3. Operation Mode and UPS Operation .....	26
3.1 Block diagram of UPS .....	26
3.2 Operation Mode.....	28
3.3 UPS Operation.....	32
4. Control Panel and Display Description.....	42
4.1 Introduction .....	42
4.2 Screen Description .....	43
4.3 Alarm List .....	64
4.4 History Record.....	66
5. Interface and Communication .....	67
5.1 Dry Contact Port.....	67
5.2 Extra Comm. Slot.....	69
5.3 Local Communication Ports – RS232 & USB .....	69
5.4 SNMP Slot.....	69
6. Troubleshooting.....	70
7. Service .....	72
7.1 Replacement Procedures Of Power Module.....	72
7.2 Replacement Procedures Of STS Module .....	72
7.3 Replacement Procedures Of Air Filter.....	73
8. Specifications .....	74
8.1 Conformity And Standards .....	74
8.2 Environmental Characteristics.....	74
8.3 Mechanical Characteristics .....	74
8.4 Electrical Characteristics (Input Rectifier).....	75
8.5 Electrical Characteristics (Intermediate DC Circuit).....	75
8.6 Electrical Characteristics (Inverter Output).....	76
8.7 Electrical Characteristics (Bypass Mains Input) .....	76

# 1. Safety

## 1.1 Important Safety Instructions

This UPS contains LETHAL VOLTAGES. All repairs and service must be performed by AUTHORIZED SERVICE PERSONNEL ONLY. There are NO USER SERVICEABLE PARTS inside the UPS.

### WARNING:

- The UPS designed for commercial and industrial purpose, it is forbidden to apply for any life sustainment and support.
- The UPS system contains its own energy source. The output terminals may carry live voltage even when UPS is disconnected to an AC source.
- To reduce the risk of fire or electrical shock, UPS installation has to be in a controlled room where temperature and humidity are monitored. Ambient temperature must not exceed 40°C. The system is only for indoor use.
- Ensure all power is disconnected before installation or service.
- Service and maintenance should be performed by qualified personnel only.

#### Before working on this circuit

- Isolate Uninterruptible Power System (UPS)
- Then check for Hazardous Voltage between all terminals including the protective earth.



#### Risk of Voltage Backfeed

The isolation device must be able to carry the UPS input current.

## 1.2 EMC

**WARNING:** This is a product for commercial and industrial application in the second environment - installation restrictions or additional measures may be needed to prevent disturbances.

**WARNING:** This equipment has been tested and found to comply with the limits for a Class A digital device, pursuant to part 15 of the FCC Rules. These limits are designed to provide reasonable protection against harmful interference when the equipment is operated in a commercial environment. This equipment generates, uses, and can radiate radio frequency energy and, if not installed and used in accordance with the instruction manual, may cause harmful interference to radio communications. Operation of this equipment in a residential area is likely to cause harmful interference in which case the user will be required to correct the interference at his own expense.

## 1.3 Installation information

### WARNING:

- Installation must be performed by qualified personnel only.
- The cabinets must be installed on a level floor suitable for computer or electronic equipment.
- The UPS cabinet is heavy. If unloading instructions are not closely followed, cabinet may cause serious injury.
- Do not tilt the cabinets more than 10 degree.
- Before applying electrical power to the UPS, make sure the Ground conductor is properly

installed.

- Installation and Wiring must be performed in accordance with the local electrical laws and regulations.
- The disconnection device should be chosen based on the input current and should break line conductors – three poles for three phases.

## 1.4 Maintenance

### **WARNING:**

- Only qualified service personnel should perform the battery installation.
- The following PRECAUTIONS should be observed
  - (1.) Remove watches, rings, or other metal objects.
  - (2.) Use tools with insulated handles.
  - (3.) Wear rubber gloves and boots.
  - (4.) Do not lay tools or metal parts on top of batteries or battery cabinets.
  - (5.) Disconnect the charging source prior to connecting or disconnecting terminal.
  - (6.) Check if the battery is inadvertently grounded. If it is, remove the source of grounding. Contacting with any part of the ground might result in electrical shock. The likelihood of such shock can be prevented if such grounds are removed during installation and maintenance.
- UPS is designed to supply power even when disconnected from the utility power. After disconnect the utility and DC power, authorized service personnel should attempt internal access to the UPS.
- Do not disconnect the batteries while the UPS is in Battery mode.
- Disconnect the charging source prior to connecting or disconnecting terminals.
- Batteries can result in a risk of electrical shock or burn from high short circuit current.
- When replacing batteries, use the same number of sealed, lead-acid batteries.
- Do not open or mutilate the battery. Release electrolyte is harmful to the skin and eyes, and may be toxic.

## 1.5 Recycling the used battery

### **WARNING:**

- Do not dispose of the battery in a fire. Battery may explode. Proper disposal of battery is required. Refer to your local codes for disposal requirements.
- Do not open or mutilate the battery. Released electrolyte is harmful to the skin and eyes. It may be toxic.
- Do not discard the UPS or the UPS batteries in the trash. This product contains sealed, lead-acid batteries and must be disposed properly. For more information, contact your local recycling/reuse or hazardous waste center.
- Do not discard waste electrical or electronic equipment (WEEE) in the trash. For proper disposal, contact your local recycling/reuse or hazardous waste center.

### **CAUTION :**

RISK OF EXPLOSION IF BATTERY IS REPLACED BY AN INCORRECT TYPE. DISPOSE OF USED BATTERIES ACCORDING TO THE INSTRUCTION.

## **2. Installation**

### **2.1 Initial Inspection**

1. Visually examine if there is any damage inside and outside of packages in the process of the transportation. If any damage, report it to the carrier immediately.
2. Verify the product label and confirm the consistency of the equipment.
3. If the equipment needs to be returned, carefully repack the equipment by using the originally packing material that came with.

### **2.2 Installation Environment**

1. The UPS is designed for indoor use only and should be located in a clean environment with adequate ventilation to keep the environmental parameters within the required specification.
2. Make sure that transportation routes (e.g. corridor, door gate, elevator, etc.) and installation area can accommodate and bear the weight of the UPS, the external battery cabinet and handling equipment.
3. The UPS uses forced convection cooling by internal fans. Cooling air enters the module through ventilation grills located at the front of the cabinet and exhausted through grills located in the rear part of the cabinet. Please do not block the ventilation holes.
4. Ensure that the installation area is spacious for maintenance and ventilation.
5. Keep the temperature of installation area below 40°C and humidity within 90%. The highest operating altitude is 1000 meters above sea level.
6. If necessary, install a system of room extractor fans to avoid formation of room temperature. Air filters are necessary if the UPS is operated in a dusty environment.
7. It is recommended that you parallel the external battery cabinets to the UPS. The following instructions of clearances are suggested:
  - Keep a clearance of 100cm from the top of the UPS for maintenance, wiring and ventilation.
  - Keep a clearance of 100cm from the back of the UPS and the external battery cabinets for ventilation.
  - Keep a clearance of 150cm from the front of the UPS and the external battery cabinets for maintenance and ventilation.
8. For safety concerns, we suggest that you shall:
  - Equip with CO2 or dry powder fire extinguishers near the installation area.
  - Install the UPS in an area where the walls, floors and ceilings were constructed by fireproof materials.
9. Do not allow unauthorized personnel to enter the installation area. Assign specific personnel to keep the UPS key.

## 2.3 Unpacking

1. Use a forklift to move the product to installed area. Refer to Figure 2-1. Please make sure the bearing capacity of forklift is sufficient.
2. Please follow the orders in Figure 2-2 to remove carton and foams.

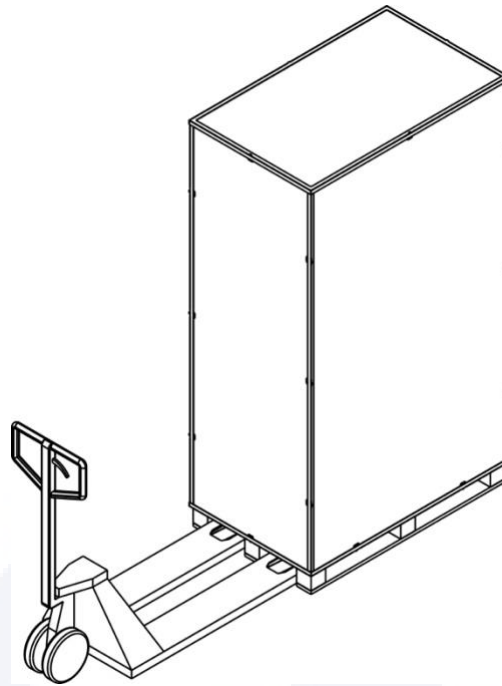

Figure 2-1

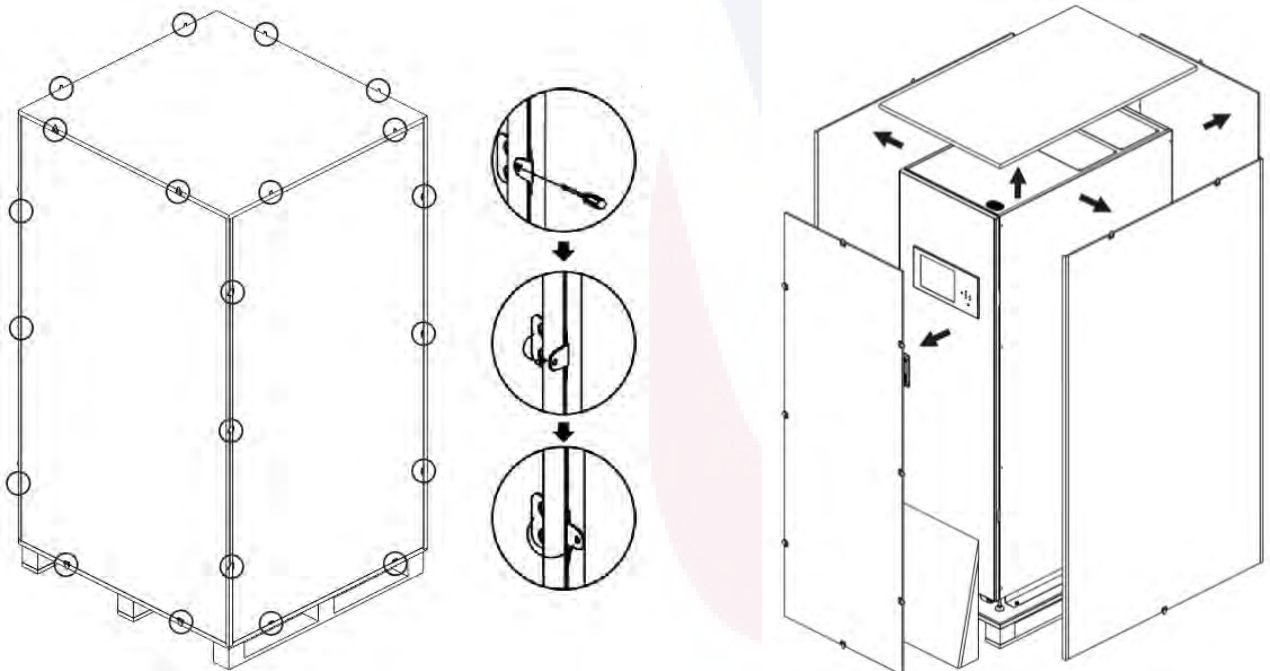

Figure 2-2

- Put a ramp in the front of the cabinet. Refer to Figure 2-3.

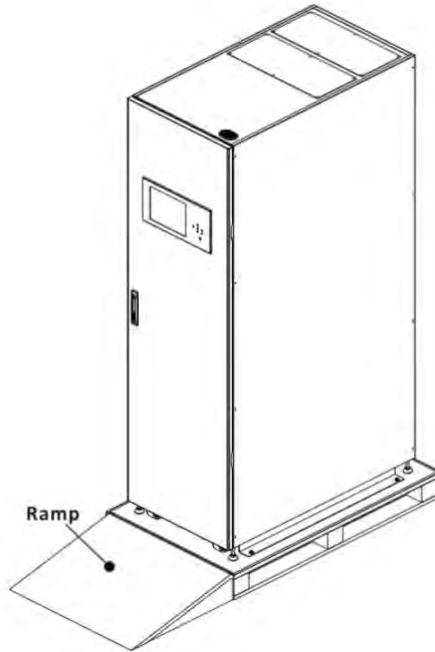

Figure 2-3

- Remove 2 fixing cabinet plates and loosen leveling feet by rotating them counterclockwise. Then, move the cabinet from the pallet. Refer to Figure 2-4.
- To fix the cabinet in position, simply rotate leveling feet clockwise. Refer to Figure 2-5.

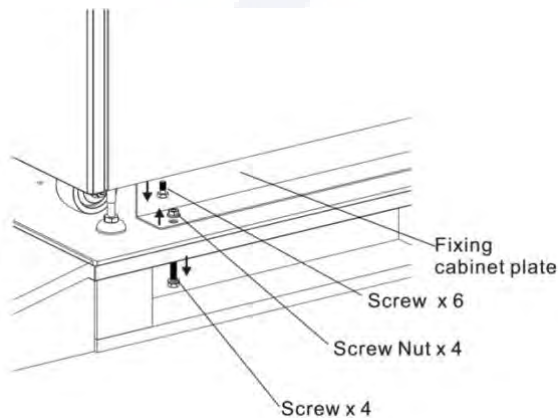

Figure 2-4

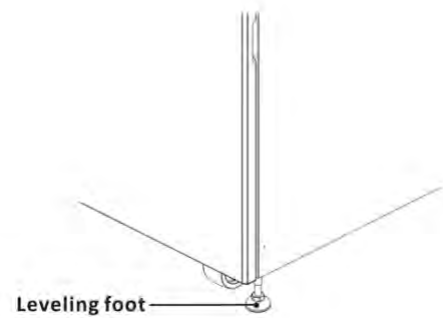

Figure 2-5

## 2.4 Moving the Cabinet

### Warning

The UPS is fixed on the pallet with 2 fixing cabinet plates. When removing it, pay attention to the movement of the casters to avoid accidents.

The cabinet can be pushed forward or backward only. Pushing it sideward is not allowed. When pushing the cabinet, pay attention not to overturn it as the gravity center is high.

1. If you need to move the UPS over a long distance, please use appropriate equipment like a forklift. Do not use the UPS casters to move over a long distance.
2. After the UPS has been removed from the pallet to ground, we suggest that at least three people move the UPS to the installation area. One person holds a lateral side of the UPS with hands, another holds the other lateral side of the UPS with hands, and the other person pushes the UPS either from the front side or from the back side to the installation area and avoid tipping the UPS.
3. The casters are designed to move on level ground. Do not move the UPS on an uneven surface. This might cause damage to the casters. Toppling the UPS could also damage the unit.
4. Ensure that the weight of UPS is within the designated bearing capacity of any handling equipment.
5. At the bottom of the UPS, the four casters help you to move the UPS to a designated area. Before you move the UPS, please turn the four leveling feet counterclockwise to raise them off the ground. This protects the leveling feet from damage when moving the UPS.
6. Fix the cabinet firmly to the ground with screwing the fixing cabinet plate. Refer to Figure 2-6.

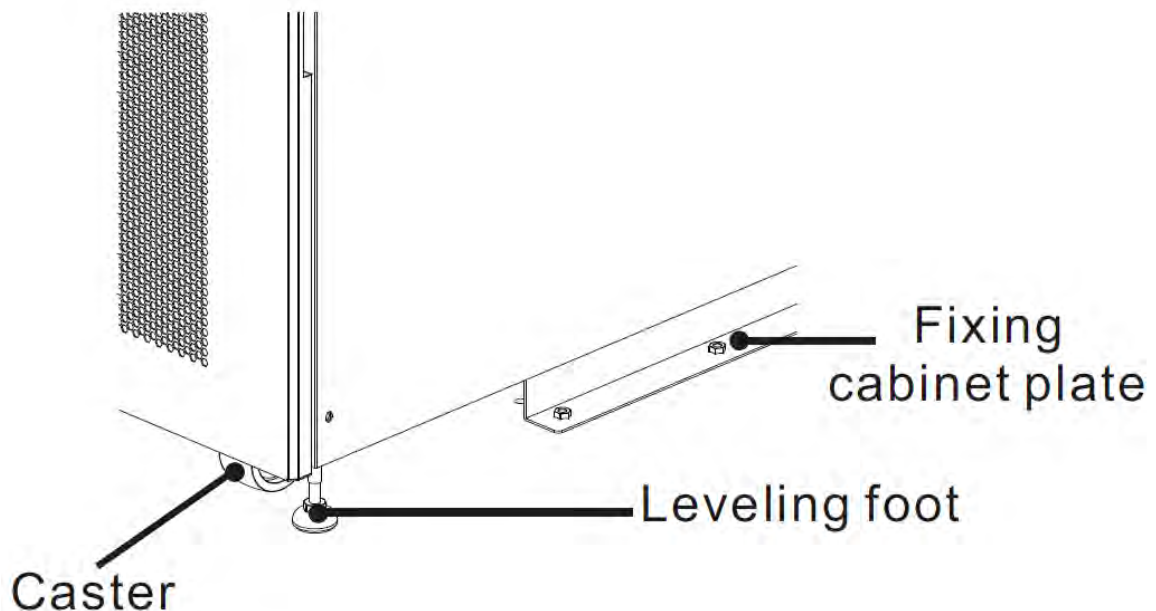
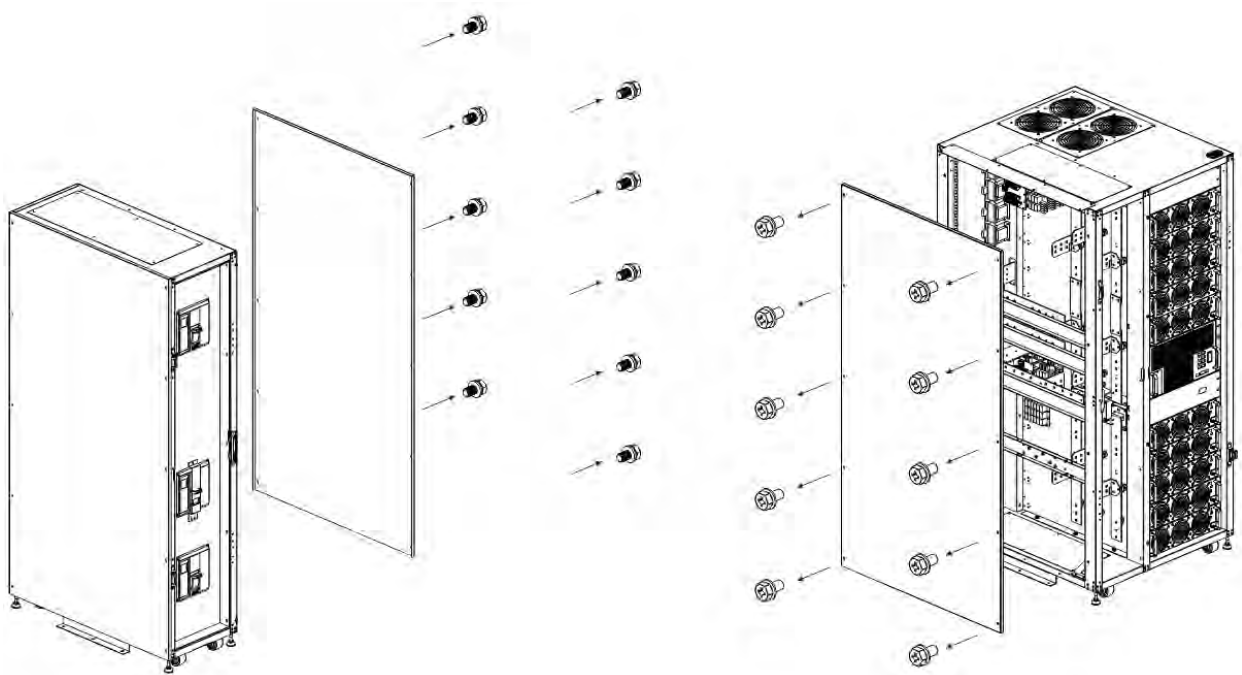

Figure 2-6



7. Assemble 42U-700 main cabinet and switch cabinet.  
Step 1: Remove one side of case cover from switch cabinet and main cabinet.



42U-700 switch cabinet  
(optional)

42U-700 main cabinet

Step 2: Remove bus bars of input 1 and bypass input on main cabinet. Remove all terminal retaining plates on switch cabinet.

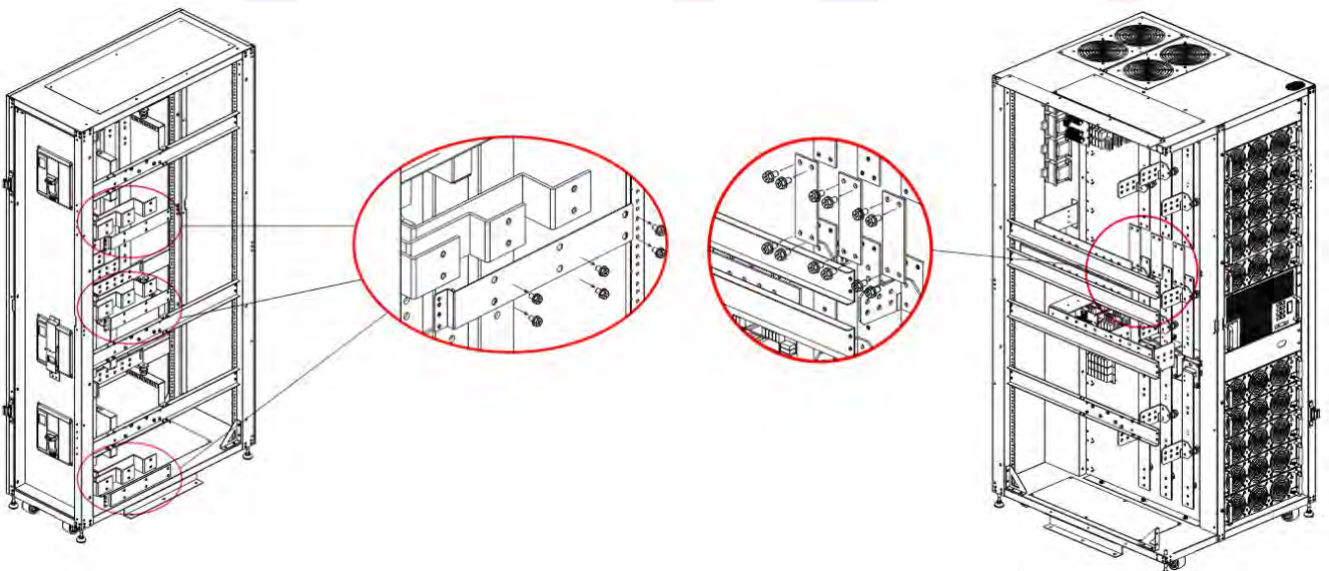

42U-700 switch cabinet  
(optional)

42U-700 main cabinet

Step 3: Align switch cabinet and main cabinet and fix both of cabinets together with supplied M10 screws, washers and spring washers. Fix long plate (supplied in switch cabinet package) on the top of two cabinets.

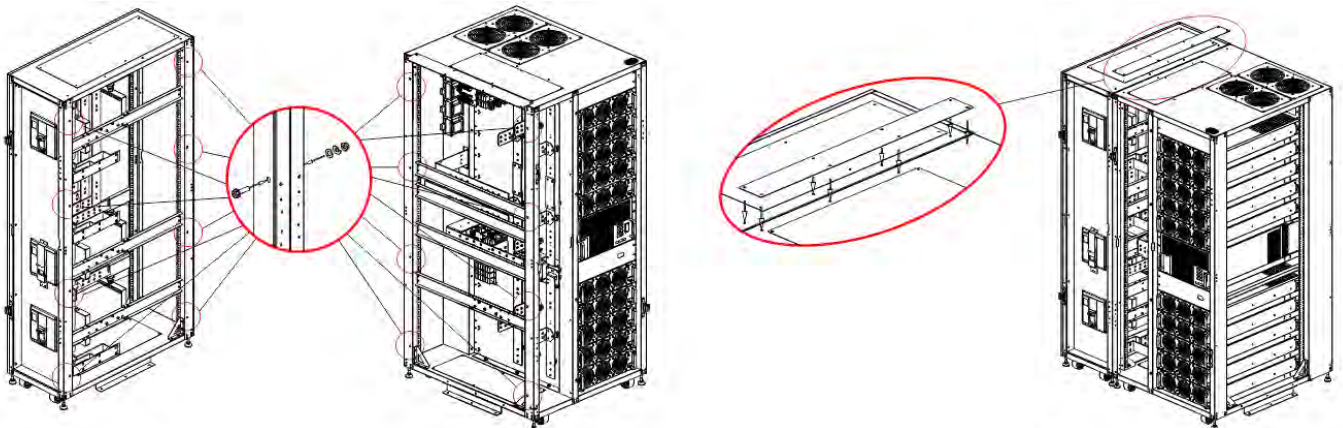

Step 4: Use supplied 9 sets of bus bars to connect input, bypass and output terminals on switch cabinet and main cabinet

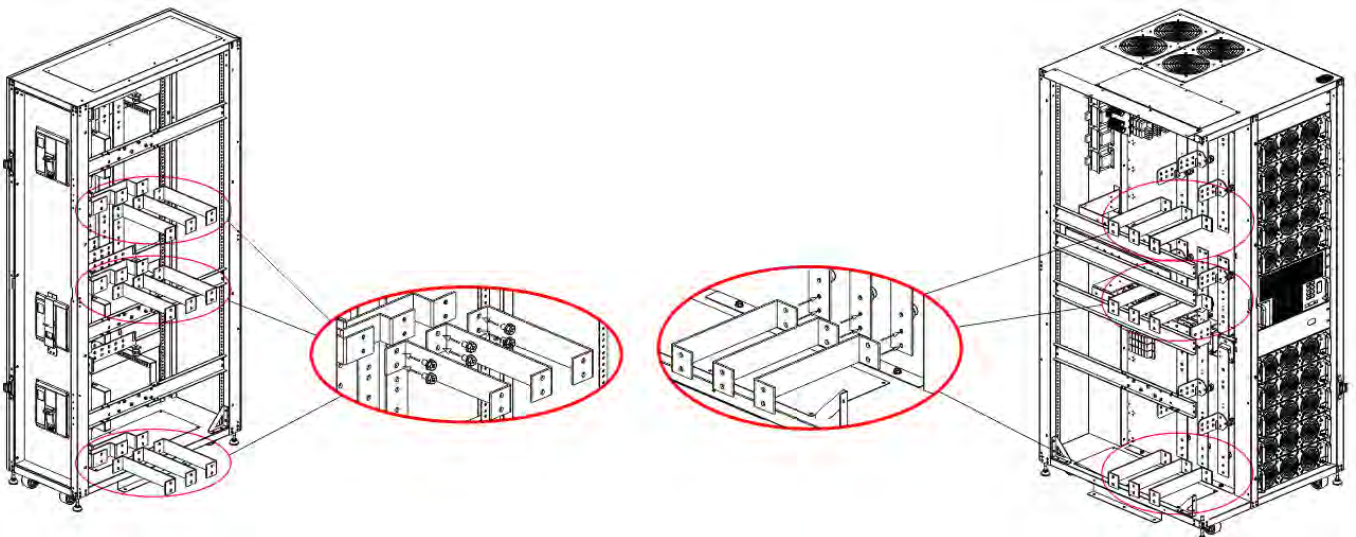

42U-700 switch cabinet  
(optional)

42U-700 main cabinet

## 2.5 Types of UPS Cabinet

The extended cabinets don't have the battery module compartments. The battery has to be

connected externally.

Please consider the external battery space and wiring gauge for installation.

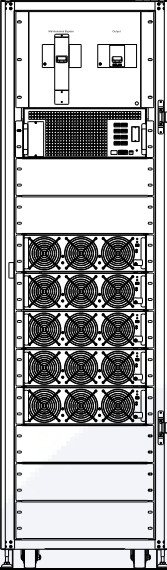
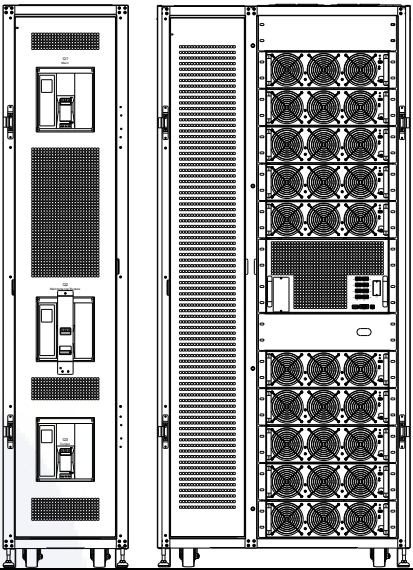
Extended Series		
Model	42U-350	42U-700
Photo		
Cabinet Height	42U	42U
Switch Unit	2	3 in one separate cabinet
STS	1	1
Max. Power Module	5	10
Max Power	350kVA	700kVA

## 2.6 Exterior

In the front of the UPS, there are control interface (LCD Panel) and door lock.

The side panels are lockable. The casters on the bottom of the UPS cabinet can be used to move over short distances. There are four leveling feet to fix and stabilize the UPS cabinet on the ground. Refer to Figure 2-7.

Inside the cabinet, there are Breakers, STS Module and Power Module slots. All wiring terminal blocks are located in the back of cabinet.

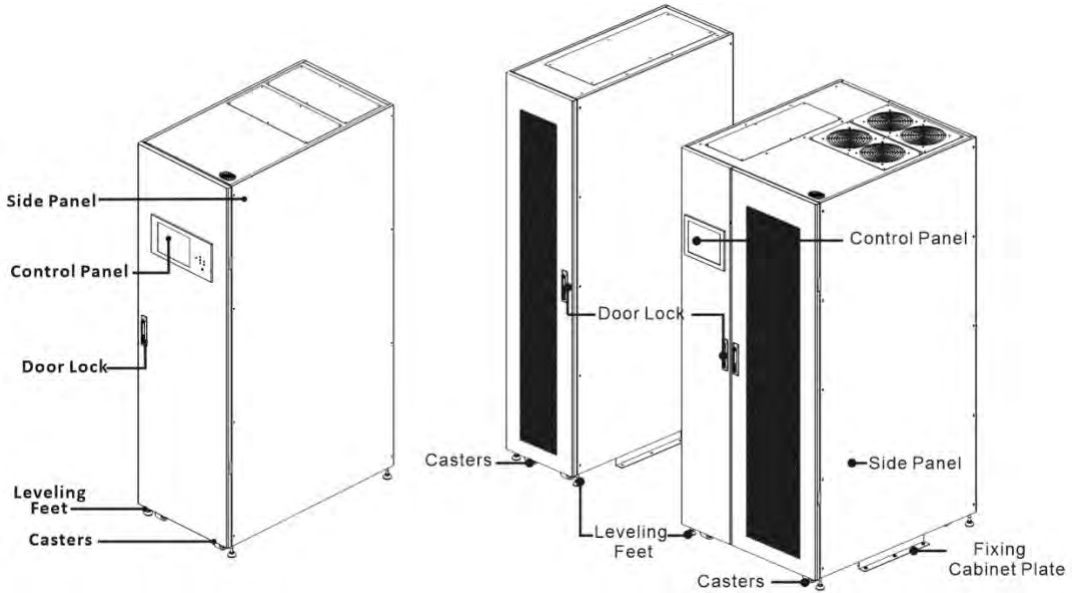

Figure 2-7

### 2.6.1 Mechanical Data

Dimensions				
UPS cabinet	Width	Depth	Height	
42U-350	600mm	1100mm	2010mm	
42U-700	UPS cabinet	900mm	1065mm	2000mm
	Switch cabinet	450mm	1065mm	2000mm

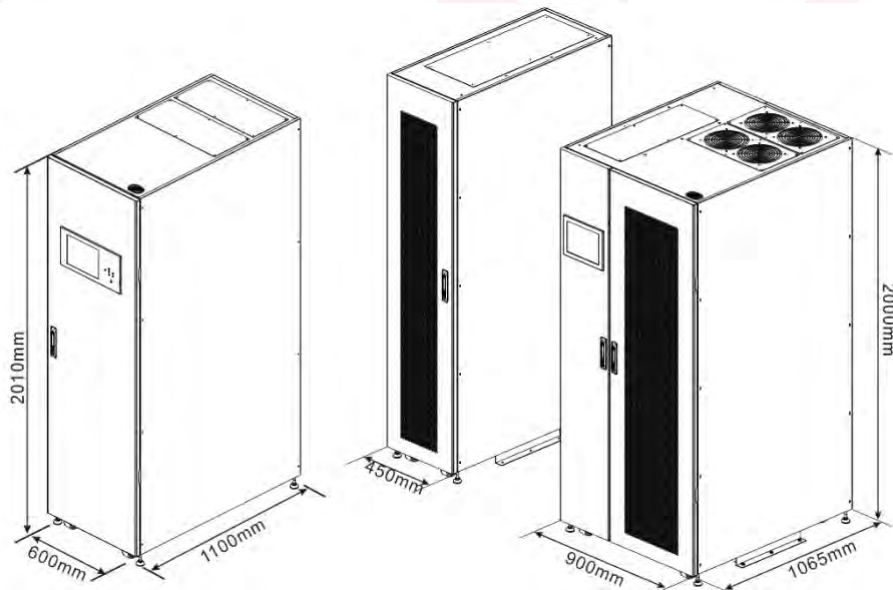

Figure 2-8 Dimensions

### 2.6.2 Front View

Unlock and open the front door and you will see the Main Breaker (Q1), Maintenance Breaker (Q2), Output Breaker (Q3), STS Module and Power Module slots. 42U-350 is equipped with maintenance

Breaker and Output Breaker.

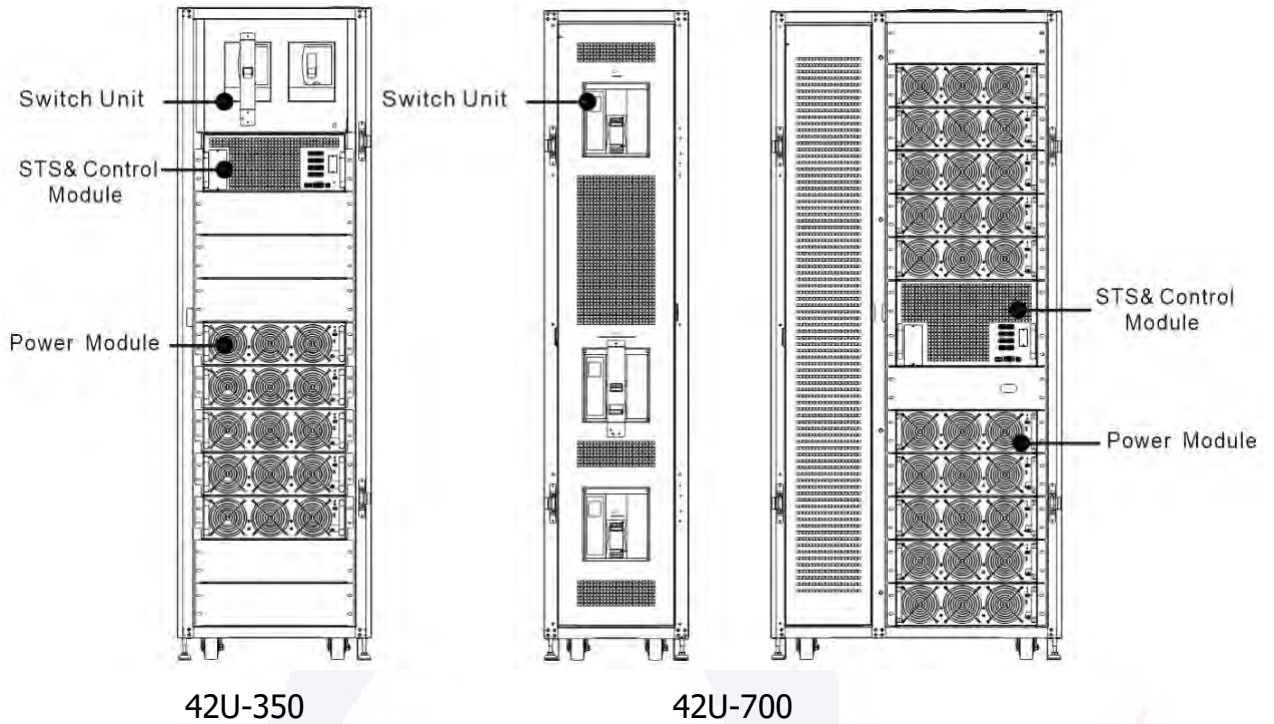

Figure 2-9 Front View

### 2.6.3 Rear View

Unlock and open the rear panel and you will see the rear of UPS.

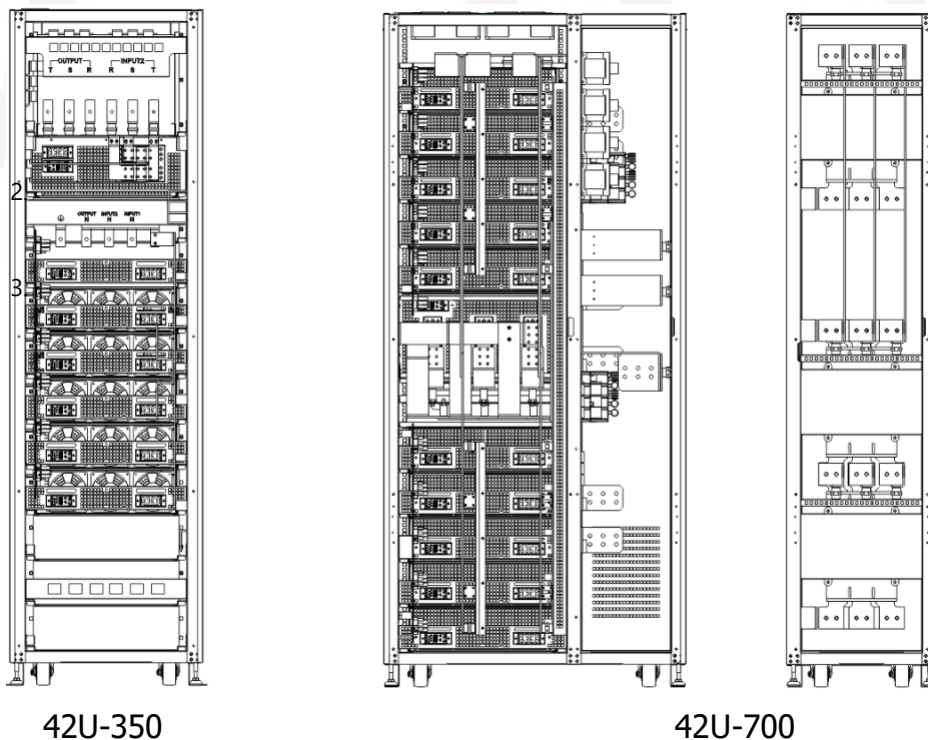

Figure 2-10 Rear View

## 2.7 Internal Mechanisms

### 2.7.1 Breakers

After opening the front door, there are three breakers, Main Breaker (Q1), Maintenance Breaker (Q2) and Output Breaker (Q3) in 350K/700K cabinet.

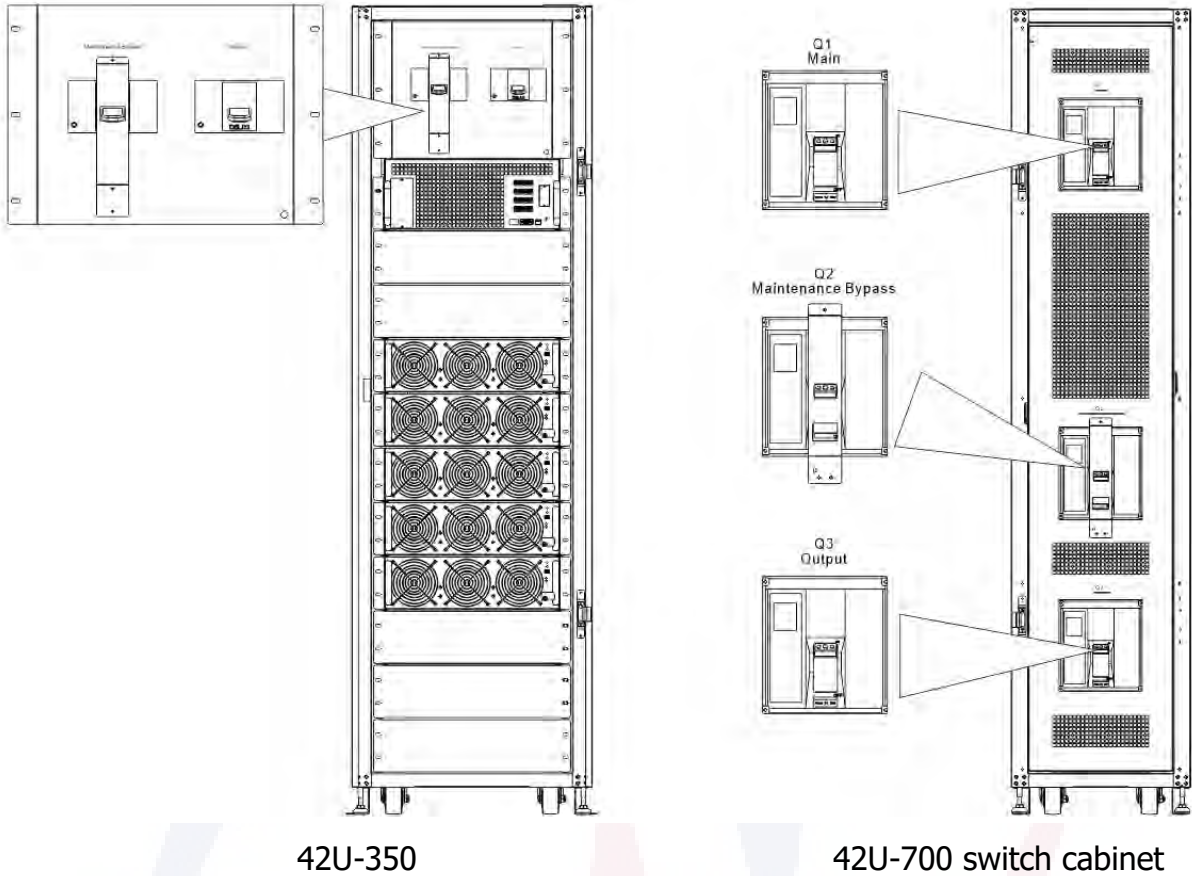
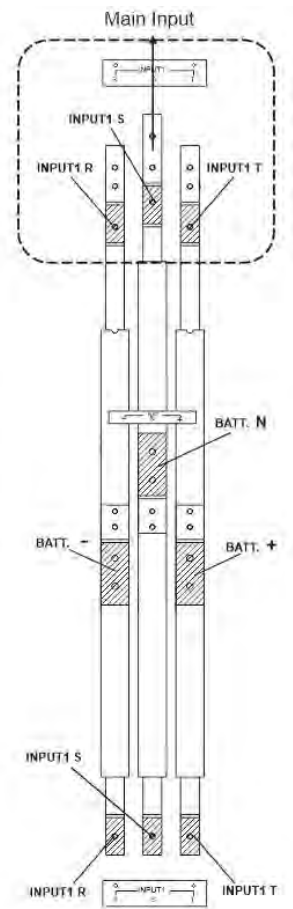
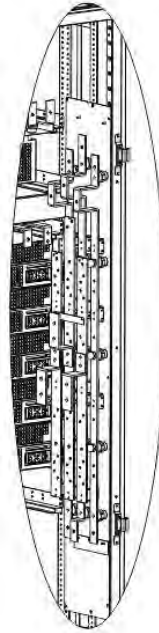
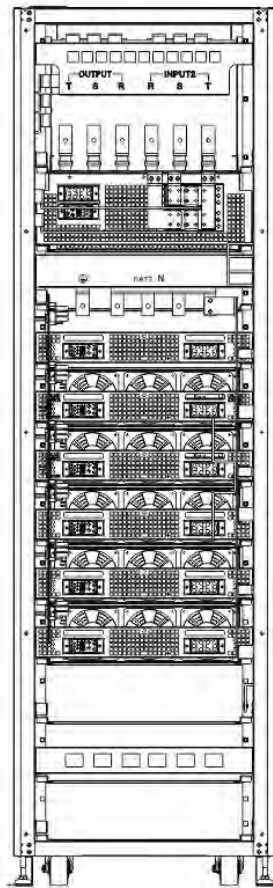
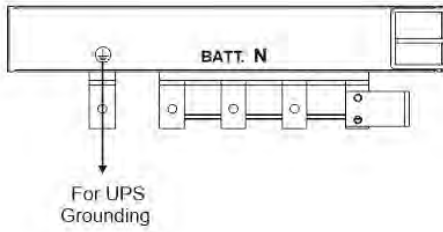
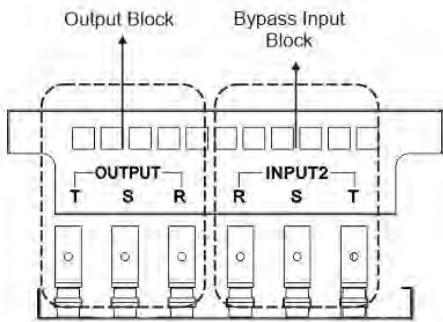

Figure 2-11 Switch (front view)

### 2.7.2 Wiring Terminal Blocks

Open the UPS's back panel and you will see the wiring terminal block. For UPS cabinet wiring, please refer to Figure 2-13.

No.	Item	Function	Description
①	Output Block	Connects the critical loads	Includes R, S, T terminals.
②	Bypass Input Block	Connects bypass AC source	Includes R, S, T terminals.
③	Main Input Block	Connects main AC source	Includes R, S, T terminals.
④	For UPS Grounding	For UPS grounding	Includes one grounding terminal.
⑤	Battery Input Block	Connects an external battery cabinet	Includes Positive (+), Negative (-) and Neutral (N) terminals.



42U-350

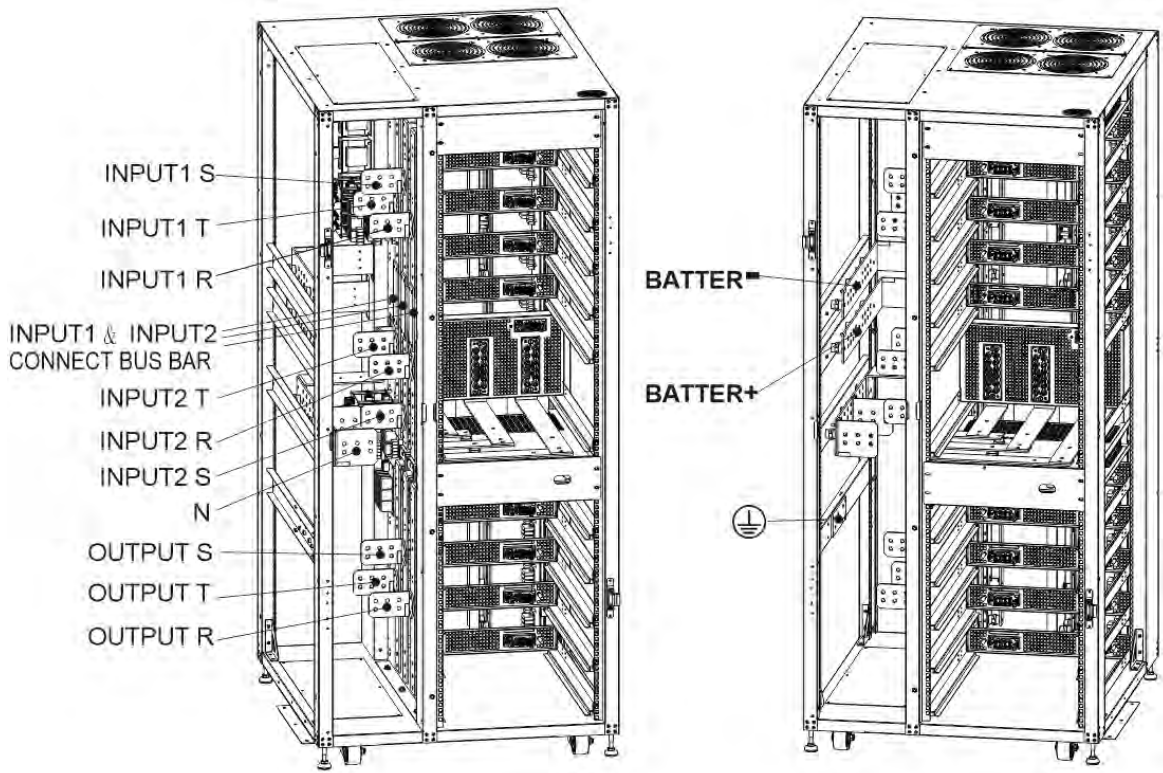

42U-700

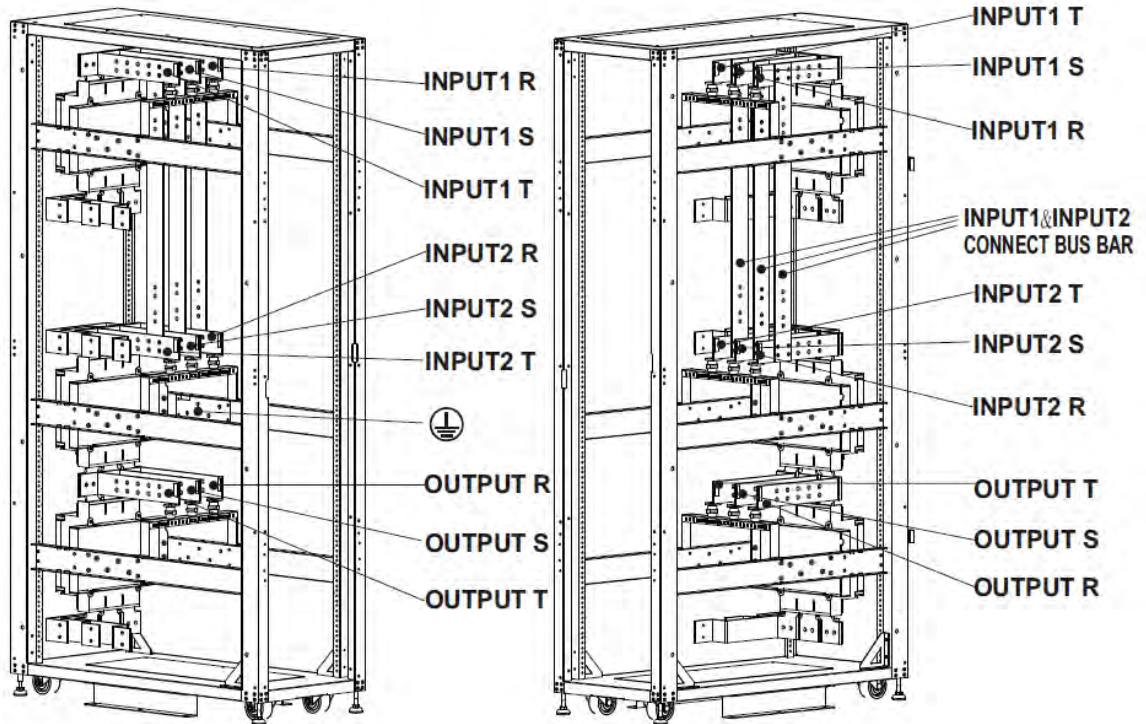

42U-700 switch cabinet

Figure 2-13 Terminal Blocks



### 2.7.3 EMI Solution

To meet EMI requirement, please add EMI core as Figure 2-14.

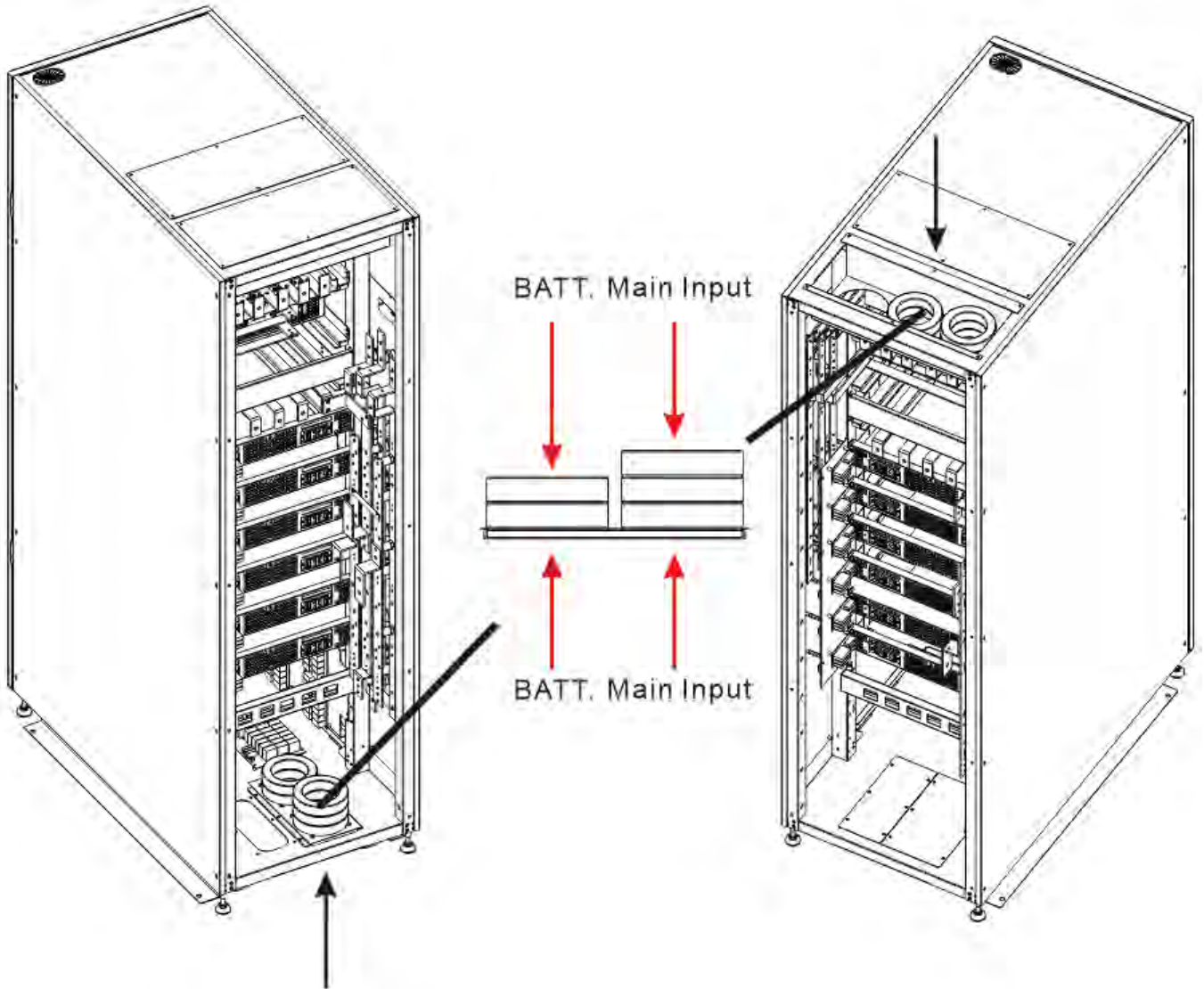

42U-350

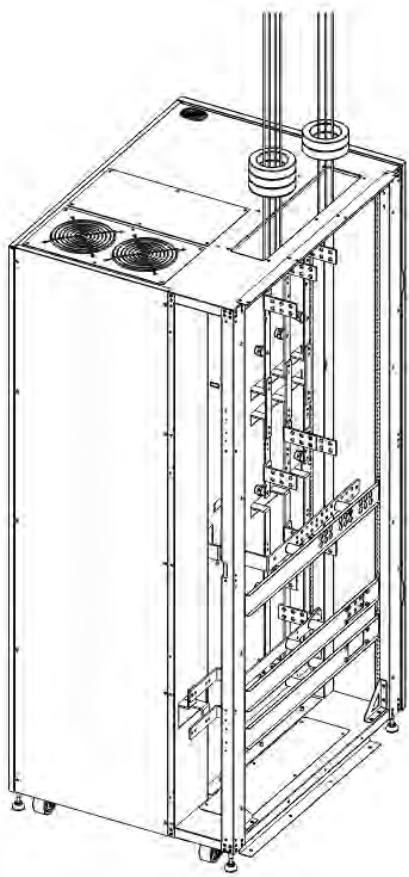

42U-700

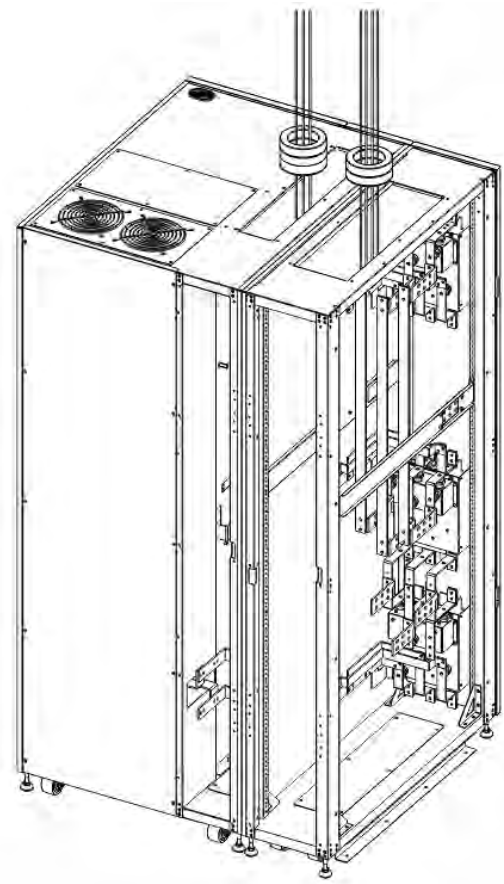
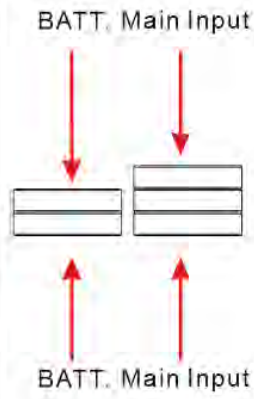

42U-700 + 42U-700 switch cabinet

Figure 2-14 EMI CORE

## 2.8 Control Panel

### 2.8.1 LCD Display

Through the touch LCD display, the user can easily understand the operation mode of UPS. In addition, the measurement, parameters, versions of firmware and warnings can be browsed in the friendly interface. For detailed information, please refer to Chapter 4.

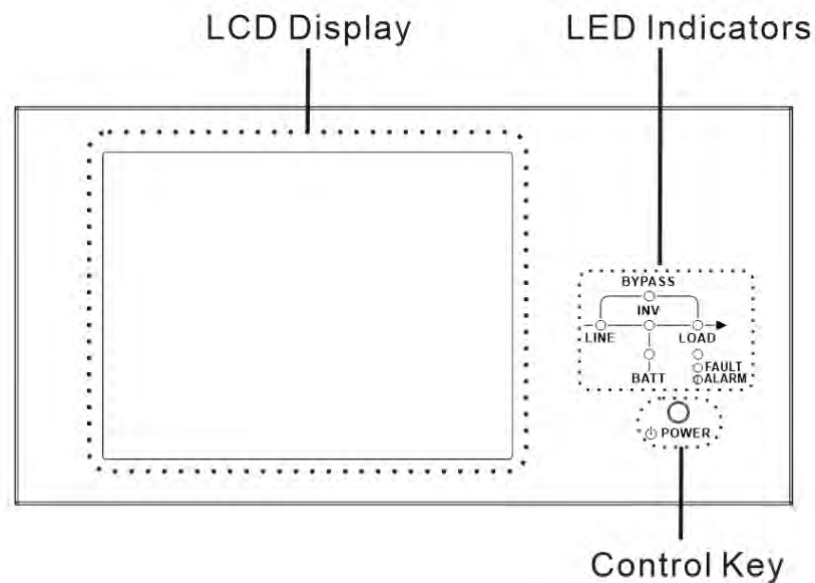

Figure 2-15 Control Panel

### 2.8.2 LED Indicators

LED	Color	Status	Definition
LINE	Green	On	Input source is normal.
		Flashing	Input source is abnormal.
		Off	No input source
BYPASS	Yellow	On	Load on Bypass.
		Flashing	Input source is abnormal.
		Off	Bypass circuit is not operating.
LOAD	Green	On	There is power output for the load.
		Off	There is no power output for the load.
INV	Green	On	Load on inverters.
		Off	Inverter circuit is not operating.
BATTERY	Red	On	Output power from Battery.
		Flashing	Low battery
		Off	Battery converter is normal and battery is charged.
FAULT/ ALARM	Red	On	UPS fault.
		Flashing	UPS alarm.
		Off	Normal.

### 2.8.3 Control Key

Turn on or turn off the UPS.

## 2.9 Introduction of Modules

The design of STS Module and Power Module make maintenance and replacement quickly and easily. The modular and hot-swappable design of Power Module makes it a highly cost-effective solution to meet your power requirement. The number of Power Modules installed in the UPS can be based on the initial needs. Once the power requirement increases, you can easily install more Power Modules without interrupting the operation of the system. Front View is shown in figure 2-9

### 2.9.1 STS Module

The STS Module is installed before leaving factory. It provides the bypass power when UPS is in Bypass Mode.

In addition to offering bypass power, it includes some communication interfaces. For detailed information, please refer to Chapter 5.

No.	Item	Description
①	Extra Comm. Slot	This slot can insert an optional card, Extra Comm. Card. This card can enhance the communication capability of UPS system and provide another SNMP slot and some dry contact ports.
②	LCD Port	This port connects to Control Panel with an installed cable from factory.
③	RS232 port	Local communication interface.
④	USB port	Local communication interface.
⑤	SNMP Slot	This slot can work with an optional card such as SNMP, AS400 or Modbus card.
⑥	Dry contact ports	CN1 ~ CN8. For detailed information, please refer to Chapter 5.

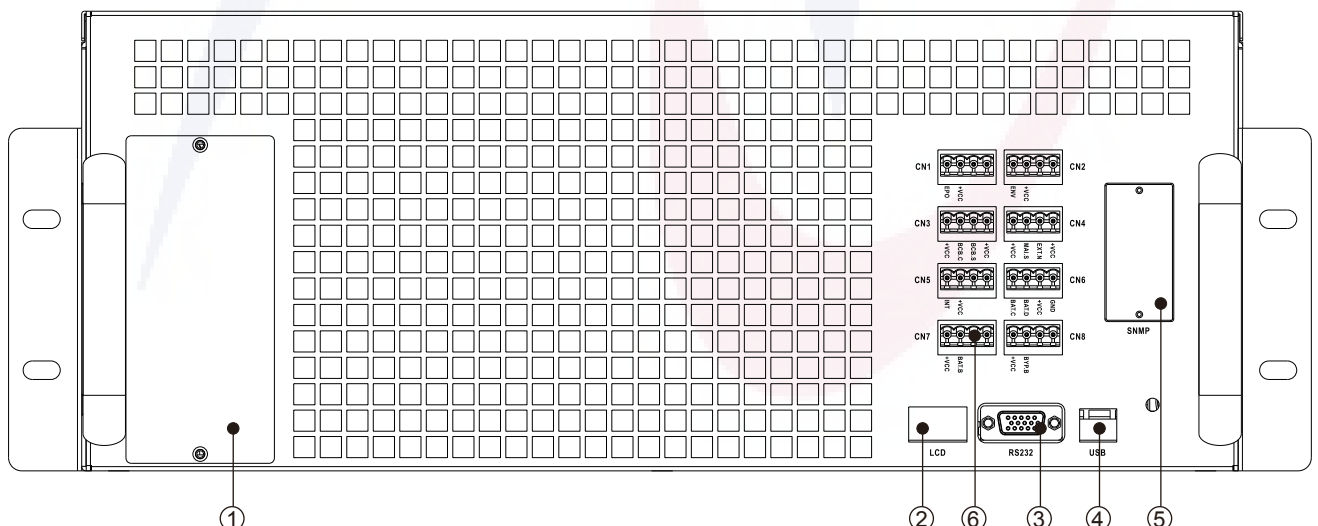

Figure 2-16 STS Module

## 2.9.2 Power Module

Each Power Module is shipped with its own package. It has to be installed during the UPS system installation.

The capacity of each Power Module is 60kVA/60kW. It includes a power factor correction rectifier, a battery charger, an inverter and control circuit.

No.	Item	Description	
①	Fan	The Power Module uses forced convection cooling by these fans. Cooling air enters the module through ventilation grills and exhausted through grills located in the rear of the module. Please do not block the ventilation area.	
②	Ready Switch	Unlock it before removing the Power Module. Lock it when the Power Module is well installed. Then the Power Module can start to work.	
③	DIP Switches	There are three DIP switches for Power Module address setting. In the same cabinet, each Power Module ID MUST be exclusive. The setting method is shown in <b>Table 2-1</b> .	
④	Battery Start Button	When AC input is not existing, use this button to start battery power for UPS.	
⑤	FAULT LED	ON	The Power Module is in fault condition or the Ready Switch is unlocked.
		ON/OFF 0.5 sec	The Power Module IDs conflict.
		ON/OFF 0.15 sec	The STS Module is not found.
⑥	RUN LED	ON	The Power Module normally works as a slave module.
		ON/OFF 0.5 sec	The Power Module normally works as a master module.
		ON/OFF 0.15 sec	CAN Bus communication failure.

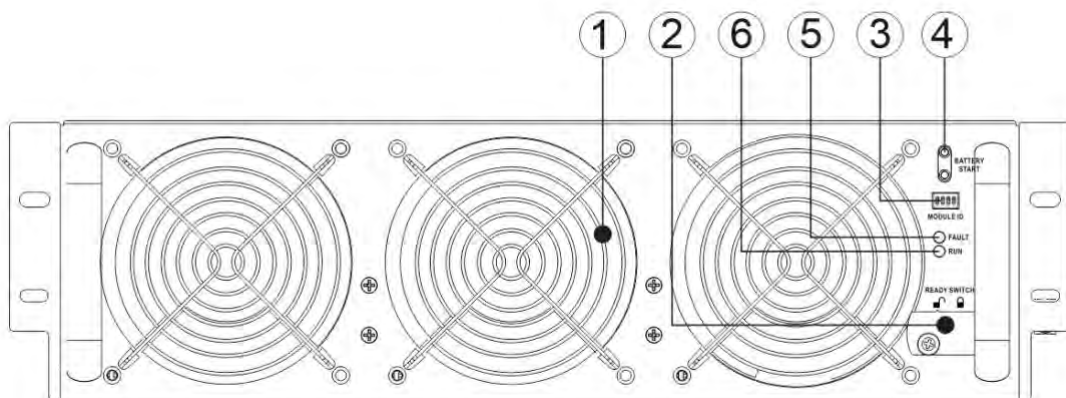

















Figure 2-17 Power Module

Module Address	DIP SWITCH	Module Address	DIP SWITCH
1		9	
2		10	
3		11	
4		12	
5		13	
6		14	
7		15	
8			

**Table 2-1** DIP switch setting and Module Address

### Power Module ID Assignment

The Power Module's ID shown in **Table 2-1**. The DIP switches (#3) are mounted in the front panel as shown in Fig 2-17.

The DIP switch position have been well set before leaving factory. It's not necessary to change it for single UPS (RACK 1) system application.

## 2.10 Power Cable

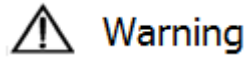

**Warning**

Please follow the local wiring regulations. Follow environmental conditions and refer to IEC60950-1.

### 2.10.1 AC input and output maximum current and power cable configuration.

Power rating	70KVA	140KVA	210KVA	280KVA	350KVA
Current (A)	110	220	330	440	550
Power cable (mm <sup>2</sup> )	35	95	240	300	150*2
Fixation torque force (lb-in)	60	60	60	60	60

Power rating	420KVA	490KVA	560KVA	630KVA	700KVA
Current (A)	660	770	916	990	1100
Power cable (mm <sup>2</sup> )	185*2	240*2	300*2	185*3	240*3
Fixation torque force (lb-in)	60	60	60	60	60

**Notice:** Installer has to consider the max current and wiring gauge when considering future extension.

### 2.10.2 DC input maximum current and power cable configuration

Power rating	70KVA	140KVA	210KVA	280KVA	350KVA
Current (A)	200	400	600	800	1000
Power cable (mm <sup>2</sup> )	95	240	150 x 2	240*2	185*3
Fixation torque force (lb-in)	60	60	60	60	60

Power rating	420KVA	490KVA	560KVA	630KVA	700KVA
Current (A)	1200	1400	1670	1800	2000
Power cable (mm <sup>2</sup> )	240*3	240*4	240x 4	300x 4	300x 4
Fixation torque force (lb-in)	60	60	60	60	60

NOTE: It is +/- 20pcs battery string

## 2.11 Wiring

### **WARNING:**

- Before connecting any wire, make sure the AC input and battery power is completely cut off.
- Make sure the breakers, Main Breaker (Q1), Maintenance Breaker (Q2), Output Breaker (Q3) and battery breaker are all in the **OFF** position.
- Make sure the Maintenance Bypass Switch is in UPS position.
- In order to have good heat dissipation, the power cables **MUST** come into the cabinet from top of the cabinet. Or the cables will block the cooling ventilation and make the over temperature failure.

### 2.11.1 Installation Drawing

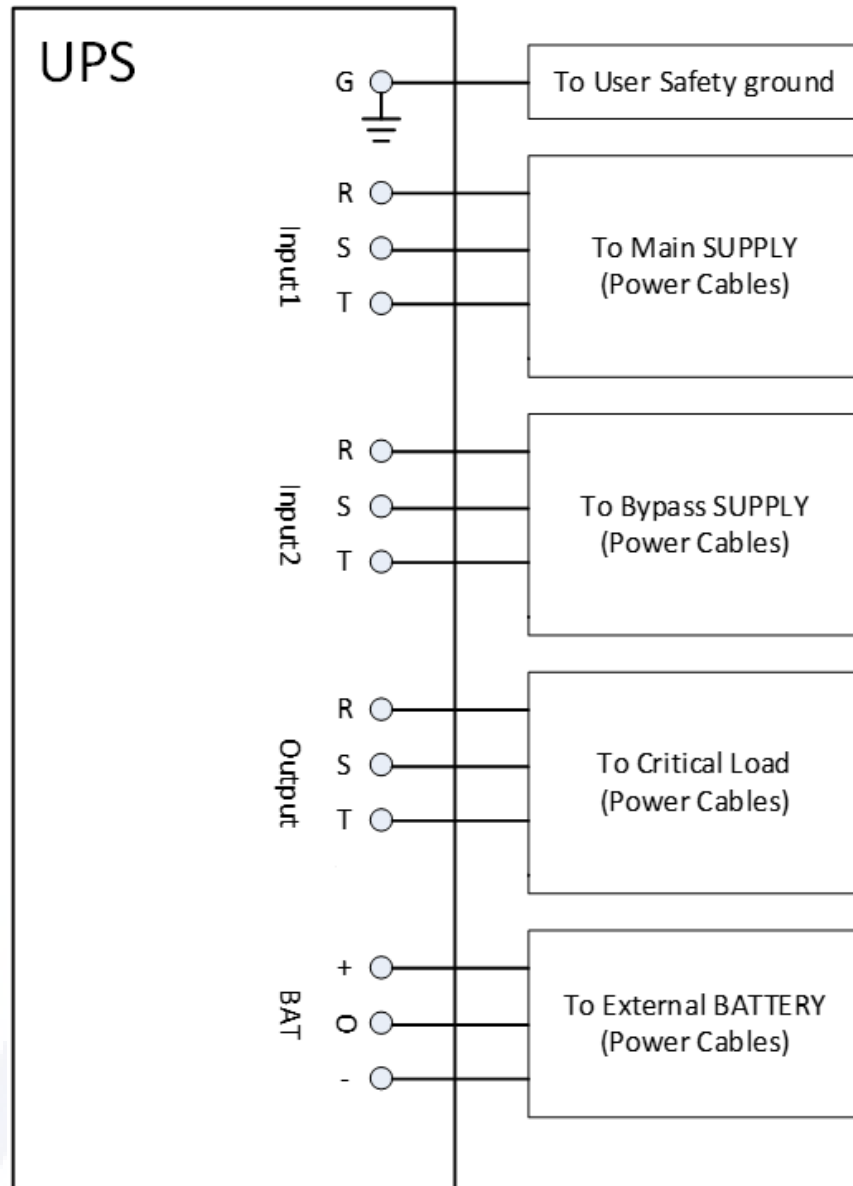

Figure 2-18 UPS Cabinet Wiring (N is not allowed to connected)

### 2.11.2 AC source connection

For **Single input** application, connect Input1 to the AC power source and use 3 short wires to connect Input1 and Input2.  
For **Dual input** application, connect Input1 to the Main AC power source and connect Input2 to the Bypass power source.

The sequence of three phase, R, S and T must be connected accordingly. The wrong sequence will alarm a warning when the UPS is powered.  
The N must NOT be connected

There is no Breaker between Input 2 and STS Module. The STS module is waked up when Input 2 is powered, although the Q1 Breaker is OFF.



### 2.11.3 External Battery Cabinet Connection

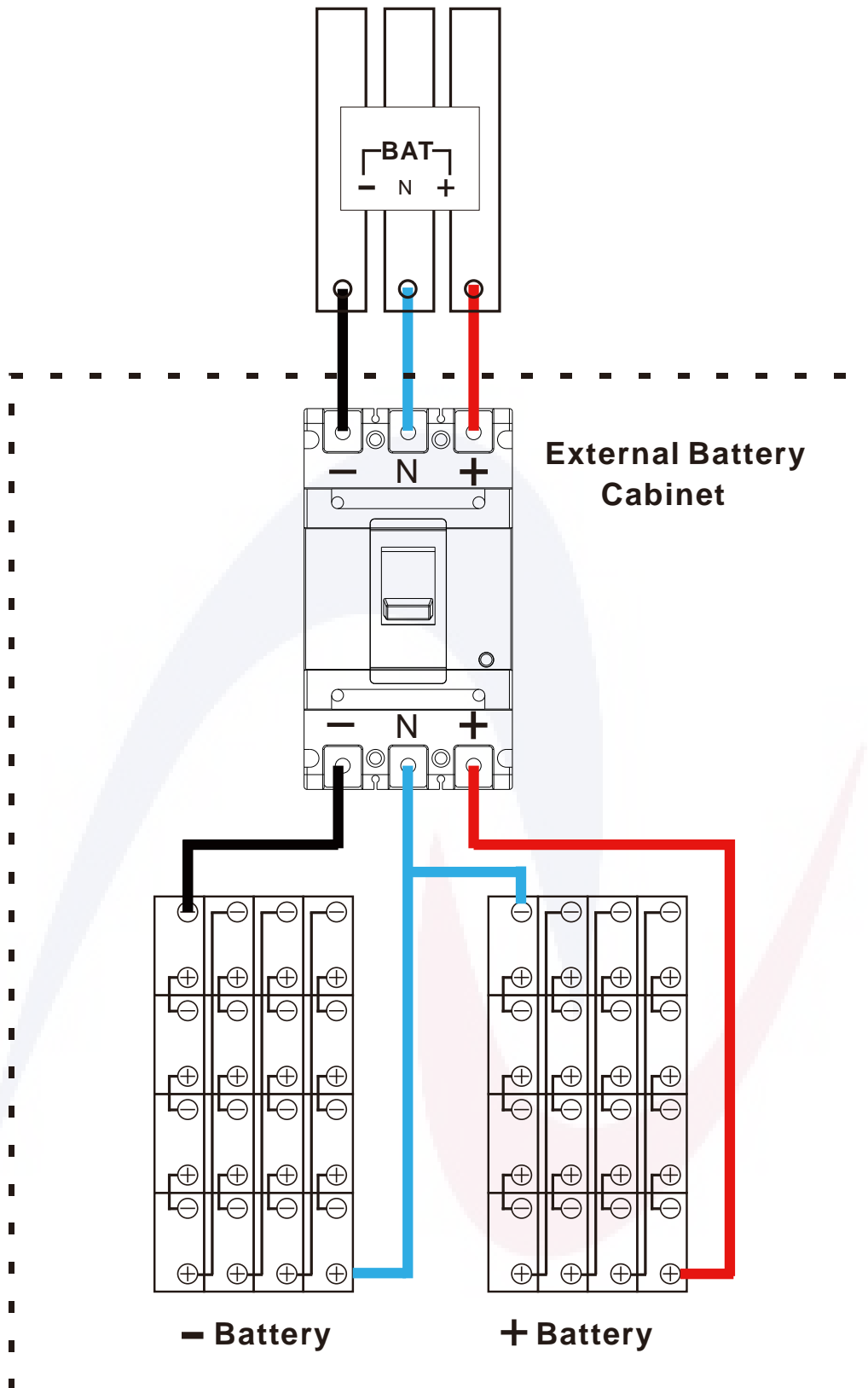

Figure 2-24 External Battery Cabinet Wiring

After the battery is completely installed, be sure to set up nominal battery voltage, battery capacity and maximum charging current in LCD setting. Otherwise, if battery setting is different from actual installation, the UPS will keep warning. Please refer to section 4.2.6.3 and **Table 4-9** for the details.

## 2.12 Power Module Installation

### Warning

The weight of Power Module is over 30Kg. Therefore, at least two persons are required for handling.

### 2.12.1 Insert the Power Module

(1.) Adjust the DIP switch positions to set the different Module Address. Refer to **Table 2-1**.

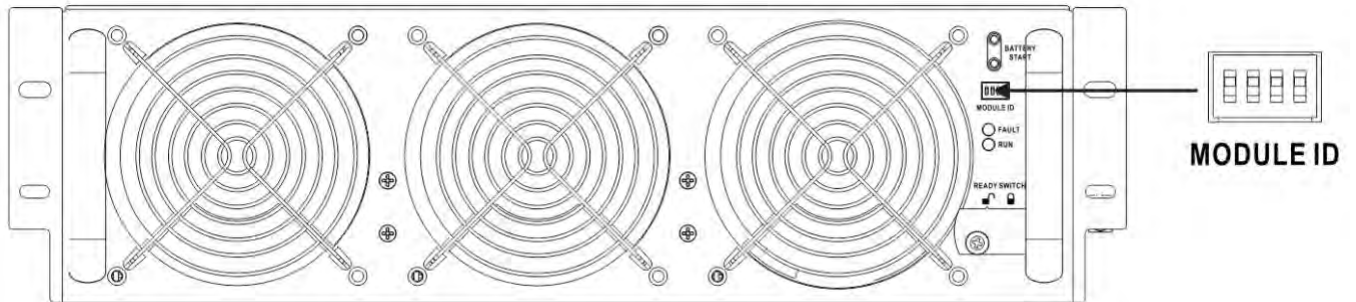

(2.) Switch the ready switch on the front panel of the module to the "■" position.

(3.) Insert the Power Module into an unoccupied slot by two persons.

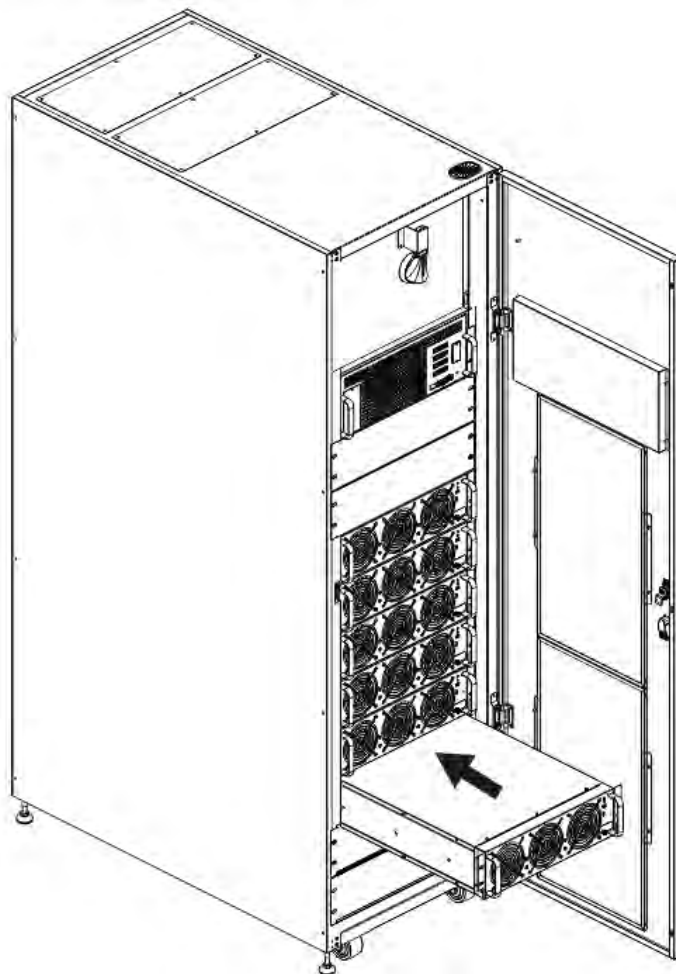

- (4.) Secure the Power Module to the cabinet by fixing the screws on the front panel of the Power Module.

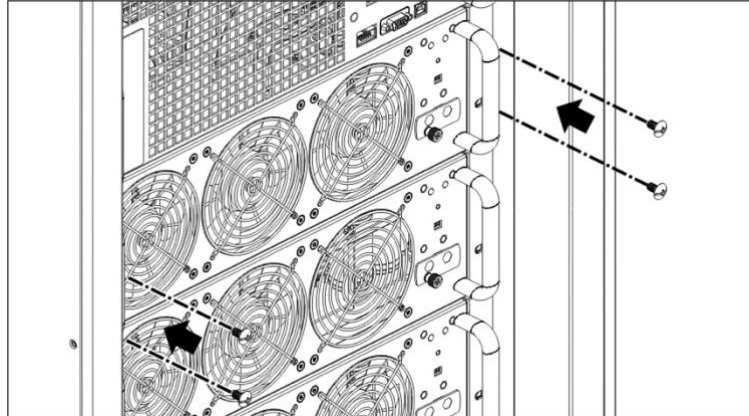

- (5.) Move the ready switch to the "🔒" position.

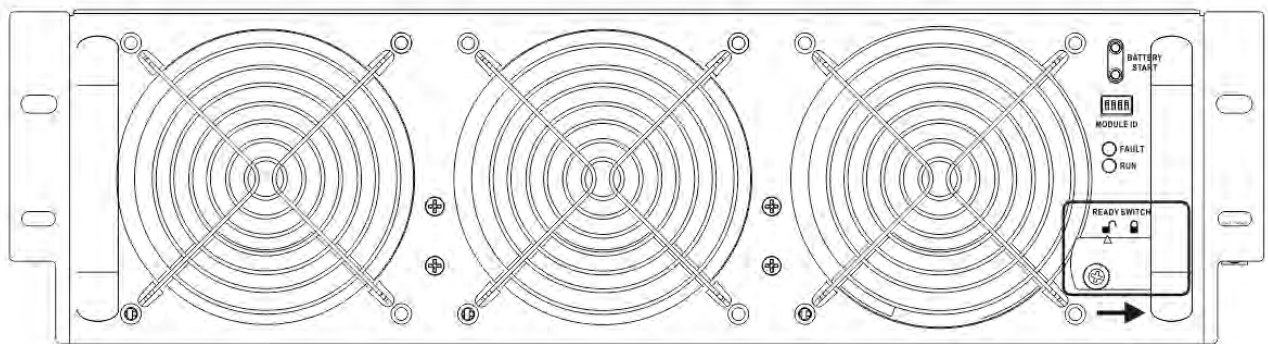

### 2.12.2 Remove the Power Module

#### ⚠ Warning

- Before removing any Power Module, make sure the remaining Power Modules can support the critical loads.
- At least one Power Module MUST stay in the UPS cabinet except the UPS system is operating in Maintenance Bypass Mode.

- (1.) Switch the ready switch to the "🔓" position.  
 (2.) FAULT LED (RED) indicator is lit to indicate the Power Module output is off and disconnected from UPS system.

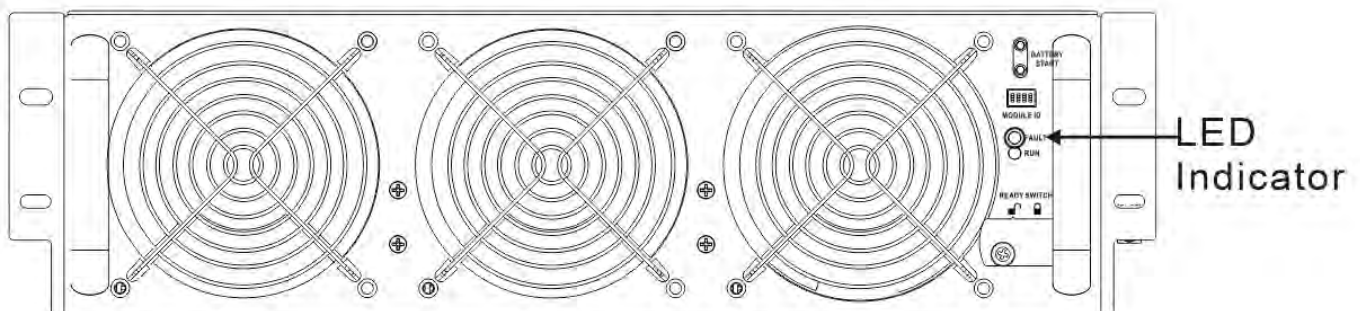

- (3.) Use a screwdriver to remove the four screws from fixing holes.  
 (4.) Two people pull out together and remove the Power Module from its slot.

### 3. Operation Mode and UPS Operation

#### 3.1 Block diagram of UPS

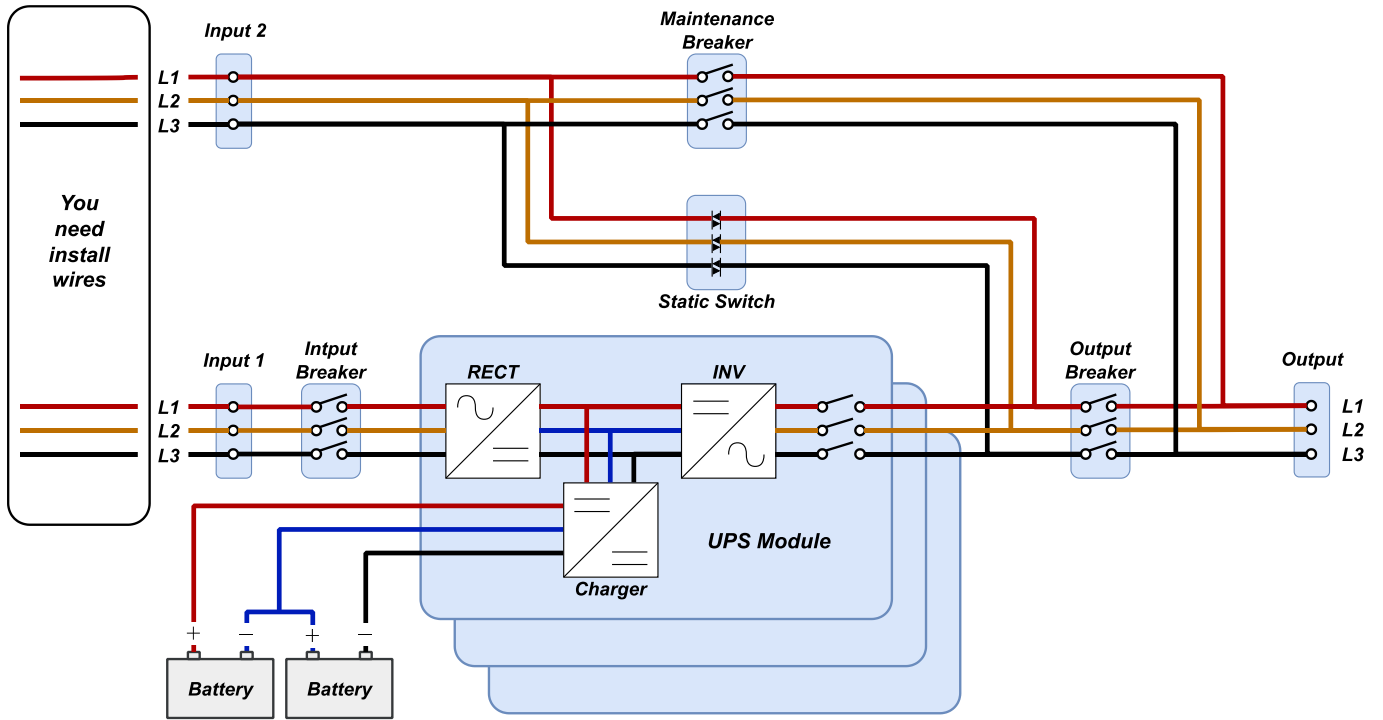

Wiring diagram for dual inputs with three breakers

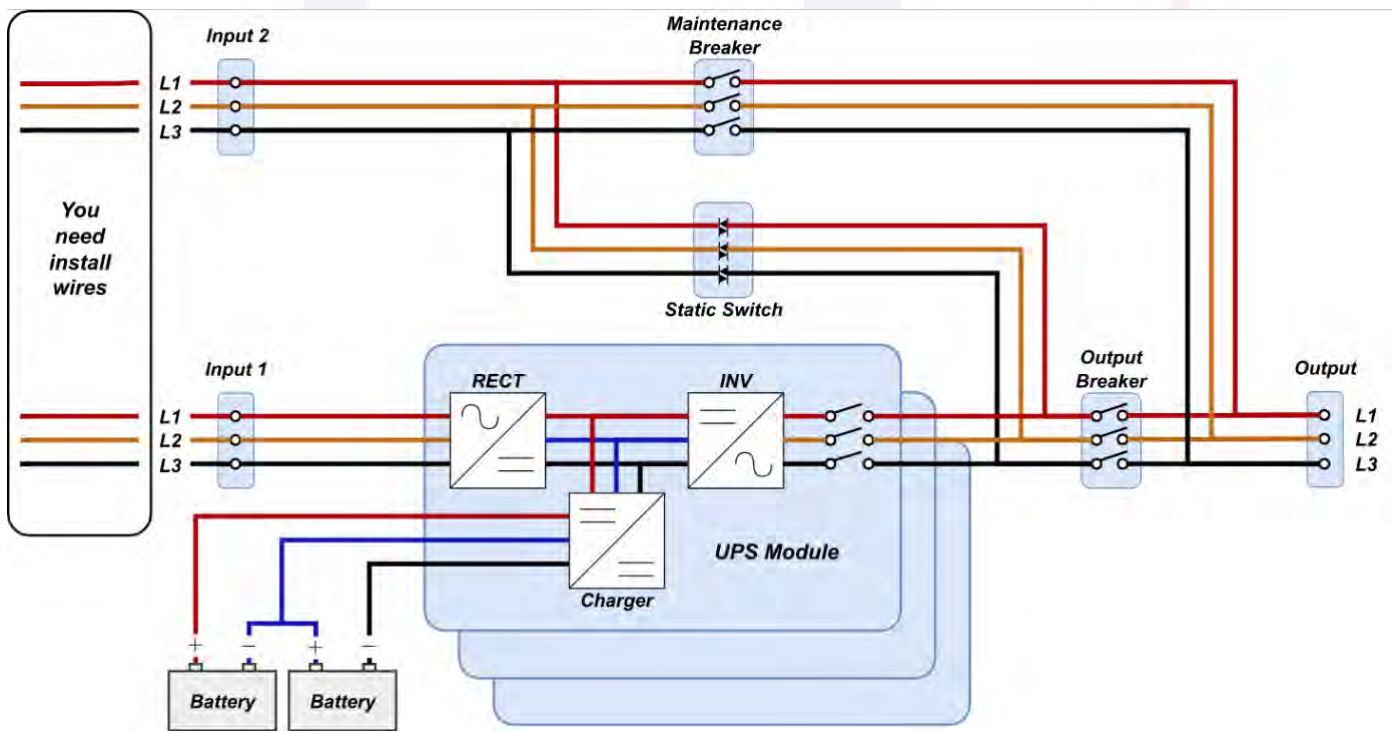

Wiring diagram for dual inputs with two breaker

Figure 3-1

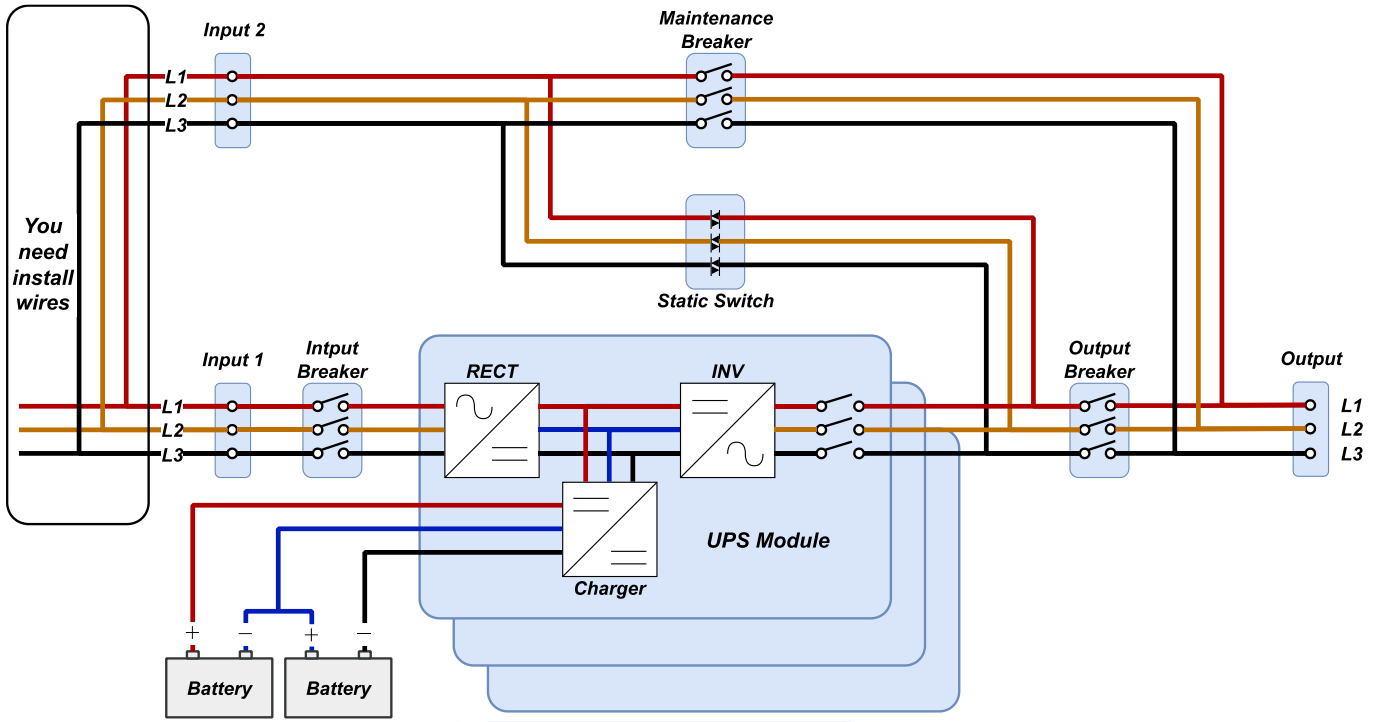

Wiring diagram for single input with three breakers

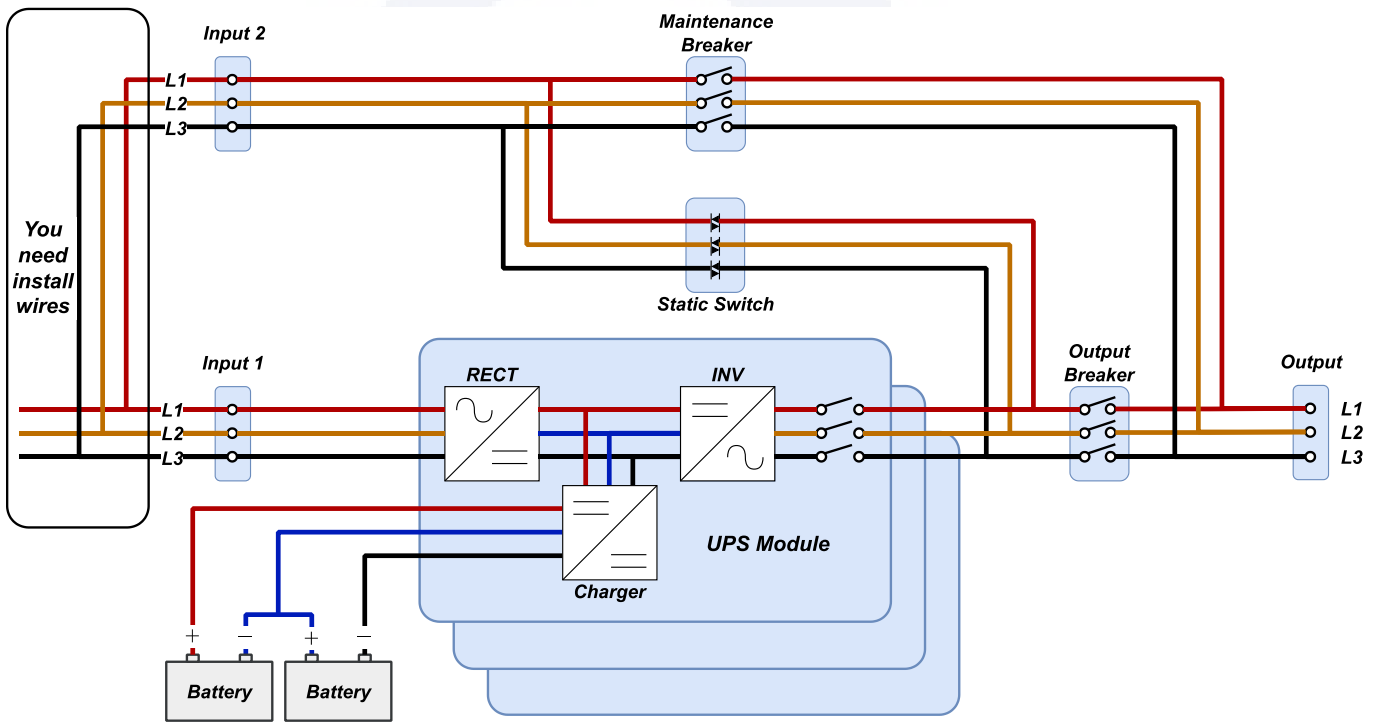

Figure 3-2 Wiring diagram for single input with two breakers

## 3.2 Operation Mode

This modular UPS is a three-phase, four wire on-line, double-conversion and reverse-transfer UPS that permits operation in the following modes:

- Standby Mode
- Line Mode
- Battery Mode
- Bypass Mode
- ECO Mode
- Shutdown Mode
- Maintenance Bypass Mode (manual bypass)

### 3.2.1 Standby Mode

Upon connecting to utility input power, the UPS is in Standby mode before UPS is turned on (if BYPASS enable setting is Disabled), and charger function will be active when the battery is present. The load is not powered under this mode.

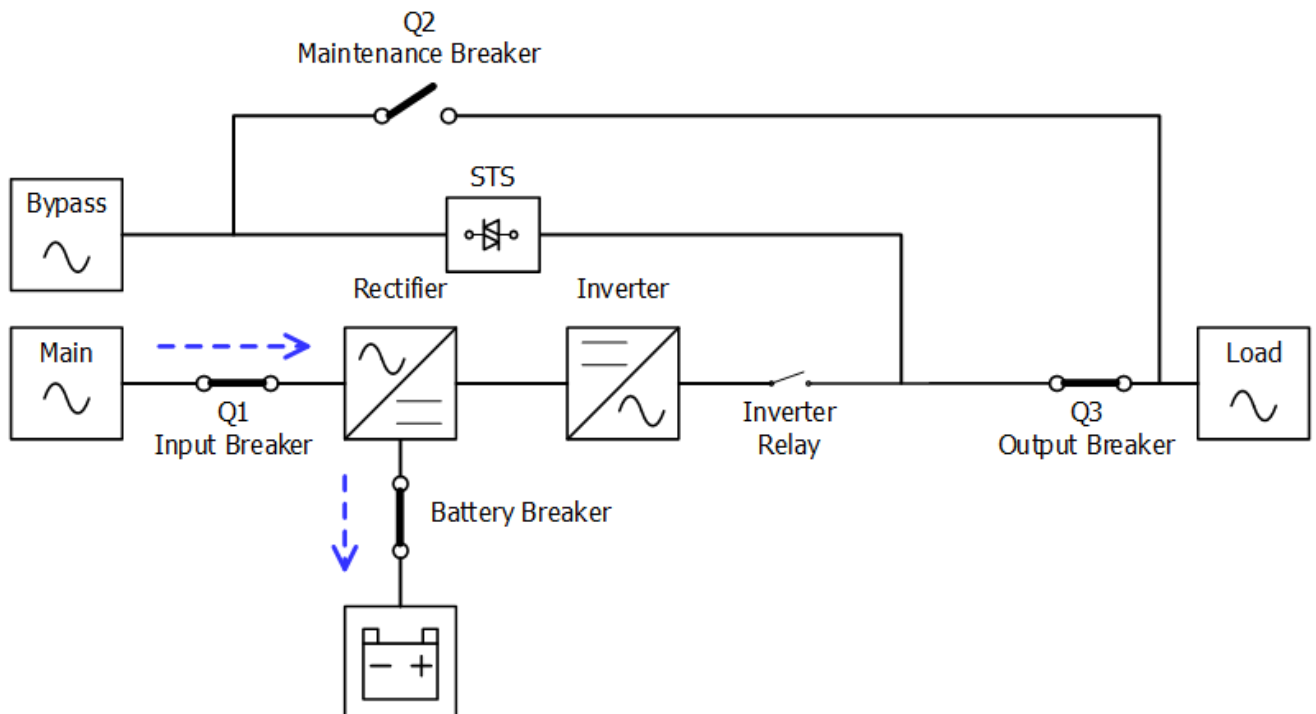

Figure 3-3 : Standby Mode Diagram

### 3.2.2 Line Mode

In Line Mode, the rectifier derives power from the utility power and supplies DC power to the inverter and the charger charges the battery. The inverter filters the DC power and converts it into pure and stable AC power to the load.

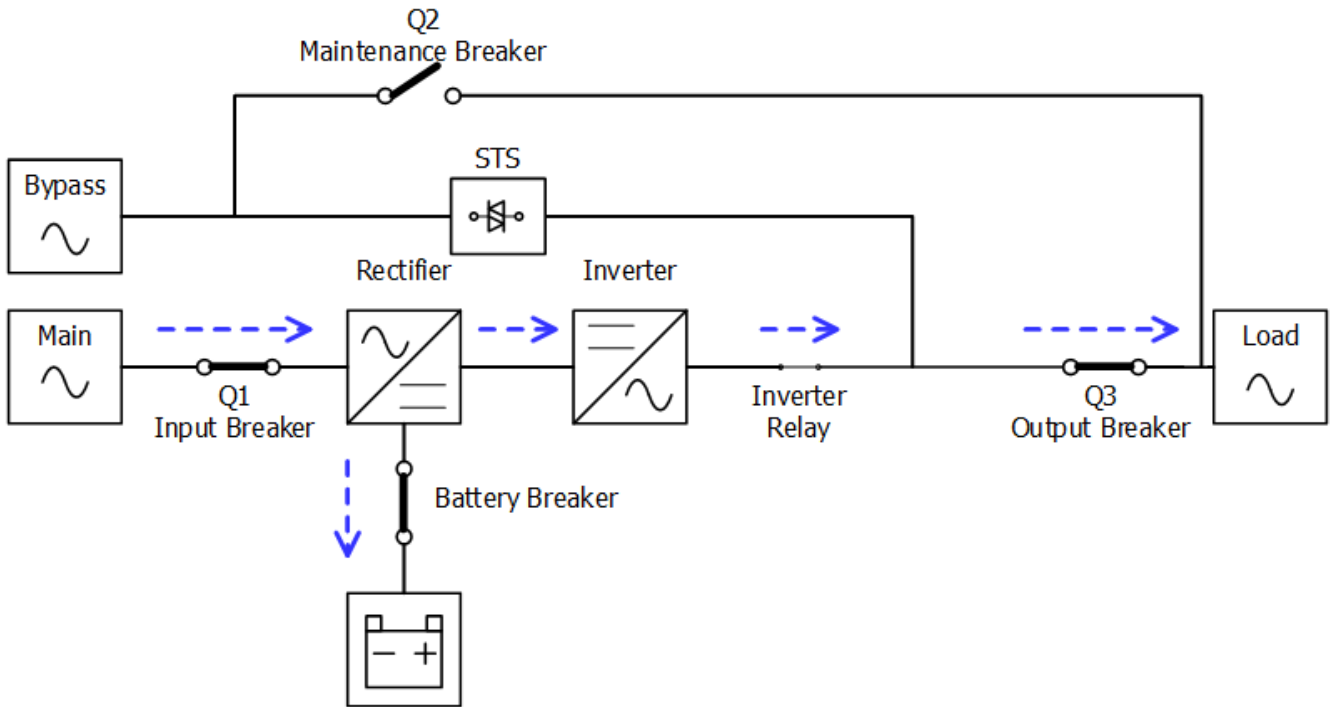

Figure 3-4 : Line Mode Diagram

### 3.2.3 Battery Mode

The UPS automatically transfers to Battery mode if the utility power fails. There is no interruption in power to the critical load upon failure.

In battery mode, the rectifier derives power from the battery and supplies DC power to the inverter. The inverter filters the DC power and converts it into pure and stable AC power to the load.

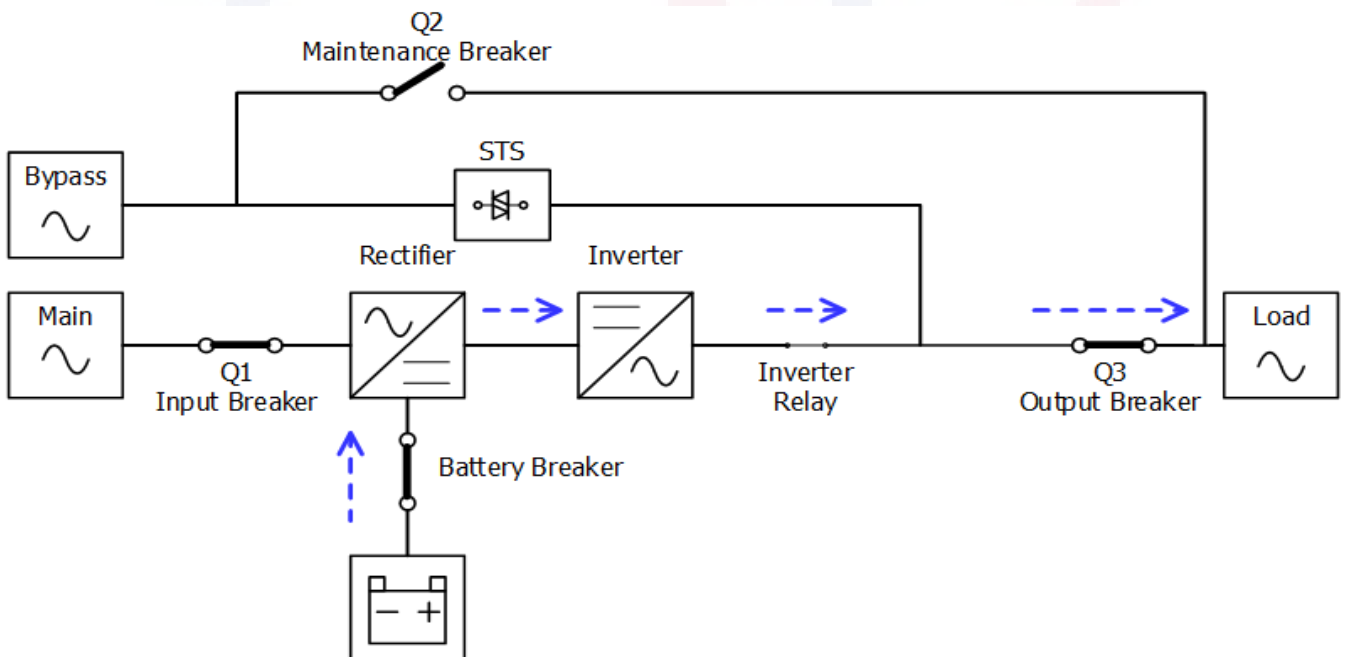

Figure 3-5 : Battery Mode Diagram

### 3.2.4 Bypass Mode

Upon connecting to utility input power, the UPS is in Bypass mode before UPS is turned on (if BYPASS enable setting is Enabled), and charger function will be active when battery is present.

After UPS has been turned on, if the UPS encounters abnormal situations (over-temperature, overload, and etc.), the static transfer switch will perform as a transference of the load from the inverter to the bypass source with no interruption. If the transference is caused by a recoverable reason, the UPS will turn back to line mode when abnormal situation is solved.

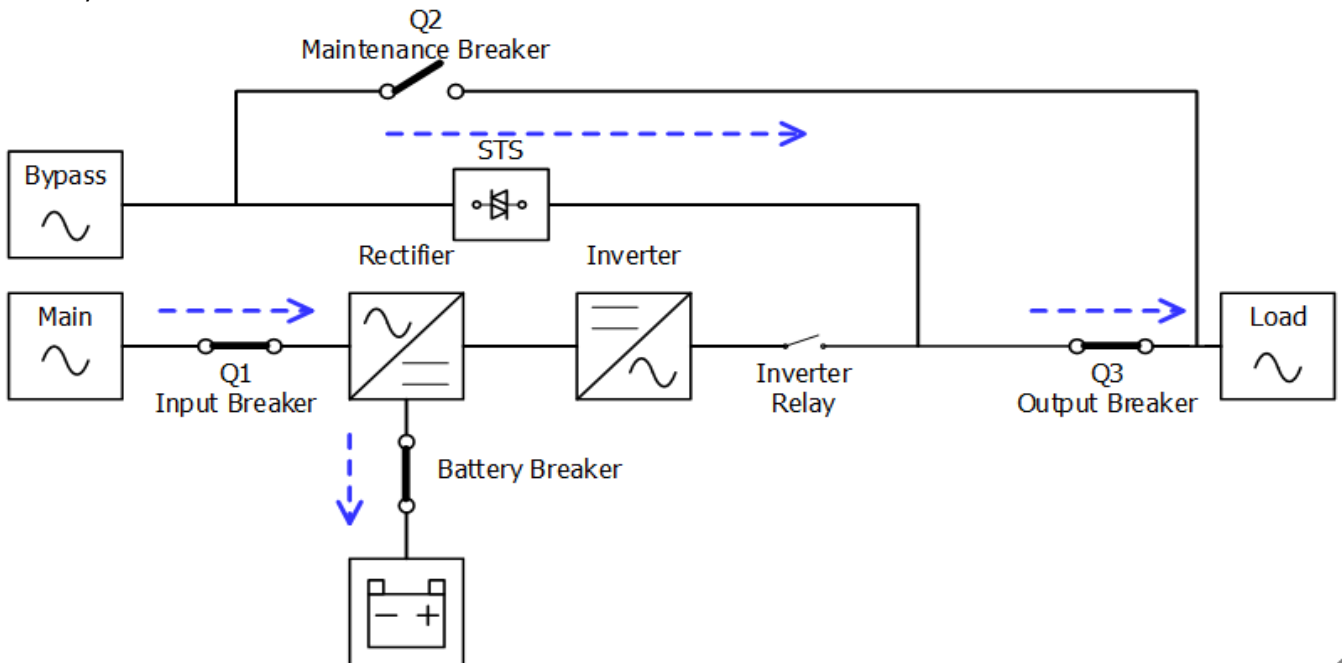

Figure 3-6 Bypass Mode Diagram

### 3.2.5 ECO Mode

The ECO Mode is enabled through the setting menu of LCD panel. In ECO mode, the load is powered by bypass when the bypass voltage and frequency are within the acceptable ranges. If the bypass is out of range, the UPS will transfer the power source of load from bypass to inverter. In order to shorten the transfer time, the rectifier and inverter are working when the UPS is in ECO mode.

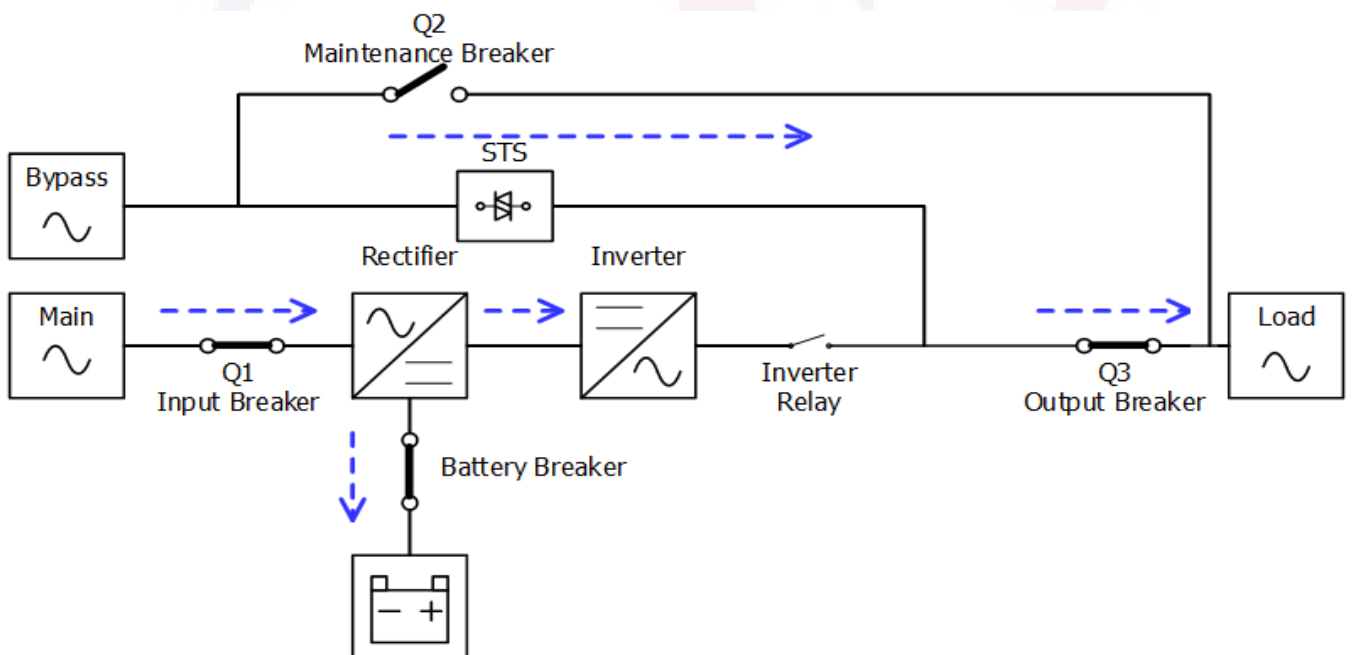

Figure 3-7 ECO Mode Diagram



### 3.2.6 Shutdown Mode

When the UPS is in the off state and the utility power source is absent, the UPS will enter into shutdown mode.

Or when the UPS has discharged the battery to the cut-off level, the UPS will enter into shutdown mode as well.

When the UPS enters this mode, it is going to shut off the control power of UPS. The rectifier, charger and inverter are all in off state.

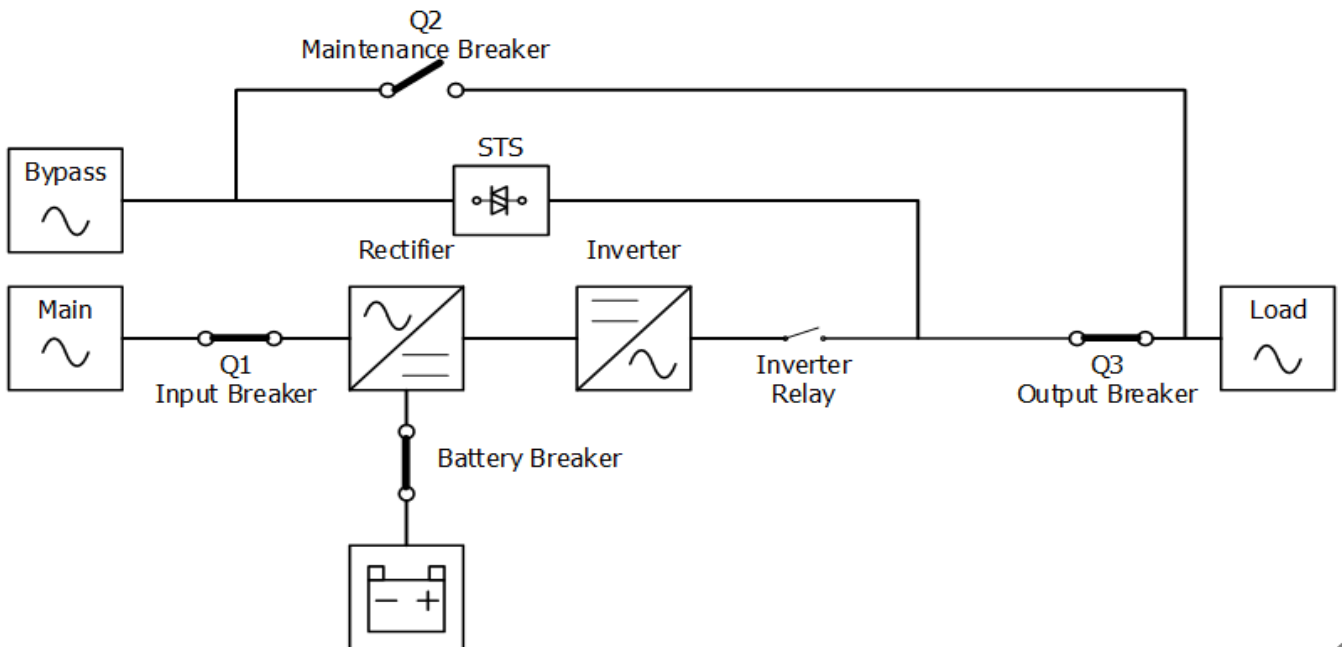

Figure 3-8 Shutdown Mode Diagram

### 3.2.7 Maintenance bypass Mode

A manual bypass switch is available to ensure continuity of supply to the critical load when the UPS becomes unavailable e.g. during a maintenance procedure. Before entering the maintenance bypass mode, make sure the bypass power source is normal.

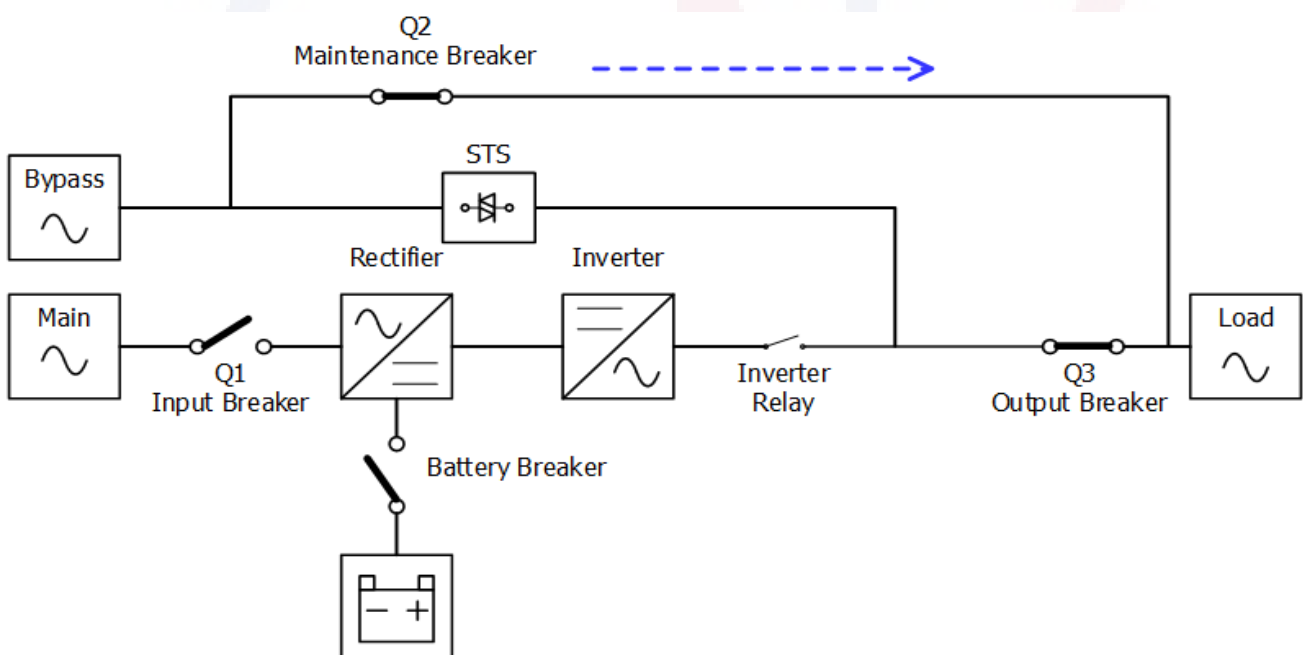

Figure 3-9 Maintenance Bypass Mode Diagram

### 3.3 UPS Operation



Warning

- Do not start the UPS until the installation is completed.
- Make sure the wiring is correct and the power cables are fixed firmly.
- Make sure the Power Modules' address have been configured. Refer to section 2.9.2 Power Module
- Make sure the ready switch on the Power Module has been switched to the "Locked" position.
- Make sure all the breakers are switch **OFF**.

#### 3.3.1 AC Startup

Ensure to follow this procedure when turning on the UPS from a fully powered-down condition.

The operating procedures are as follows:

**Step 1:** Refer to "Chapter 2 Installation" to connect the power cables and install the Power Modules and the battery required for the UPS system.

**Step 2:** Switch ON the battery breaker.

**Step 3:** Switch ON the external power switch in distribution panel to power the UPS. The STS module starts running and the LCD panel is displayed.

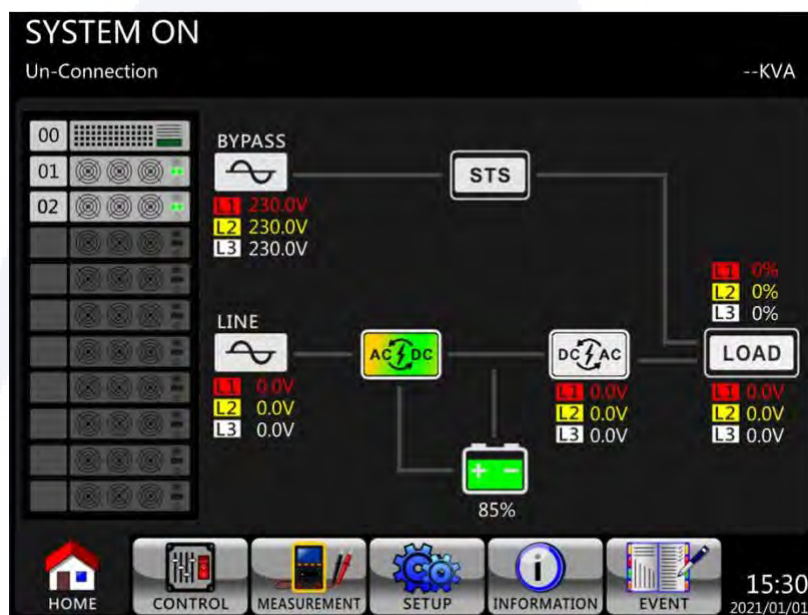

**Step 4:** Switch ON the input breaker (Q1). The UPS will enter into Standby Mode, if the setting of Bypass mode is disabled.

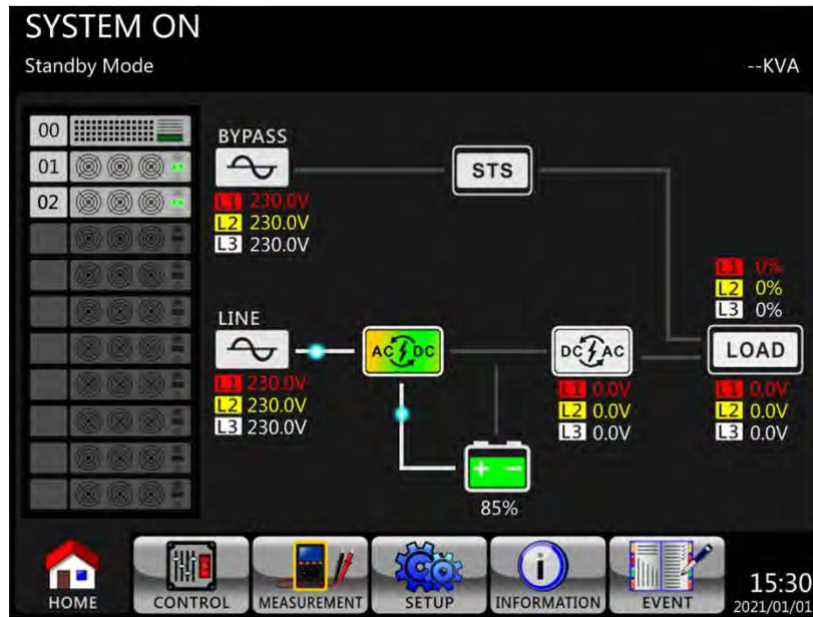

Or the UPS will enter into Bypass Mode, if the setting of Bypass mode is enabled.

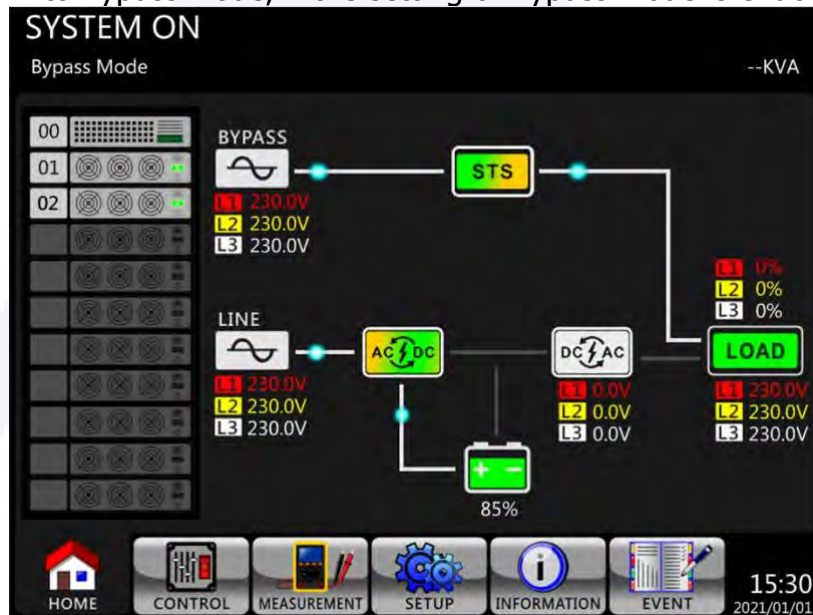

**Step 5:** Make sure that no warning or fault event occurs. If yes, please refer to Chapter 6 Troubleshooting to solve it.

**Step 6:** Press "Power" button for two seconds to enter into Line Mode as shown below.

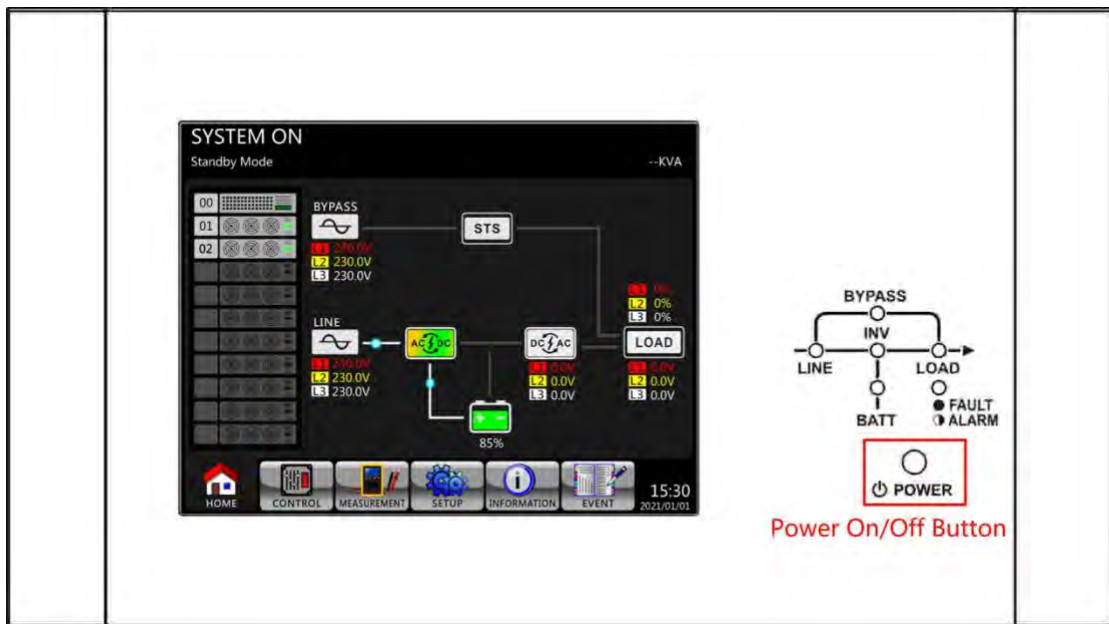

After turning on, UPS will do self-test and start up inverter. UPS will be transferred to Line mode when all power modules are ready.

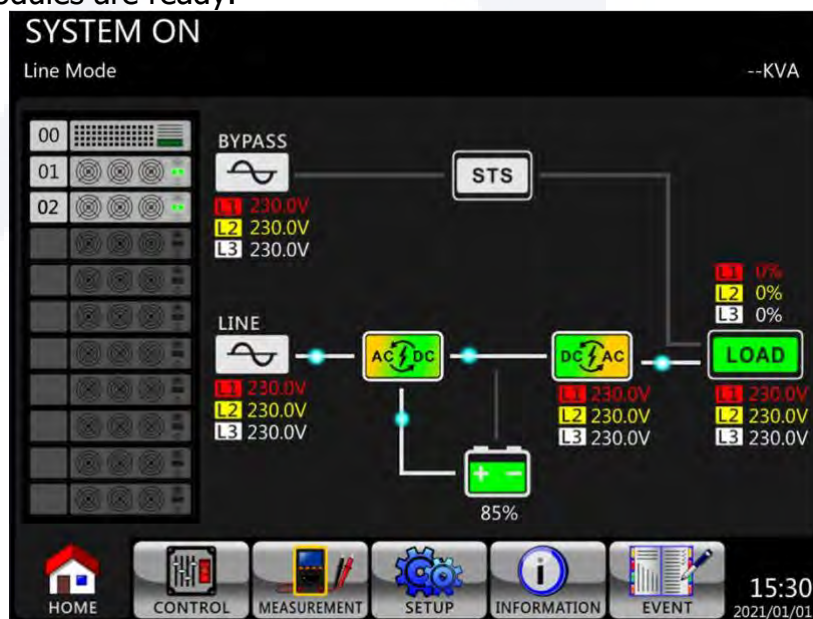

**Step 7:** Switch ON the output breaker (Q3). AC startup procedure is complete.

### 3.3.2 Cold Start Startup

**Step 1:** Switch ON the battery Breaker.

**Step 2:** Press the "Battery Start" button on any one of Power Modules to start up the control power of all Power modules and STS module as shown below.

Battery Start Button

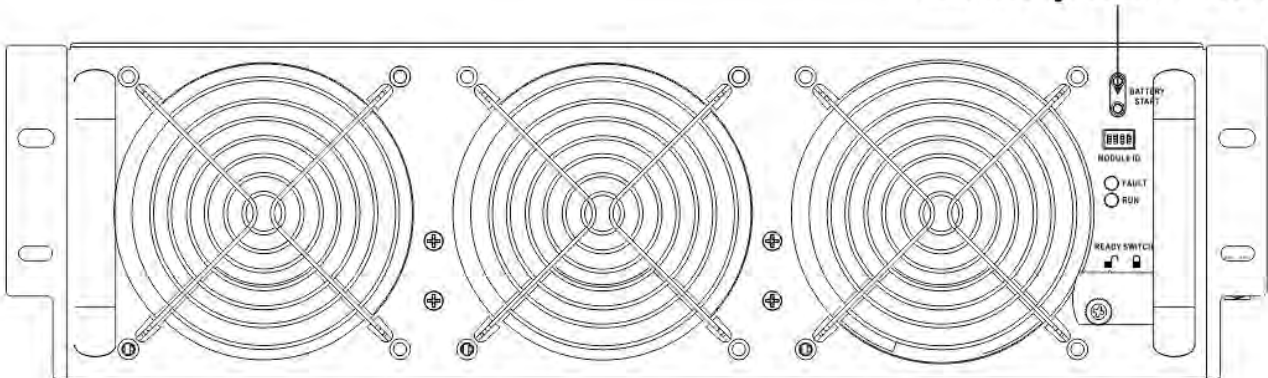

**Step 3:** After pressing the "Battery Start" button, UPS will enter into Standby mode. Refer to the diagram below for LCD display.

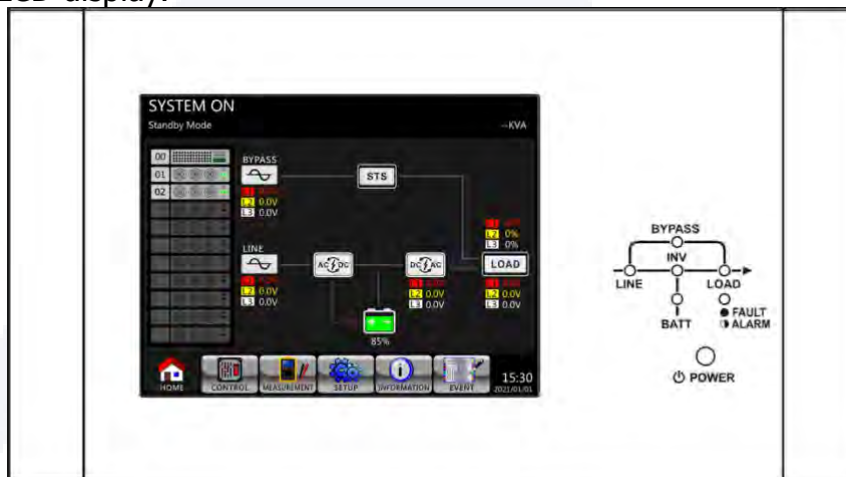

**Step 4:** Before UPS enters into shutdown mode, please press "POWER" button for 2 second immediately as shown in the diagram below.

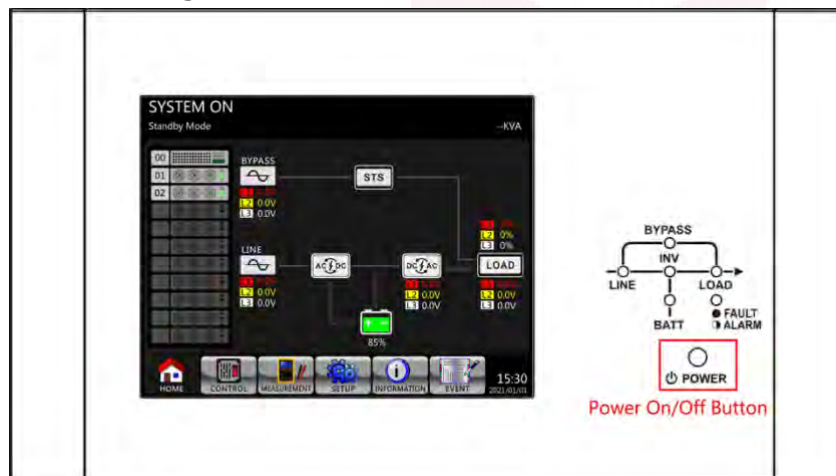

**Step 5:** Then, UPS will enter Battery Mode as shown in the diagram below.

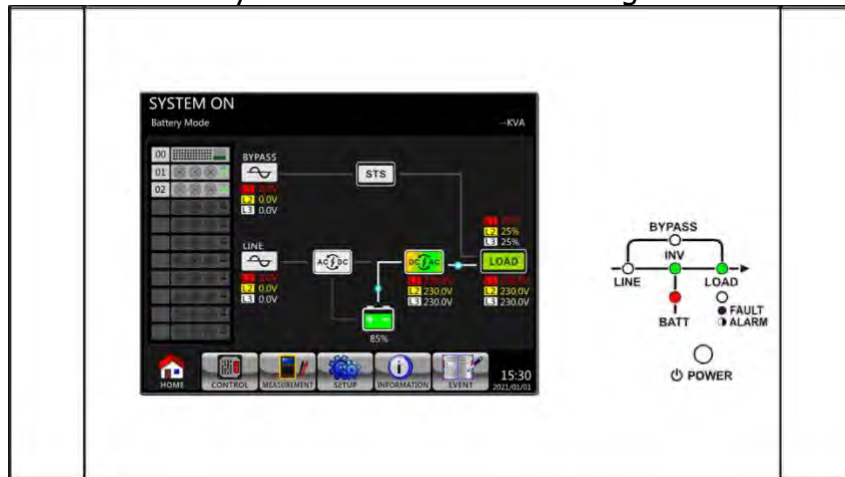

**Step 6:** Switch ON the output breaker (Q3). Cold start startup procedure is complete.

### 3.3.3 Maintenance Bypass Operation

Follow the instruction to transfer to Maintenance Bypass and UPS protection as below.

#### 3.3.3.1 Transfer to maintenance bypass

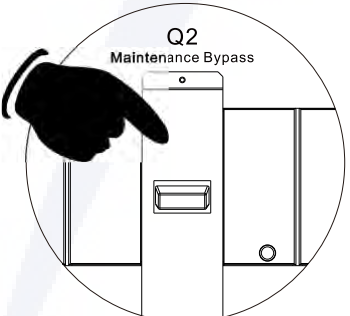
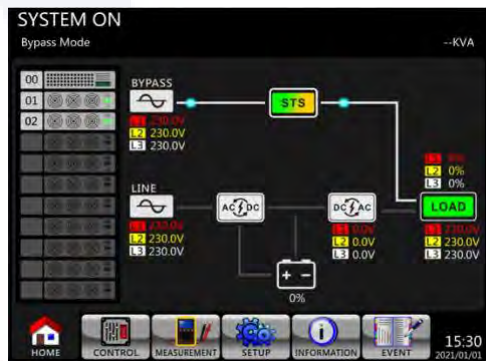
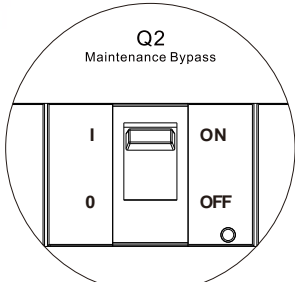
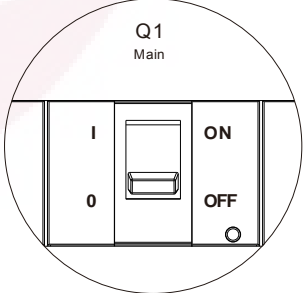
<p><b>Step 1:</b></p>	<p>Remove the mechanical lock plate of Maintenance Bypass Breaker.</p> 	<p><b>Step 2</b></p>	<p>Make sure the UPS operates in Bypass mode as shown below.</p> 
<p><b>Step 3</b></p>	<p>Switch ON the Maintenance Bypass Breaker as shown below.</p> 	<p><b>Step 4</b></p>	<p>Switch OFF the Main Breaker (Q1) as shown below.</p> 
<p><b>Step 5</b></p>	<p>It is possible to change the STS module, Power Module and Battery Module.</p>		

### 3.3.3.2 Transfer to UPS Protection

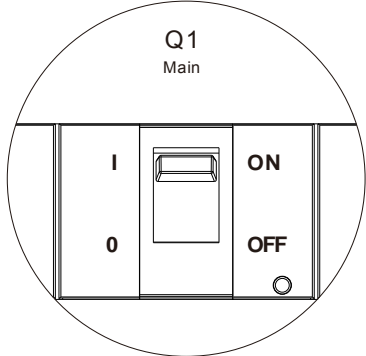
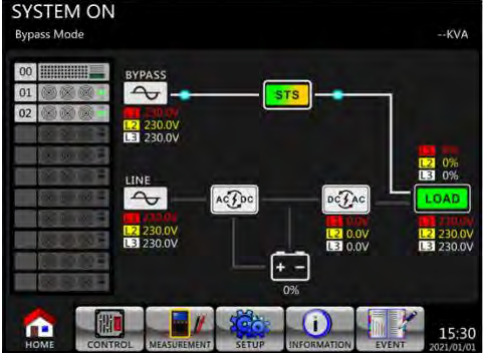
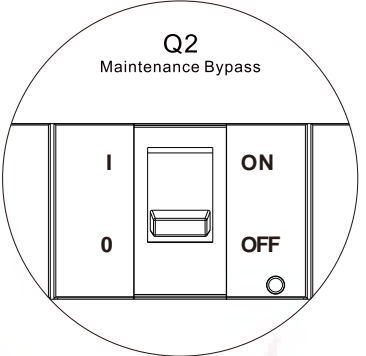
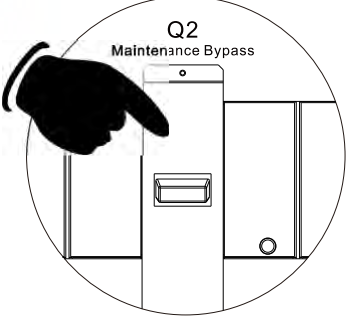
<p><b>Step 1</b></p>	<p>Make sure the maintenance is complete. The Power Modules and STS module have been installed well.</p>	<p><b>Step 2</b></p>	<p>Switch ON the Main Breaker (Q1) as shown below.</p>  <p>The diagram shows a circular view of a main breaker labeled 'Q1 Main'. The handle is in the 'ON' position, and the indicator 'ON' is lit. The 'OFF' position is also visible.</p>
<p><b>Step 3</b></p>	<p>Please enter LCD SETUP MENU and choose "SYSTEM" to ensure that the "Bypass mode" is enabled. If the "Bypass mode" is disabled, you have to set it as "enabled". Then, exit the SETUP menu and check if the UPS operates in bypass mode.</p>  <p>The screenshot shows the 'SYSTEM ON' LCD menu. The 'BYPASS Mode' is highlighted in green, indicating it is enabled. The menu also shows 'LINE' and 'LOAD' status. The bottom navigation bar includes 'HOME', 'CONTROL', 'MEASUREMENT', 'SETUP', 'INFORMATION', and 'EVENT'. The time is 15:30 and the date is 2021/01/01.</p>	<p><b>Step 4</b></p>	<p>Turn off Maintenance Bypass Breaker as shown below.</p>  <p>The diagram shows a circular view of a maintenance bypass breaker labeled 'Q2 Maintenance Bypass'. The handle is in the 'OFF' position, and the indicator 'OFF' is lit. The 'ON' position is also visible.</p>
<p><b>Step 5</b></p>	<p>Lock back the mechanical lock plate as shown below.</p>  <p>The diagram shows a circular view of the maintenance bypass breaker labeled 'Q2 Maintenance Bypass'. A hand is shown locking the mechanical lock plate on the handle.</p>		

### 3.3.4 Turn off Operation

#### 3.3.4.1 Turn off Operation in Bypass Mode/ Standby Mode

When the UPS neither is turned on nor turned off, the UPS operates in the Standby Mode or Bypass Mode. It depends on the "Bypass Mode" Setting.

The LCD diagrams are shown below.

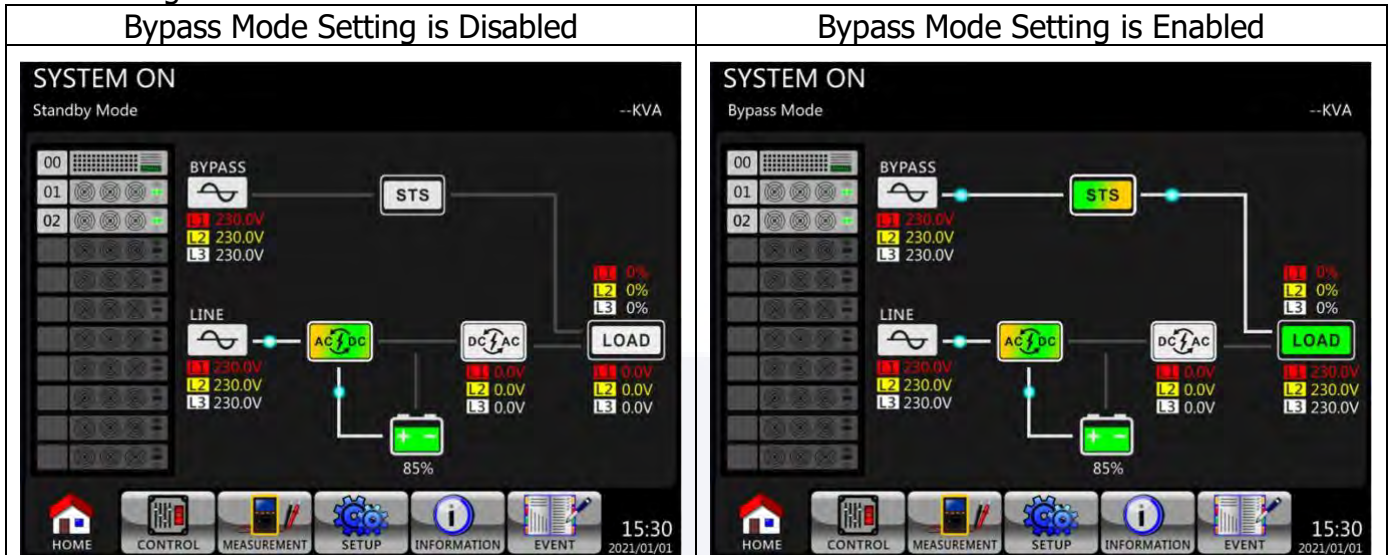

**Step 1:** Switch OFF the Main Breaker. The LCD diagrams are shown below.

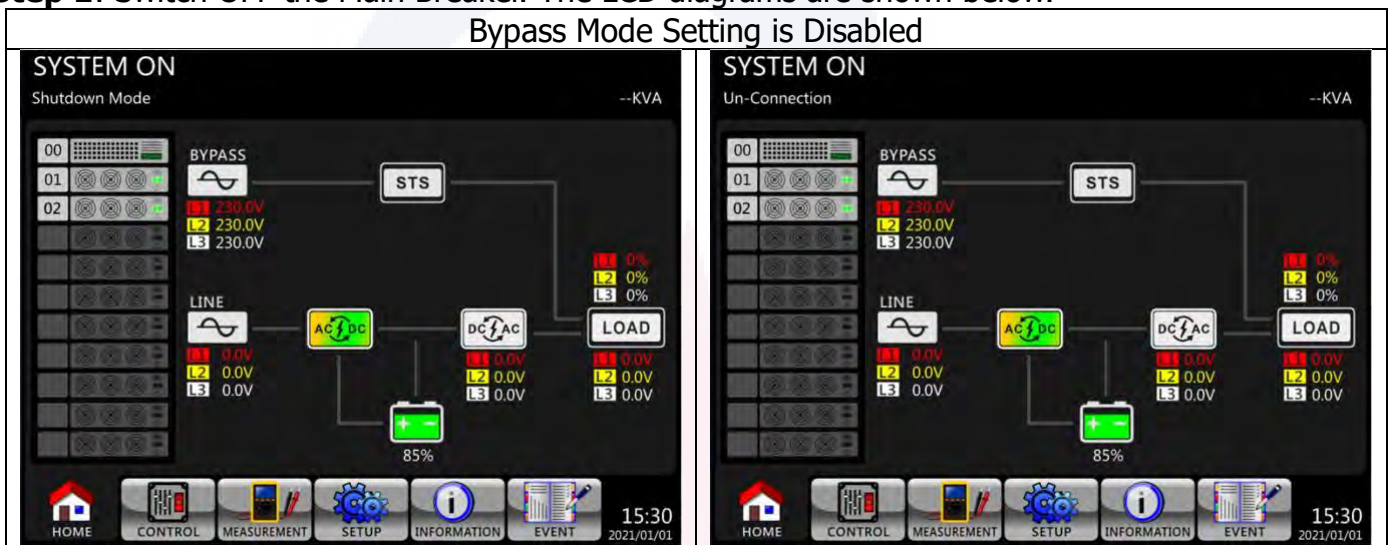

UPS enters Shutdown Mode.

It is normal the Un-Connection is shown when Power Modules have shut off their control power.



## Bypass Mode Setting is Enabled

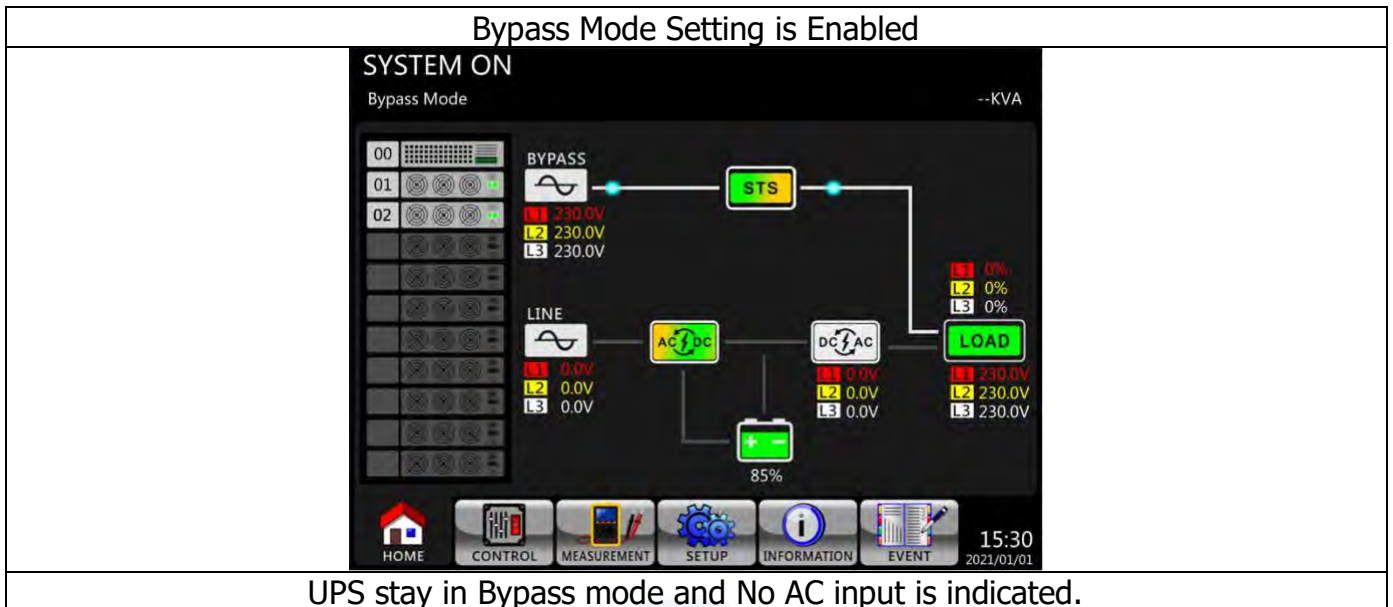

UPS stay in Bypass mode and No AC input is indicated.

**Step 2:** Switch OFF the external power switch to disconnect the AC power to the UPS. Wait until the LCD is OFF.

**Step 3:** Switch OFF the battery breaker if the UPS will disconnect from AC power for a long time.

### 3.3.4.2 Turn off Operation in Line Mode

The LCD diagrams are shown below when the UPS operates in the Line Mode.

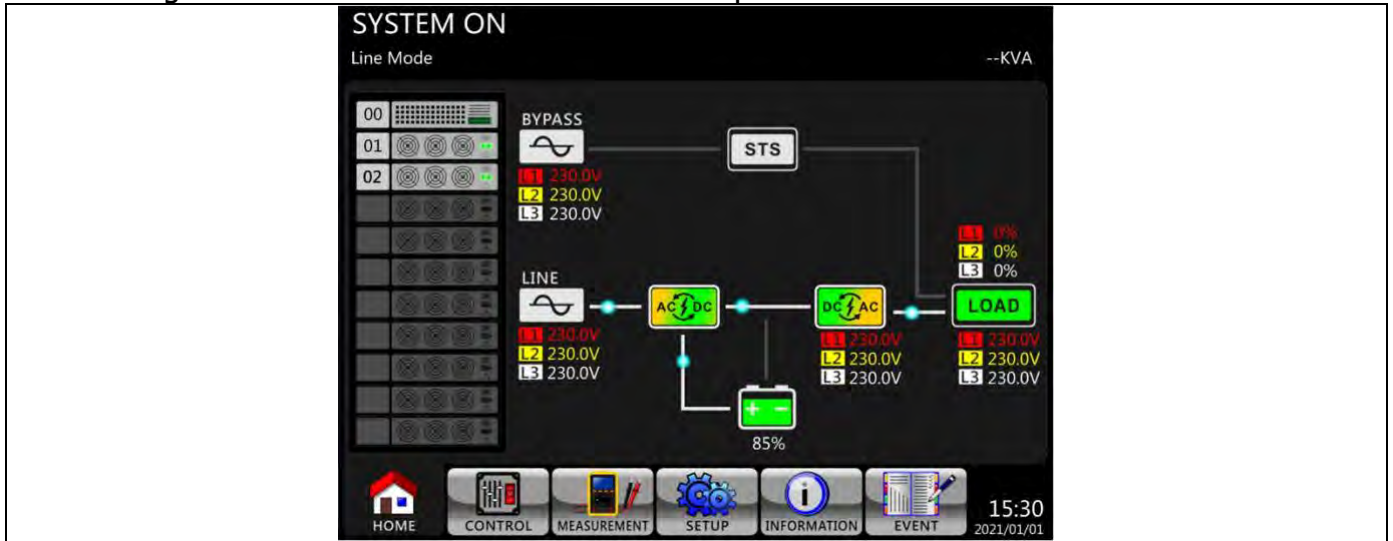

**Step 1:** Press "POWER" button for 2 second to turn off the UPS. Or use the LCD operation (Control → Turn Off) to turn off the UPS.

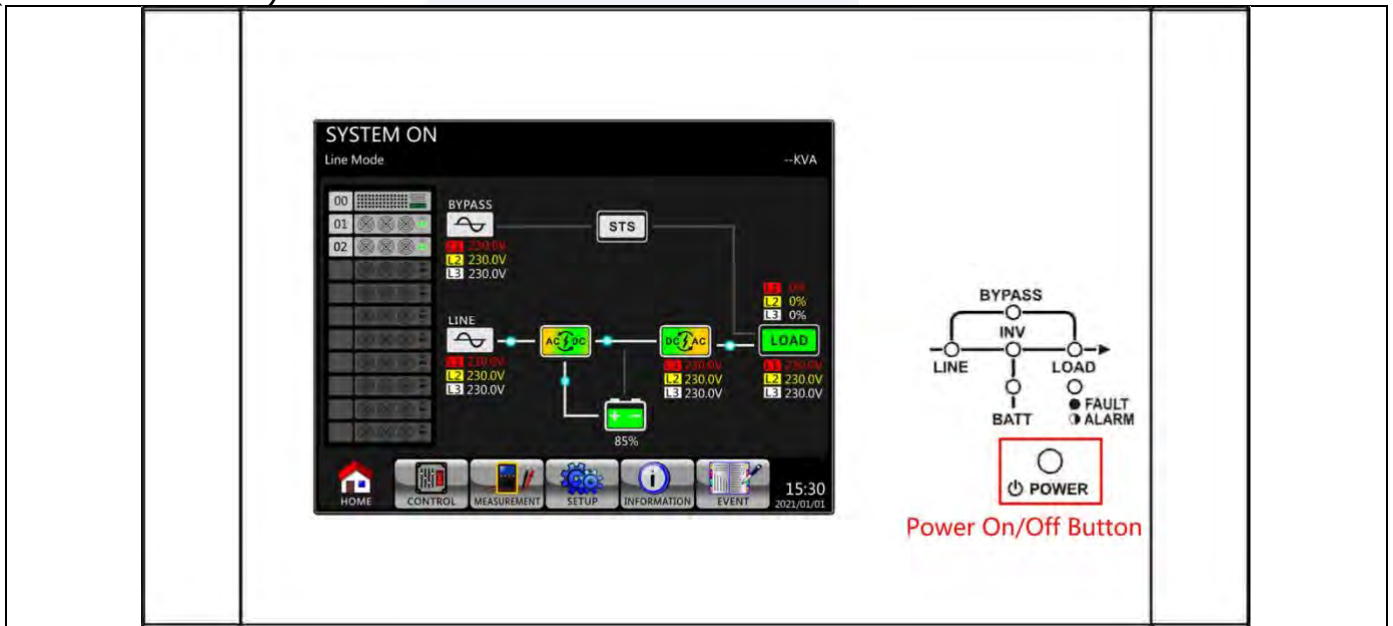

After turning off, the UPS will transfer to Standby Mode or Bypass Mode depending on the "Bypass Mode" Setting.

Next, follow the **Turn off Operation in Bypass Mode/ Standby Mode** procedure.

### 3.3.4.3 Turn off Operation in Battery Mode

The LCD screen is shown below when the UPS operates in the Battery Mode.

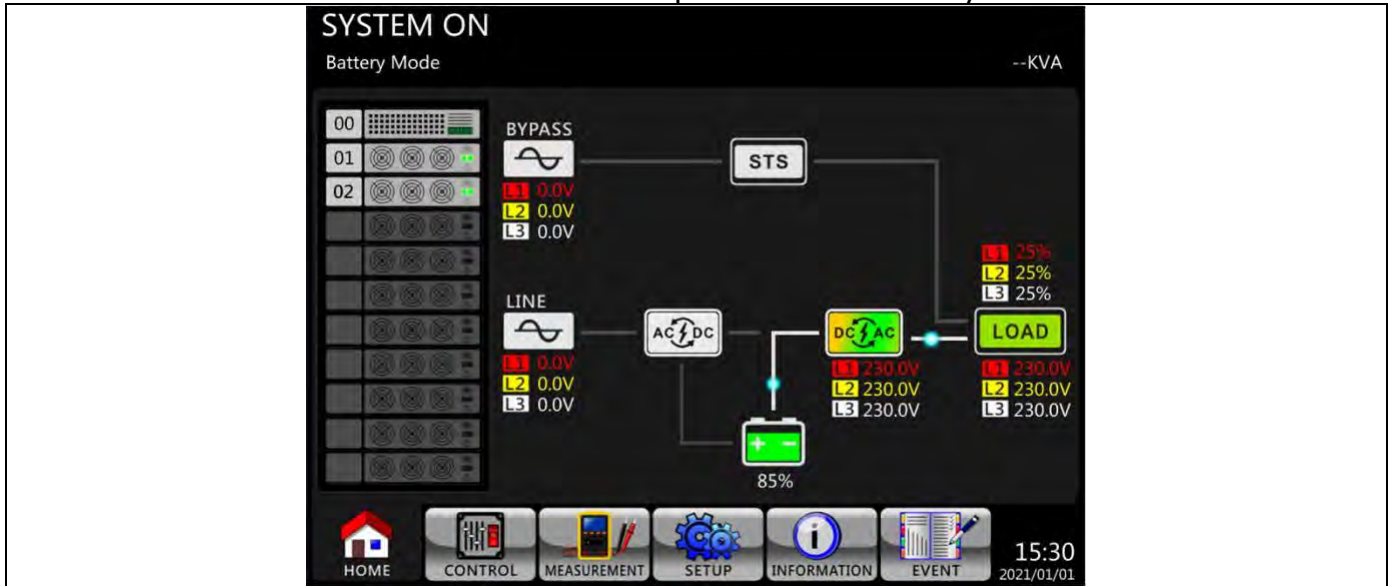

**Step 1:** Press "POWER" button for 2 seconds to turn off the UPS. Or use the LCD operation (Control → Turn Off) to turn off the UPS.

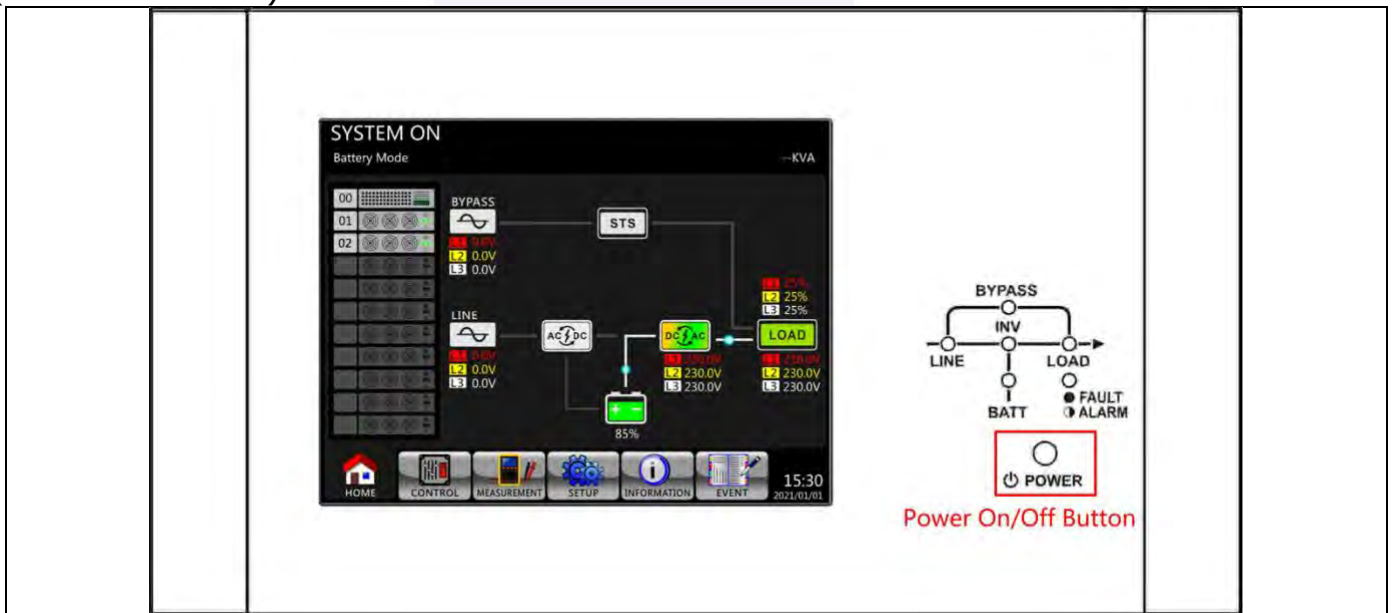

After turning off, the UPS will transfer to Standby Mode.

Next, follow the **Turn off Operation in Bypass Mode/ Standby Mode** procedure.

## 4. Control Panel and Display Description

### 4.1 Introduction

This control panel and display description are located on the front door of the UPS cabinet. It is the USER control, monitoring of all measured parameters, UPS and battery status and alarms. The control panel is divided into four functional areas: (1) LCD display, (2) LED indications, (3) Control keys, (4) Audio Alarm, as shown in Figure 4-1.

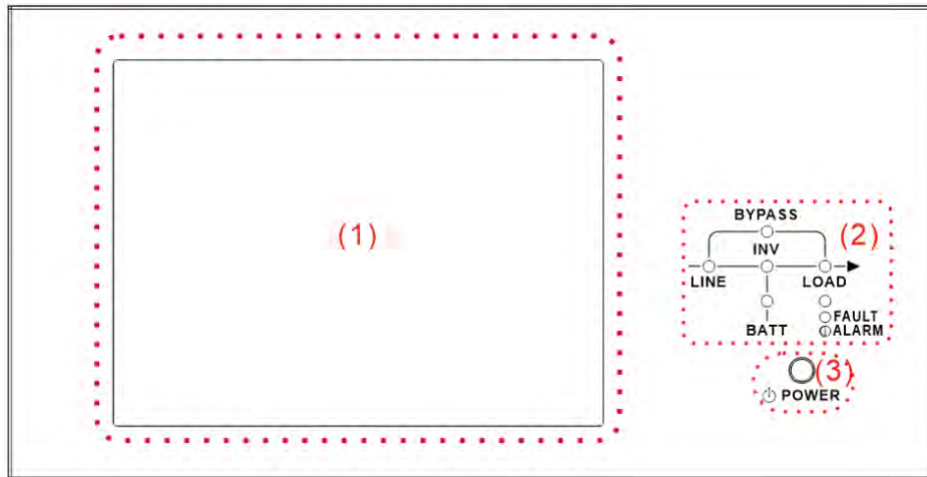

Figure 4-1 Control panel

- (1) LCD display: Graphic display for real-time UPS status and all measured parameters.
- (2) LED indications. Refer to **Table 4-1**.
- (3) Control key. Refer to **Table 4-2**.
- (4) Audible Alarm. Refer to **Table 4-3**.

**Table 4-1:** LED indications

LED	Color	Status	Definition
LINE	Green	On	Input source is normal.
		Flashing	Input source is abnormal.
		Off	No input source
BYPASS	Yellow	On	Load on Bypass.
		Flashing	Input source is abnormal.
		Off	Bypass circuit is not operating.
LOAD	Green	On	There is power output for the load.
		Off	There is no power output for the load.
INV	Green	On	Load on inverters.
		Off	Inverter circuit is not operating.
BATTERY	Red	On	Output power from Battery.
		Flashing	Low battery
		Off	Battery converter is normal and battery is charged.
FAULT/ ALARM	Red	On	UPS fault.
		Flashing	UPS alarm.
		Off	Normal.

**Table 4-2:** Control key table

Control Key	Description
POWER	Turn on UPS or Turn off UPS. (hold 2 seconds)

**Table 4-3:** Audible Alarm

Audio Type	Description
Power on/off	Buzzer sounds 2 seconds.
Battery mode	Buzzer sounds every 2 seconds.
Low battery	Buzzer sounds every half seconds.
UPS alarm	Buzzer sounds every 1 second.
UPS fault	Buzzer continuously sounds.

## 4.2 Screen Description

### 4.2.1 Start Screen

Upon starting, the UPS executes self-test. The initial screen displays and remains still in approximately 5 seconds as shown in Figure 4-2.



Figure 4-2 Initial screen

### 4.2.2 Main Screen

After initialization, the main screen will display as Figure 4-3. Main screen is divided into six parts.

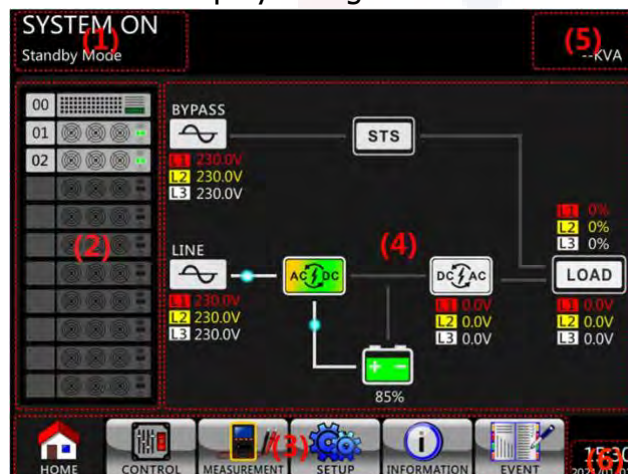







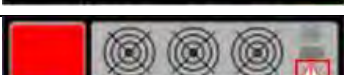



Figure 4-3 Main screen

(1) UPS Mode: Current operation mode.

(2) Module Status: It will show active module no. Touch each module icon to enter measurement screen. The meanings of each icon are listed as below.

Module icon	Explanation
	STS icon with ID no.
	Power module icon with ID no.
	No power module
	Power module output on
	Power module output off
	Power module charger on
	Power module charger off
	Power module fault
	Power module is operated normally.

(3) Main Menu: Touch icon to enter sub screen.

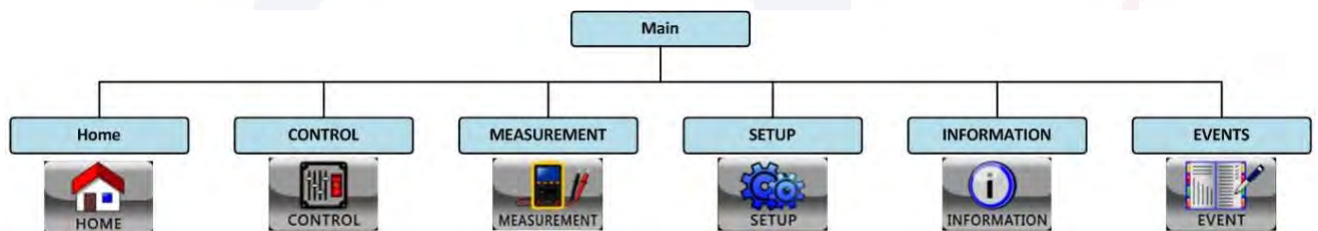



Figure 4-4 Menu tree

(4) UPS Flow Chart: Current flow chart and measurement data.

(5) UPS power rating.

(6) Date and Time.

### 4.2.3 Control Screen

Touch  icon to enter into the sub-menu as shown in Figure 4-5 and 4-6.

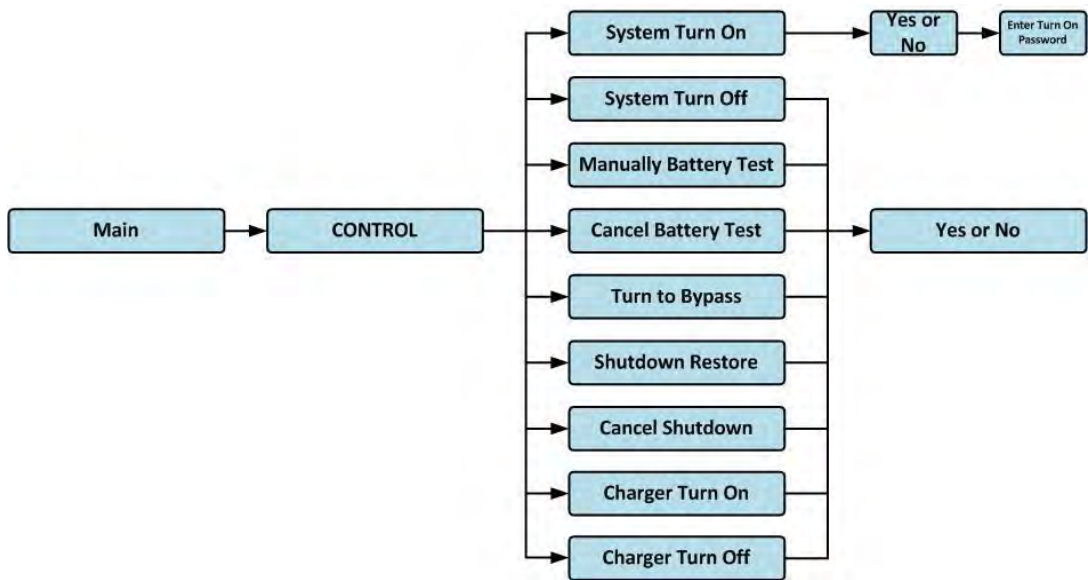

Figure 4-5 Control menu tree



Figure 4-6 Control screen page

Touch any control option directly. Then, confirmation screen will pop up. Touch **Yes** icon to confirm command or touch **No** icon to cancel command as shown in Figure 4-7.



Figure 4-7 Confirmation screen

#### 4.2.5 Measurement Screen

Touch **MEASUREMENT** icon to enter into the sub-menu. There are two sub-menus, system measurement and module measurement. Touch **SYSTEM** icon to monitor system measurement value or **MODULE** icon to monitor module measurement value. You may choose Input, Output, Bypass, Load or Battery to monitor detailed status under "System" or "Module" directory. Please refer all screens in Figure 4-8 and 4-9. All detailed measurement items are listed in Table 4-4.

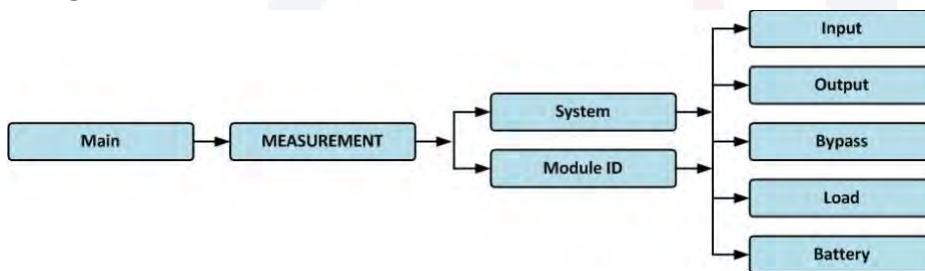

Figure 4-8 Measurement menu







Figure 4-9 System Measurement Screens

Touch **MODULE** icon to monitor module measurement value.



Figure 4-10 Module Measurement Screens

The measurement can be read listed in **Table 4-4**.

**Table 4-4:** Measurement data

Menu	Item	Explanation
Input	L-L Voltage (V)	Input voltage (L1L2, L2L3, L3L1). Units 0.1V.
	Frequency (Hz)	Input Frequency (L1, L2, L3). Units 0.1Hz.
Output	L-L Voltage (V)	Output voltage (L1L2, L2L3, L3L1). Units 0.1V.
	L-N Current (A)	Output phase current (L1, L2, L3). Units 0.1A.
	Frequency (Hz)	Output Frequency (L1, L2, L3). Units 0.1Hz.
	Power Factor	Output Power Factor (L1, L2, L3).
Bypass	L-L Voltage (V)	Bypass voltage (L1L2, L2L3, L3L1). Units 0.1V.
	Frequency (Hz)	Bypass Frequency (L1, L2, L3). Units 0.1Hz.
	Power Factor	Bypass Power Factor (L1, L2, L3).
Load	Sout (KVA)	Apparent power. Units 0.1KVA.
	Pout (KW)	Active power. Units 0.1KW.
	Load Level (%)	The percentage of the UPS rating load. Units 1%.
Battery	Positive Voltage (V)	Battery Positive Voltage. Units 0.1V.
	Negative Voltage (V)	Battery Negative Voltage. Units 0.1V.
	Positive Current (A)	Battery Positive Current. Units 0.1A.
	Negative Current (A)	Battery Negative Current. Units 0.1A.
	Remain Time (Sec)	Battery run time remaining. Units 1sec.
	Capacity (%)	The percentage of the capacity of the battery. Units 1%.
	Test Result	Battery test result
	Charging Status	Battery charging status
	Temperature1(°C)	Battery cabinet temperature of STS module. Units 0.1°C.

#### 4.2.6 Setup Screen

Touch the  icon to enter into the sub-menu. It's required to enter password to access General, SYSTEM, BATTERY and PRE-ALARM sub-menus as shown in Figure 4-11 and 4-12.

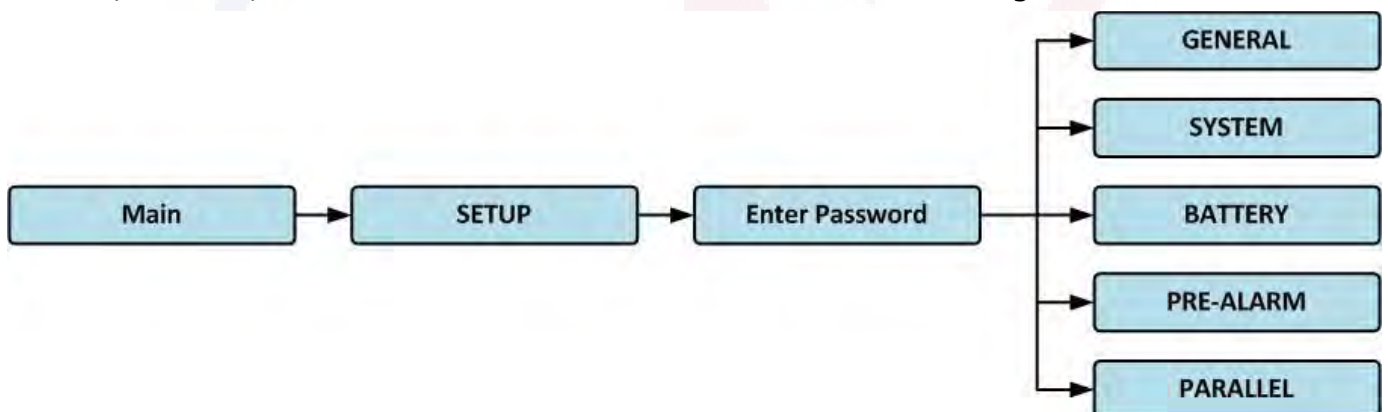

Figure 4-11 Setup menu

Touch the grey column and it will pop up number keyboard. Please enter 4-digit password and select  icon to enter SETUP sub-menu. If incorrect password is entered, the LCD screen will ask for retry.



Figure 4-12 Enter password screen

There are two levels of password protection, user password and maintainer password.

The default password for user is "0000". It could be change by user.

The maintainer password is owned by service personnel.

Entering different level of password can access to different settings. The setting can be changed in different operation mode. The **Table 4-5** lists the relevant information.

**Table 4-5:** All setting items in Setup Menu

Setting item	UPS operation Mode	Standby Mode	Bypass Mode	Line Mode	Battery Mode	Battery Test Mode	Fault Mode	Converter Mode	ECO Mode	Authorization	
										User	Maintainer
General	Model Name	Y	Y	Y	Y	Y	Y	Y	Y		Y
	Language	Y	Y	Y	Y	Y	Y	Y	Y	Y	Y
	TIME	Y	Y	Y	Y	Y	Y	Y	Y		Y
	Change Password	Y	Y	Y	Y	Y	Y	Y	Y	Y	Y
	Baud Rate	Y	Y	Y	Y	Y	Y	Y	Y	Y	Y
	Audible Alarm	Y	Y	Y	Y	Y	Y	Y	Y	Y	Y
	Factory Reset	Y									Y
	EEPROM Reset	Y									Y
	Save Setting	Y	Y							Y	Y
	Startup Screen	Y	Y	Y	Y	Y	Y	Y	Y		Y
System	Output Voltage	Y	Y								Y
	Bypass Voltage Range	Y	Y	Y	Y	Y	Y	Y	Y		Y
	Bypass Frequency Range	Y	Y								Y
	Converter Mode	Y									Y
	ECO Mode	Y	Y								Y
	Bypass Mode	Y	Y								Y
	Auto-Restart	Y	Y	Y	Y	Y	Y	Y	Y		Y
	Power Walk in	Y	Y	Y	Y	Y	Y	Y	Y		Y
	Battery Mode Delay Time	Y	Y	Y			Y	Y	Y		Y
	System Shutdown Time	Y	Y	Y	Y	Y	Y	Y	Y		Y
	System Restore Time	Y	Y	Y	Y	Y	Y	Y	Y		Y
	Redundancy	Y	Y	Y	Y	Y	Y	Y	Y		Y
Power Rating Setting	Y	Y	Y	Y	Y	Y	Y	Y		Y	

Battery	Nominal Battery Voltage	Y	Y								Y
	Battery Capacity in Ah	Y	Y	Y			Y	Y	Y		Y
	Maximum Charging Current	Y	Y								Y
	Battery Low/Shutdown Setting	Y	Y	Y			Y	Y	Y		Y
	Periodic Battery Test	Y	Y	Y	Y	Y	Y	Y	Y		Y
	Battery Test Interval	Y	Y	Y	Y	Y	Y	Y	Y		Y
	Stop by Time	Y	Y	Y	Y		Y	Y	Y		Y
	Stop by Battery Voltage	Y	Y	Y	Y		Y	Y	Y		Y
	Stop by Battery Capacity	Y	Y	Y	Y		Y	Y	Y		Y
	Battery Age Alert	Y	Y	Y	Y	Y	Y	Y	Y		Y
	Temperature Compensation	Y	Y	Y	Y	Y	Y	Y	Y		Y
Charging Voltage	Y	Y								Y	
Pre-Alarm	Line Voltage Range	Y	Y	Y	Y	Y	Y	Y	Y		Y
	Line Frequency Range	Y	Y	Y	Y	Y	Y	Y	Y		Y
	Overload	Y	Y	Y	Y	Y	Y	Y	Y		Y
	Load Unbalance	Y	Y	Y	Y	Y	Y	Y	Y		Y

“Y” means that this setting item can be set in this operation mode.

### Setting Procedure

Step 1: Choose the setting item from GENERAL, SYSTEM, BATTERY and PRE-ALARM.

Step 2: Select modified item and it will show current value and setting in the screen. Simply choose current setting and it will list all alternatives. Please choose the modified setting.



Step 3: Choose  icon to confirm the setting change or choose  icon to cancel the setting.



Figure 4-13 Setting procedure

#### 4.2.6.1 Setup-General Screen

The Setup-General screen and setting list are shown in Figure 4-14 and **Table 4-6**. General setting can be set in any operating mode.



Figure 4-14 Setup-General screen

**Table 4-6:** Setup-General setting list

Setting Item	Sub Item	Explanation
Model Name		Set UPS Name (xxxxxxxxxx). The max. length is 10 characters.
Language	--	Provides 3 optional LCD languages: <ul style="list-style-type: none"> <li>● English (Default)</li> <li>● Traditional Chinese</li> <li>● Simplified Chinese</li> </ul>
TIME	Adjust Time	Set current date and time. (yyyy / mm / dd hour : min : sec) <b>MUST be set after UPS installation</b>
	System Installed Date	Set system installed date (yyyy / mm / dd) 2015/1/1 (Default)

		<b>MUST be set after UPS installation</b>
	System Last Maintain Date	Set system latest maintenance date (yyyy / mm / dd) <b>MUST be set after UPS installation</b>
	Battery Installed Date	Set battery installed date (yyyy / mm / dd) <b>MUST be set after UPS installation</b>
	Battery Last Maintain Date	Set battery latest maintenance date (yyyy / mm / dd) <b>MUST be set after UPS installation</b>
Baud Rate	--	Set COM Port0 Baud Rate <ul style="list-style-type: none"> <li>● 2400 (Default)</li> <li>● 4800</li> <li>● 9600</li> </ul> Set COM Port1 Baud Rate <ul style="list-style-type: none"> <li>● 2400 (Default)</li> <li>● 4800</li> <li>● 9600</li> </ul>
Audible Alarm	--	Set Audible Alarm <ul style="list-style-type: none"> <li>● Disable</li> <li>● Enable (Default)</li> </ul>
Factory Reset	--	Restore to factory default setting Refer to <b>Table 4-7</b>
EEPROM Reset	--	Set EEPROM default Refer to <b>Table 4-7</b>
Password	--	Set New Password. 0000 (Default)
Save Setting	--	Save EEPROM <b>Use this feature to save the setting(s) you have done.</b>

**Table 4-7:** EEPROM Reset Category list

	Setting Item	Factory Reset	EEPROM Reset
General	Model Name		
	Language	Y	Y
	Adjust Time		
	System Installed Date		Y
	System Last Maintain Date		Y
	Battery Installed Date		Y
	Battery Last Maintain Date		Y
	Change Password		Y
	Baud Rate		Y
	Audible Alarm	Y	Y
	Factory Reset	--	--
	EEPROM Reset	--	--
	EPO Function		Y
	Save Setting	--	--
System	Output Voltage		Y
	Bypass Voltage Range	Y	Y
	Bypass Frequency Range	Y	Y

	Converter Mode	Y	Y
	ECO Mode	Y	Y
	Bypass Mode	Y	Y
	Auto-Restart	Y	Y
	Power Walk In		Y
	Battery Mode Delay Time		Y
	Shutdown / Restore	Y	Y
	Power Rating Setting		Y
	Redundancy		Y
	CT Ratio Setting	Y	Y
	Battery	Nominal Battery Voltage	
Battery Capacity in Ah			Y
Maximum Charging Current			Y
Battery Low/Shutdown Setting		Y	Y
Battery Age Alert		Y	Y
Temperature Compensation		Y	Y
Auto-Restart Battery Voltage		Y	Y
Charging Voltage		Y	Y
Periodic Battery Test		Y	Y
Battery Test Interval		Y	Y
Stop by Time		Y	Y
Stop by Battery Voltage		Y	Y
Stop by Battery Capacity		Y	Y
Pre-Alarm		Y	

#### 4.2.6.2 Setup-System Screen

The Setup-System screen and setting list as shown in Figure 4-15 and table 4-8. System setting can be set only when UPS is operated in certain mode. Please check setting item availability table 4-5 for the details. If it's not set up under specific mode, the warning screen will appear. Refer to figure 4-16.



Figure 4-15 Setup-System screen

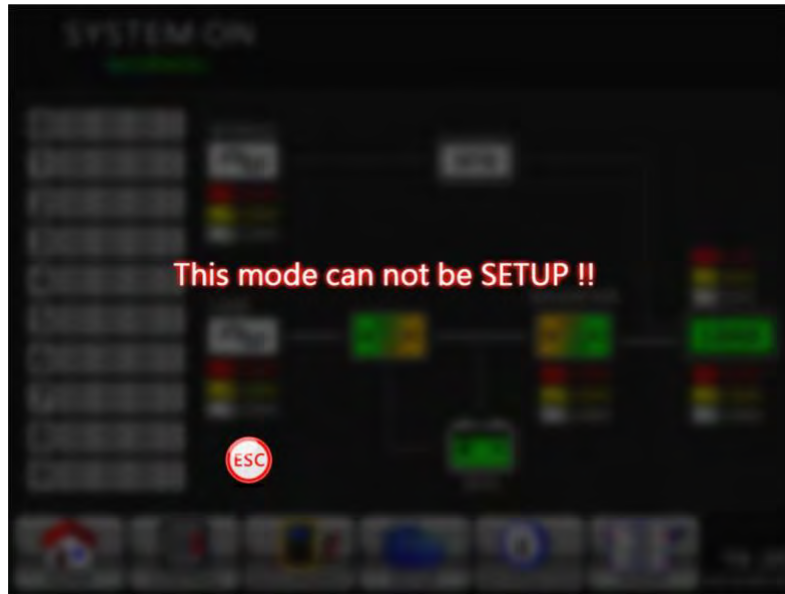

Figure 4-16 Warning screen

Setup-System setting list is shown in **Table 4-8**.

**Table 4-8:** Setup-System setting list

Setting Item	Sub Item	Explanation
Output Voltage	--	Set output voltage <ul style="list-style-type: none"> <li>● 480Vac (Default)</li> </ul> <b>MUST be reviewed after UPS installation</b>
BYPASS SETTING	Bypass Voltage Range	Set bypass voltage range: Upper limit <ul style="list-style-type: none"> <li>● +15% (Default)</li> </ul> Lower limit <ul style="list-style-type: none"> <li>● -10%</li> <li>● -20% (Default)</li> <li>● -30%</li> </ul>
	Bypass Frequency Range	Set bypass Frequency range: Upper/ Lower limit <ul style="list-style-type: none"> <li>● +/- 1Hz</li> <li>● +/- 2Hz</li> <li>● +/- 4Hz (Default)</li> </ul>
Converter Mode	--	Set converter mode <ul style="list-style-type: none"> <li>● Disable (Default)</li> <li>● Enable</li> <li>● 50Hz</li> <li>● 60Hz</li> <li>● AUTO</li> </ul>
ECO Mode	--	Set ECO mode <ul style="list-style-type: none"> <li>● Disable (Default)</li> <li>● Enable</li> </ul>
Bypass Mode	--	Set bypass mode <ul style="list-style-type: none"> <li>● Disable</li> <li>● Enable (Default)</li> </ul> <b>MUST be reviewed after UPS installation.</b> If you need the Bypass power when UPS is OFF, please



		enable it.
Auto-Restart	--	Set auto-restart <ul style="list-style-type: none"> <li>● Disable</li> <li>● Enable (Default)</li> </ul> After "Enable" is set, once UPS shutdown occurs due to low battery and then utility restores, the UPS will return to line mode.
Power Walk in		Set power walk in upper/lower limits <ul style="list-style-type: none"> <li>● +/- 1s time step (setting range: 1s ~ 10s)</li> </ul>
Battery Mode Delay Time	--	Set system shutdown delay time in battery mode (0~990min). <ul style="list-style-type: none"> <li>● 0: Disable (Default)</li> <li>● Not 0: Enable</li> </ul> When this feature is enabled, UPS will shut off output after UPS operates in Battery mode for certain minute.
Shutdown/ Restore	System Shutdown Time	Set system shutdown time (0.2~99min) <ul style="list-style-type: none"> <li>● 0.2 min (Default)</li> </ul> This delay time will start counting when the CONTROL-Shutdown Restore command is executed.
	System Restore Time	Set system restore time (0~9999min) <ul style="list-style-type: none"> <li>● 1 min (Default)</li> </ul> This delay time will start counting after shutdown time is elapsed when the CONTROL-Shutdown Restore command is executed.
Power rating setting	--	Set power rating value per module <ul style="list-style-type: none"> <li>● 70KVA</li> </ul>
Redundancy	--	Set total power and redundancy Redundancy: the QTY of redundant power module <b>MUST be set after UPS installation or the QTY of Power Module is changed</b>
CT Ratio Setting	--	Enable(Default) Change current transformer Ratio Setting

#### 4.2.6.3 Setup-Battery Screen

The Setup-Battery screen and setting list as shown in Figure 4-17 and table 4-9. Battery setting can be set only when UPS is operated in standby mode. If it's not in standby mode, the warning screen will appear as shown in Figure 4-16.



Figure 4-17 Setup-Battery Screen

Battery setting can be set only when UPS is operating in standby mode. If it's not in standby mode, the warning screen will appear as shown in Figure 4-23. See Setup-Battery setting list in **Table**

**Table 4-9:** Setup-Battery setting list

Setting Item	Sub Item	Explanation
Nominal Battery Voltage	--	Set battery nominal voltage <ul style="list-style-type: none"> <li>● 16x12V (Default)</li> <li>● 18x12V</li> <li>● 20x12V</li> </ul> <b>MUST be set after UPS installation</b>
Battery Capacity in Ah	--	Set battery capacity. (0~999) <ul style="list-style-type: none"> <li>● 9Ah (Default)</li> </ul> <b>MUST be set after UPS installation or Battery capacity is changed.</b>
Maximum Charging Current	--	Set battery maximum charging current (1~128A) 1A (Default) <b>MUST be set after UPS installation or Battery capacity is changed.</b>
Battery Low/Shutdown Setting	Low Voltage	Set battery low voltage (10.5~11.5V)x(battery Number) <ul style="list-style-type: none"> <li>● 11.4V x Battery Number (Default)</li> </ul>
	Low Capacity	Set battery low capacity (20~50%) <ul style="list-style-type: none"> <li>● 20% (Default)</li> </ul>
	Shutdown Voltage	Set battery voltage point for system shutdown in battery mode (10.0~11V) x (battery Number) <ul style="list-style-type: none"> <li>● 10.7V x Battery Number (Default)</li> </ul>
Battery Test	Periodic Battery Test	Set periodic battery test disable or enable <ul style="list-style-type: none"> <li>● Disable (Default)</li> <li>● Enable</li> </ul>
	Battery Test Interval	Set battery test interval (7~99 Days) <ul style="list-style-type: none"> <li>● 30 Days (Default)</li> </ul>
	Stop by Time	Set testing time for battery test (10~1000sec) <ul style="list-style-type: none"> <li>● 10 sec (Default)</li> </ul>
	Stop by Battery	Set stop battery voltage in battery test (11~12V) x

	Voltage	(battery Number) ● 11V x Battery Number (Default)
	Stop by Battery Capacity	Set battery capacity to stop battery-testing. (20~50%) ● 20% (Default)
Battery Age Alert	Battery Age Alert (Months)	Set battery age for replacement. (Disable,12~60Months) ● Disable (Default) If this feature is enabled and the battery has been installed over this period, there is a warning "Battery Age Alert" to indicate it.
Temperature Compensation	--	Set battery temperature compensation. (0~-5 (mV/C/cl)) ● 0(mV/C/cl) (Default)
Auto Restart BATT Volt	--	Set battery auto restart voltage ● 0V (Default)
Charging Voltage	--	Set battery charging voltage. (14.1~14.4V) ● 14.1V(Default) Set battery float voltage. (13.5~14.0V) ● 13.7V(Default)

#### 4.2.6.4 Pre-Alarm Screen

The Setup-Pre-Alarm screen and setting list as shown in Figure 4-18 and table 4-9. Pre-Alarm setting can be set in any operation mode.



Figure 4-18 Setup-Pre-Alarm screen

Pre-Alarm setting can be set in any operation mode. See Setup-Pre-Alarm setting list in **Table 4-10**.

**Table 4-10:** Setup-Pre-Alarm setting list

Setting Item	Sub Item	Explanation
Line Voltage Range	--	Set line voltage range: Upper limit

		<ul style="list-style-type: none"> <li>● 20% (Default)</li> </ul> Lower limit <ul style="list-style-type: none"> <li>● -5%</li> <li>● -10%</li> <li>● -15%</li> <li>● -20% (Default)</li> </ul>
Line Frequency Range	--	Set line frequency range: Upper / Lower limit <ul style="list-style-type: none"> <li>● +/- 1Hz</li> <li>● +/- 2Hz</li> <li>● +/- 3Hz</li> <li>● +/- 4Hz (Default)</li> </ul>
Load	--	Set UPS Overload percentage (40~100%) <ul style="list-style-type: none"> <li>● 100% (Default)</li> </ul> Set UPS load unbalance percentage (20~100%) <ul style="list-style-type: none"> <li>● 100% (Default)</li> </ul>

### 4.2.6.5 Setup-OTHERS Screen

Use UP and DOWN icons to switch different sub-menus. Press ENTER icon to go into the **OTHERS** setting screen, as shown in Figure 4-19.



Figure 4-19 Setup-OTHERS screen

### 4.2.7 Information Screen

Touch  icon to enter into the sub-menu. In this Information screen, you can check the UPS configuration of the unit. There are three sub-menus, Identification, System and Battery.

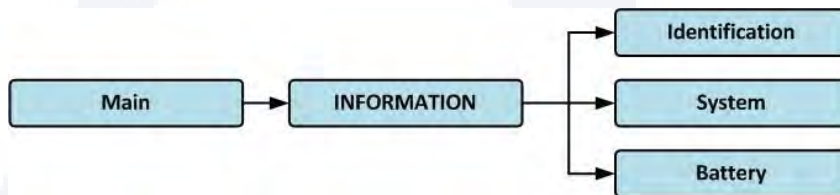

Figure 4-20 Information menu

#### 4.2.7.1 INFORMATION - Identification Screen

When Identification submenu is clicked, the Model Name, Serial No. and Firmware Version will be displayed, as shown in Figure 4-21.



Figure 4-21 Identification screen page

#### 4.2.7.2 INFORMATION - System Screen

When System submenu tab is touched, the system power, nominal voltage, nominal frequency ... etc. information will be displayed, as shown in Figure 4-22 and 4-23. Touch UP and DOWN arrows to switch different pages.

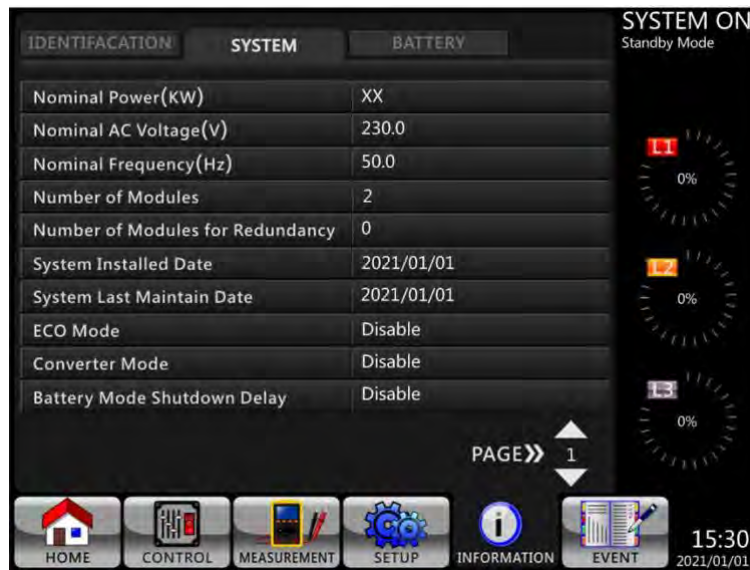

Figure 4-22 INFORMATION System screen page 1



Figure 4-23 INFORMATION System screen page 2

### 4.2.7.2 INFORMATION - Battery Screen

When Battery submenu tab is touched, the Battery nominal voltage, capacity, charging current ... etc. information will be displayed, as shown in Figure 4-24.



Figure 4-24 INFORMATION Battery screen page

### 4.2.8 Events Screen

When event occurs, you will see flashing  icon in the Main Screen as shown in Figure 4-25.

You also can touch  icon to check the latest event lists, history events and reset all events as shown in Figure 4-26.

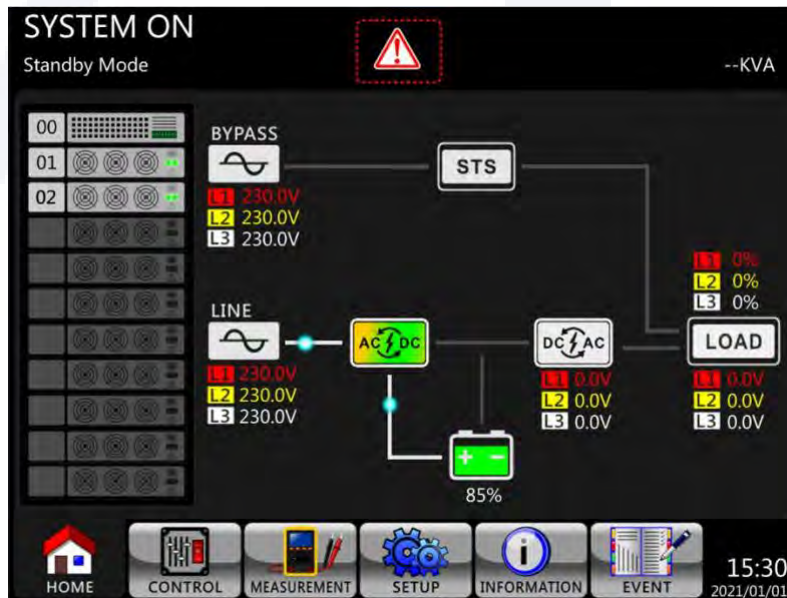

Figure 4-25 Alarm warning screen



Figure 4-26 Events menu

### 4.2.8.1 Current Events

When event occurs, it will display Module ID and alarm code in Current Events screen. It can save up to 50 events in current list. Only 10 events can be listed in one page. Therefore, if it exceeds more than 10, you have to press  icon to read other event as shown in Figure 4-27.



Figure 4-27 Current Events screen

### 4.2.8.2 History Events

The detailed event information is saved in history events. It can save up to 500 events in history events. When warning occurs, it will display alarm code, alarm time and Module ID. When fault event occurs, it will display alarm details, alarm time and Module ID. (Refer to **Table 4-12** Alarm List) In order to record more historical information about the UPS system, the important setting changed (refer to **Table 4-13** Important setting changed), UPS operation mode changes (refer to **Table 4-14** UPS mode change) and control action executes (refer to **Table 4-15** Control execution) will be saved in History Events. Refer to Figure 4-28 for display screen.



Figure 4-28 History Events screen



### 4.2.8.3 Reset All Events

The Maintainer password is required to enter Reset All Events screen as shown in Figure 4-29. After entering correct password, it will pop up reconfirmed screen. Then, touch **Yes** icon to reset all events or touch **No** icon to cancel this action as shown in Figure 4-30.



Figure 4-29 Reset All Events screen

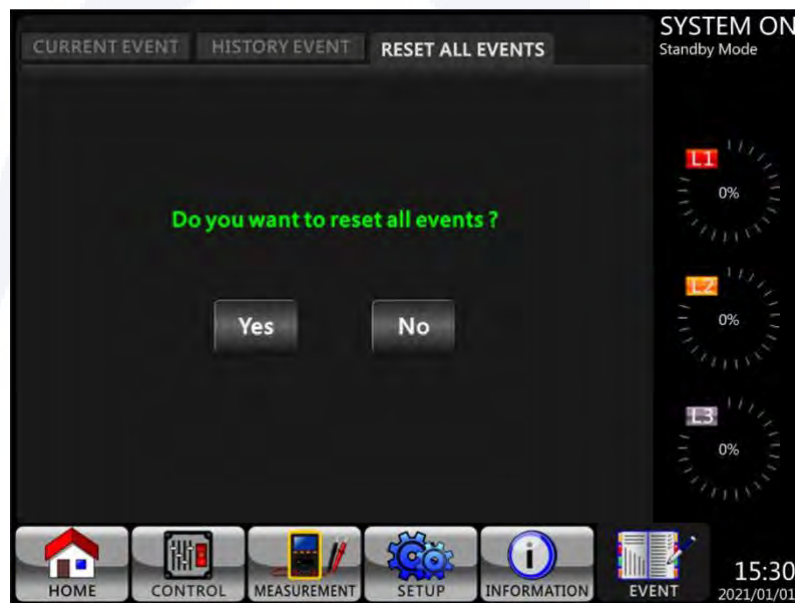

Figure 4-30 Reset All Events Confirmation screen

### 4.3 Alarm List

In **Table 4-12**, it provides the complete list of UPS alarm messages.

**Table 4-12:** Alarm List

<b>Representation in display LCD</b>	<b>Explanation</b>
Fault! <01>Bus start fail	BUS soft start failed
Fault! <02>Bus over	BUS voltage high
Fault! <03>Bus under	BUS voltage low
Fault! <04>Bus unbalance	BUS voltage unbalanced
Fault! <05>Bus dec fast	BUS voltage drop too fast
Fault! <06>Conv over cur	Converter over current
Fault! <11>INV start fail	Inverter soft start failed
Fault! <12>High INV VOL	Inverter voltage high
Fault! <13>Low INV VOL	Inverter voltage low
Fault! <14>INV A out SC	Phase A (Line to Neutral) output short circuited
Fault! <15>INV B out SC	Phase B (Line to Neutral) output short circuited
Fault! <16>INV C out SC	Phase C (Line to Neutral) output short circuited
Fault! <17>INV AB out SC	Phase A-Phase B (Line to Line) output short circuited
Fault! <18>INV BC out SC	Phase B-Phase C (Line to Line) output short circuited
Fault! <19>INV AC out SC	Phase C-Phase A (Line to Line) output short circuited
Fault! <1A>INV A N-fault	Phase A output negative power fault
Fault! <1B>INV B N-fault	Phase B output negative power fault
Fault! <1C>INV C N-fault	Phase C output negative power fault
Fault! <21>BATT SCR SC	Battery SCR short circuited
Fault! <23>INV relay open	Inverter relay open circuited
Fault! <25>In&out swop	Line wiring fault
Fault! <29>BATT fuse broken	Battery fuse open circuited
Fault! <31>Par commu fail	Parallel communication failed
Fault! <36>Par out cur unb	Parallel output current unbalanced
Fault! <41>Over temp	Over temperature
Fault! <42>DSP commu fail	DSP communication failed
Fault! <43>Overload	Heavy overload causes UPS fault
Fault! <45>Charger error	As stated.
Fault! <46>Incorrect UPS set	Incorrect UPS setting
Fault! <47>DSP&MCU commu fail	MCU communication failed
Fault! <49>In&out phase incomp	Input and output phase error
Fault! <61>BYP SCR SC	Bypass SCR short circuited
Fault! <62>BYP SCR open	Bypass SCR open circuited
Fault! <63>INV R wave abnormal	Voltage waveform abnormal in R phase
Fault! <64>INV S wave abnormal	Voltage waveform abnormal in S phase
Fault! <65>INV T wave abnormal	Voltage waveform abnormal in T phase
Fault! <66>CT saturation	As stated.
Fault! <67>BYP out SC	Bypass output short circuited
Fault! <68>BYP out line SC	Bypass output line to line short circuited
Fault! <69>INV SCR SC	Inverter Relay short circuited
Fault! <6C>Bus-VOL dec fast	BUS voltage drop too fast
Fault! <6D>CUR detect err	Current sampling error value
Fault! <6E>SPS Power fault	SPS Power fault
Fault! <6F>BATT reversal	Battery polarity reverse

Fault! <71>R PFC IGBT fault	PFC IGBT over-current in R phase
Fault! <72>S PFC IGBT fault	PFC IGBT over-current in S phase
Fault! <73>T PFC IGBT fault	PFC IGBT over-current in T phase
Fault! <74>R INV IGBT fault	INV IGBT over-current in R phase
Fault! <75>S INV IGBT fault	INV IGBT over-current in S phase
Fault! <76>T INV IGBT fault	INV IGBT over-current in T phase
Fault! <77> ISO Over temp	Isolation transformer over temperature
Fault! <79> Power Module Connect Fail	As stated.
Warning! <01> BATT open	Battery not connected
Warning! <02> IP N loss	Input N loss
Warning! <03> IP site fail	Input site failed
Warning! <04> Line phase error	As stated.
Warning! <05> Bypass phase error	As stated.
Warning! <06> Bypass FRE unstable	Bypass frequency unstable
Warning! <07> BATT over charge	Battery over charge
Warning! <08> BATT low	Battery voltage is too low
Warning! <09> Overload warning	As stated.
Warning! <0A> Fan lock warning	As stated.
Warning! <0B> EPO active	As stated.
Warning! <0D> Over temperature	As stated.
Warning! <10> L1 IP fuse fail	L1 Input fuse failed
Warning! <11> L2 IP fuse fail	L2 Input fuse failed
Warning! <12> L3 IP fuse fail	L3 Input fuse failed
Warning! <21> Line connect dif	Line connect different
Warning! <22> Bypass connect dif	Bypass connect different
Warning! <24> Par INV vol dif	Parallel output voltage setting different
Warning! <33> Lock BYP OL 3 times	Locked in bypass after overload 3 times in 30 min
Warning! <34> AC input CURR unb	Three-phase AC input current unbalanced
Warning! <35> Bat Phase loss	Battery phase loss
Warning! <36> INV CURR unb	Inverter current unbalanced
Warning! <3A> maintain is open	Cover of maintain switch is open
Warning! <3B> Auto Adapt Fail	Phase Auto Adapt failed
Warning! <3C> Utility ext unb	Utility extremely unbalanced
Warning! <3D> Bypass unstable	As stated.
Warning! <3E> BATT VOL High	Battery voltage is too High
Warning! <3F> BATT VOL Unbalance	Battery voltage unbalanced
Warning! <40> Charge Short	As stated.
Warning! <41> Bypass Loss	As stated.
Warning! <42> ISO Over temp	Isolation transformer over temperature
Warning! <43> BUS soft Error	BUS soft start failure
Warning! <44> Redundancy Error	As stated.
Warning! <45> cRedundancy OverLoad	As stated.
Warning! <46> EEPROM Fail	EEPROM operation error
Warning! <47> STS Lost	STS module loss
Warning! <48> Power module unlock	As stated.

## 4.4 History Record

**Table 4-13:** Important setting changed

Item No.	Description	Item No.	Description
1	Setup! Model Name	2	Setup! Turn On Password
3	Setup! Language	4	Setup! Change Turn On Password
5	Setup! Adjust Time	6	Setup! Nominal Power Display
7	Setup! System Installed Date	8	Setup! Output Voltage
9	Setup! System Last Maintain Date	10	Setup! Bypass Voltage Range
11	Setup! Battery Installed Date	12	Setup! Bypass Frequency Range
13	Setup! Battery Last Maintain Date	14	Setup! Converter Mode
15	Setup! Change Password	16	Setup! ECO Mode
17	Setup! Baud Rate	18	Setup! Bypass Mode
19	Setup! Audible Alarm	20	Setup! Auto-Restart
21	Setup! Factory Reset	22	Setup! Battery Mode Delay Time
23	Setup! EEPROM Reset	24	Setup! Shutdown Restore Time
25	Setup! EPO Function	26	Setup! Redundancy
27	Setup! Save Setting	28	Setup! Charger Test
29	Setup! Power Rating Setting	30	Setup! Battery Capacity in Ah
31	Setup! Nominal Battery Voltage	32	Setup! Battery Low Voltage
33	Setup! Maximum Charging Current	34	Setup! Battery Shutdown Voltage
35	Setup! Battery Low Capacity	36	Setup! Stop By Time
37	Setup! Periodic Battery Test	38	Setup! Temperature Compensation
39	Setup! BATTERY Age Alert	40	Setup! PRE-ALARM
41	Setup! Charging Voltage	42	Setup! Independent Battery
43	Setup! UPS Parallel	44	Setup! Auto-Restart Battery Voltage

**Table 4-14:** UPS mode change

Item No.	Description	Item No.	Description
1	UPS Mode! Power On Mode	2	UPS Mode! Standby Mode
3	UPS Mode! Bypass Mode	4	UPS Mode! Line Mode
5	UPS Mode! Battery Mode	6	UPS Mode! Battery Test Mode
7	UPS Mode! Fault Mode	8	UPS Mode! Converter Mode
9	UPS Mode! ECO Mode	10	UPS Mode! Shutdown Mode
11	UPS Mode! Un-Connection		

**Table 4-15:** Control execution

Item No.	Description	Item No.	Description
1	Control! System Turn On	2	Control! System Turn Off
3	Control! Manual Battery Test	4	Control! Cancel Battery Test
5	Control! Turn To Bypass	6	Control! Shutdown Restore
7	Control! Cancel Shutdown	8	Control! Charger Turn On
9	Control! Charger Turn Off		

# 5. Interface and Communication

As shown in figure 5-1, the Static Transfer Switch (STS) Module includes dry contact ports (X1~X8), Extra Comm. slot, SNMP slot, LCD connection port and serial communication ports (RS232 port, USB port) on the front panel.

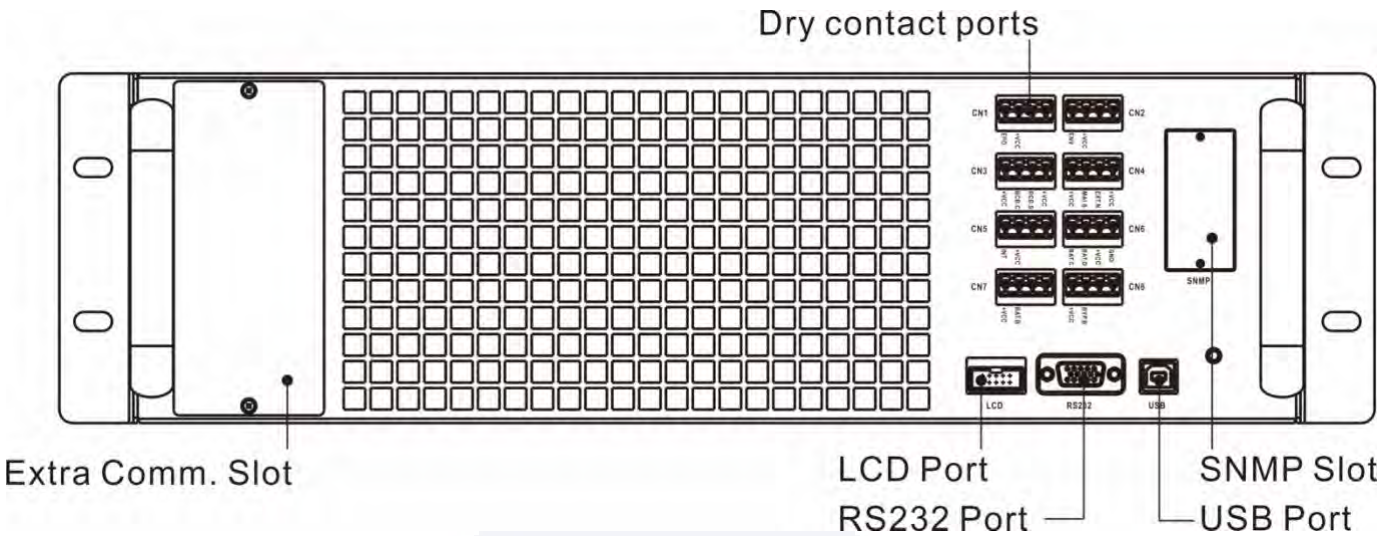

Figure 5-1 Front view of STS module

		Dry Contact No.	Function
	X1	X1	Remote EPO input port
	X2	X2	No use
	X3	X3	No use
	X4	X4	Maintenance Bypass Switch State Port
	X5	X5	No use
	X6	X6	Battery Cabinet Temperature Detection Port)
	X7	X7	No use
	X8	X8	No use

## 5.1 Dry Contact Port

### 5.1.1 X1-Remote EPO Input Port

The Emergency Power off (EPO) function in UPS can be operated by an assigned remote contact. Logic N.C. turns off the UPS.

X1 is the remote EPO input port. The port is shown in Figure 5-2 and described in **Table 5-1**.

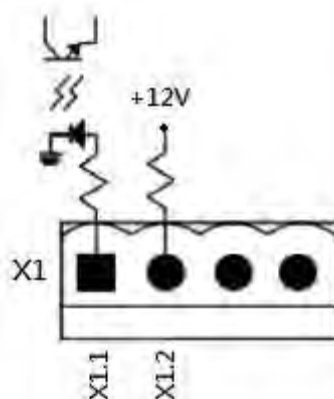

Figure 5-2 Remote EPO input port

**Table 5-1:** Description of remote EPO port

EPO Logic Setting	Position	Description
Short	X1.1 & X1.2	EPO is not activated when X1.1 & X1.2 shortened
Open	X1.1 & X1.2	EPO is activated when X1.1 & X1.2 opened

EPO Logic setting is Normal Closed (N.C), EPO is triggered when pins 1 and 2 of X1 are opened.

**Note:**

1. EPO function activates shutdown of the rectifiers, inverters and static transfer switch. But it does not internally disconnect the input power supply.

**5.1.2 X4-Maintenance Bypass Switch State Port**

X4 is the maintenance bypass switch port. The port is shown in Figure 5-3 and described in **Table 5-2**.

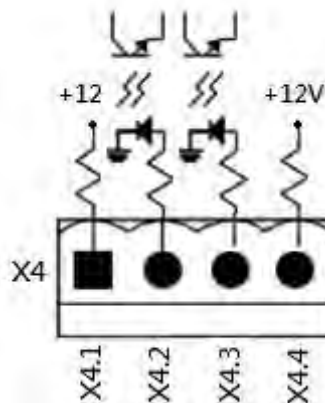

Figure 5-3 Maintenance Bypass Switch State port

**Table 5-2:** Description of Maintenance Bypass Switch State port

Name	Position	Description
Maintain Bypass Pin1	X4.1	Maintenance bypass switch state
Maintain Bypass Pin 2	X4.2	Maintenance bypass switch state
	X4.3	No use
	X4.4	No use

**5.1.3 X6-Battery Cabinet Temperature Detection Port**

There is battery cabinet temperature detection function in the UPS. The temperature of battery cabinet can be detected through the external battery cabinet temperature detection sensor. Communication between the UPS and Battery temperature detection board was through I2C communication protocol. X6 is the battery cabinet temperature detection port. The port is shown in Figure 5-4 and described in **Table 5-3**.

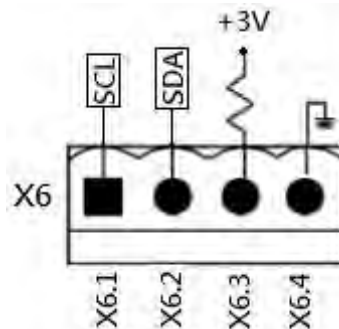

Figure 5-4 Battery Cabinet Temperature Detection port

**Table 5-3:** Description of Battery Cabinet Temperature Detection port

Name	Position	Description
SCL	X6.1	I <sup>2</sup> C communication SCL Signal
SDA	X6.2	I <sup>2</sup> C communication SDA Signal
+3.0V	X6.3	3V
Power GND	X6.4	GND

## 5.2 Extra Comm. Slot

There is an optional card called **Extra Comm. Card**. This card can be inserted into this slot to enhance the communication capability of the modular UPS. It provides an additional SNMP Slot, Dry contact I/P & O/P signals and temperature sensors ports.

## 5.3 Local Communication Ports – RS232 & USB

Simply use USB cable or RS232 cable to connect USB port or RS-232 port to the PC as local communication.

**Note:** The RS232 and USB ports can't work simultaneously.

## 5.4 SNMP Slot

The SNMP, AS400 or Modbus card can be inserted into this slot to work with the UPS.

## 6. Troubleshooting

Most of the Fault and Warning need to be released by authorized service personnel. Few of them can be solved by users themselves.

LCD Message	Explanation	Solution
Fault! Bus Over Voltage	DC bus voltage is too high	Contact service personnel.
Fault! Bus Under Voltage	DC bus voltage is too low	Contact service personnel.
Fault! Bus Voltage Unbalance	DC bus voltage is not balanced	Contact service personnel.
Fault! Bus Soft Start Time Out	The rectifiers could not start due to low DC bus voltage within specified duration	Turn off UPS and then restart the UPS. If it fails again, contact service personnel.
Fault! Inverter Soft Start Time Out	Inverter voltage cannot reach desired voltage within specified duration	Turn off UPS and then restart the UPS. If it fails again, contact service personnel.
Fault! Inverter Voltage High	Inverter Voltage is too high	Contact service personnel.
Fault! Inverter Voltage Low	Inverter Voltage is too Low	Contact service personnel.
Fault! R Inverter Voltage Short	R phase inverter Output is shorted	Contact service personnel.
Fault! S Inverter Voltage Short	S phase inverter Output is shorted	Contact service personnel.
Fault! T Inverter Voltage Short	T phase inverter Output is shorted	Contact service personnel.
Fault! RS Inverter Voltage Short	R-S inverter Output is shorted	Contact service personnel.
Fault! ST Inverter Voltage Short	S-T inverter Output is shorted	Contact service personnel.
Fault! TR Inverter Voltage Short	T-R inverter Output is shorted	Contact service personnel.
Fault! Inverter R Negative Power	R phase inverter Output Negative Power over range	Contact service personnel.
Fault! Inverter S Negative Power	S phase inverter Output Negative Power over range	Contact service personnel.
Fault! Inverter T Negative Power	T phase inverter Output Negative Power over range	Contact service personnel.
Fault! Over Load Fault	Heavy overload causes UPS fault.	Reduce some load.
Fault! Over Temperature	Make sure adequate space is allowed for air vents and the fan is working	Check if the ambient temperature is over specification. Or contact service personnel.
Fault! CAN Fault	CAN communication fault	Contact service personnel.
Fault! DSP MCU Stop Communicate	As stated.	Contact service personnel.
Fault! Bypass SCR Fault	As stated.	Contact service personnel.
Warning! EPO Active	Check the EPO connector	Check if the connector is loose when EPO acts abnormally.
Warning! Over Load Fail	The load devices are demanding more power than the UPS can supply. Line mode will transfer to Bypass mode.	Reduce some load and check output Load-Capacity and specification



Warning! Communicate CAN Fail	CAN communication error	Contact service personnel.
Warning! Over Load	In Line mode, the load devices are demanding more power than the UPS can supply.	Reduce some load and check output Load-Capacity and specification
Warning! Battery Open	Battery not connected	<ol style="list-style-type: none"> <li>1. Check battery breaker.</li> <li>2. Check if the battery connection is well connected.</li> <li>3. Check the setting of Nominal Battery voltage.</li> <li>4. Contact service personnel if necessary</li> </ol>
Warning! Battery voltage High	Battery voltage is too High	Check the setting of Nominal Battery voltage and contact service personnel.
Warning! Charge Fail	As stated.	Contact service personnel.
Warning! EEPROM Fail	EEPROM operation error	Contact service personnel.
Warning! Fan Lock	As stated.	Check if the fan is blocked or contact service personnel.
Warning! Line Phase Error	As stated.	Check if the Mains phase sequence is correct and contact service personnel.
Warning! Bypass Phase Error	As stated.	Check if the Bypass phase sequence is correct and contact service personnel.
Warning! N Loss	Neutral loss	Check if the Neutral connection is well and contact service personnel..
Warning! Redundancy Set Fail	As stated.	Check the redundancy setting is correct and contact service personnel.
Warning! Maintenance Bypass	Enter maintenance	Check if the connector is loose when it acts abnormally.

## 7. Service

This chapter introduces the UPS service, including the service procedures of the power module, STS & control module, battery module and the replacement of air filter.

### Warning:

1. Only the customer service engineers can service the power modules, STS module and battery modules.
2. Remove the power modules, STS module and battery modules from top to bottom to prevent cabinet from toppling due to high center of gravity.
3. **The static transfer switch (STS) module is NOT hot pluggable.** It should be replaced only when the UPS is in maintenance bypass mode or completely powered off.

### 7.1 Replacement Procedures Of Power Module

#### Warning:

- Confirm UPS is in Line mode or Bypass mode.
  - Confirm at least one Power Module remains in the UPS cabinet after one Power Module is removed
  - If all power modules have to be removed, the replacement **MUST** be under Maintenance Bypass Operation Mode.
1. Turn ready switch to "🔒" position
  2. The Power Module FAULT LED (RED) indicator is lit to indicate the Power Module output is off and disconnected from UPS system.
  3. Use a screwdriver to remove the four screws from fixing holes.
  4. Two people pull out together and remove the Power Module from its slot.
  5. After servicing the module, confirm that the DIP switch of the module is set correctly and the ready switch is in unready state "🔒".
  6. Push the module into the cabinet and tighten the screws on both sides. Turn ready switch to "🔓" position.
  7. The re-installed Power Module will be turned on automatically when UPS is in line mode.

### 7.2 Replacement Procedures Of STS Module

#### Warning:

- Confirm the UPS is operating in Maintenance Bypass Mode.
1. Follow Section "3.3.3.1 Transfer to maintenance bypass" procedure to transfer UPS into Maintenance Bypass operation.
  2. Remove the fixing screws on both sides of the front panel of the module and pull the module out from the cabinet.
  3. After servicing the module, push the module into the cabinet and tighten the screws on both sides.
  4. Follow chapter "3.3.3.2 Transfer to UPS Protection" procedure to transfer UPS into Bypass operation
  5. Press menu →control → system turn on →YES to turn UPS on.

### 7.3 Replacement Procedures Of Air Filter

As shown below, the UPS provides air filters on the back of the front door. Each filter is fixed by a fixing bar on both sides.

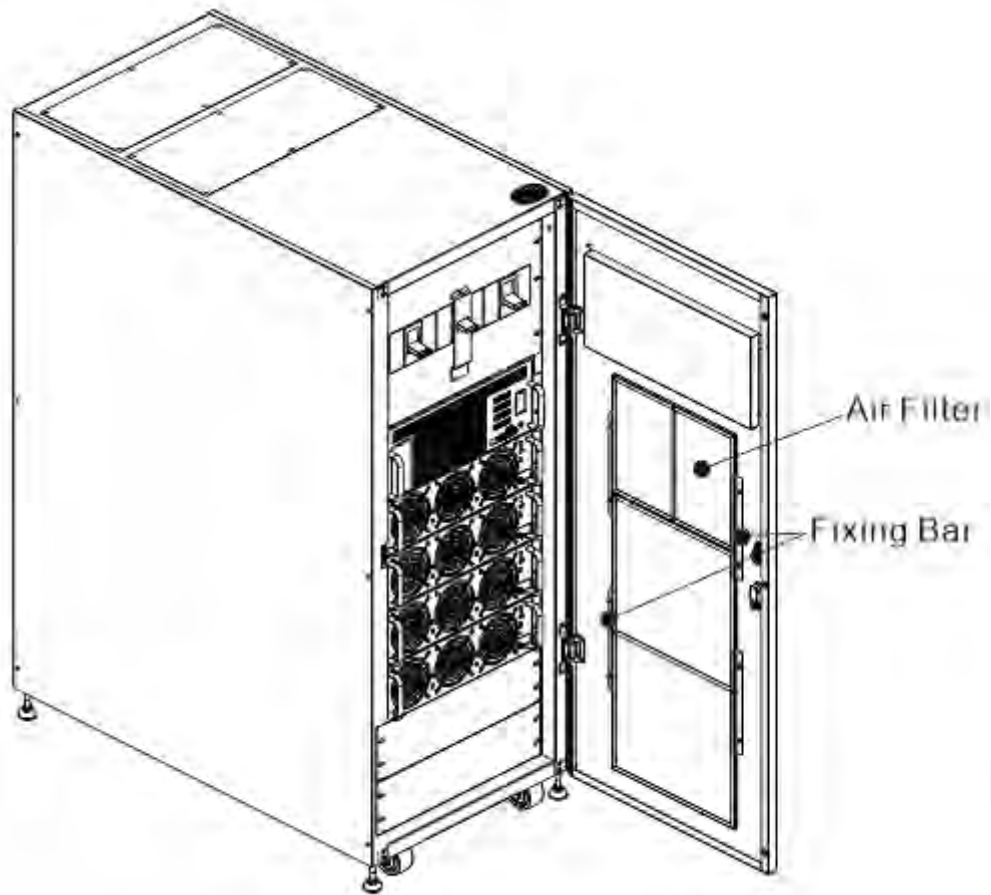

The replacement procedures of air filter are as follows:

1. Open the front door of the UPS and the air filters are on the back of the door.
2. Remove a fixing bar on either side of the air filter.
3. Remove the air filter, and insert a clean one.
4. Replace the fixing bar.

## 8. Specifications

The chapter states the specifications of UPS.

### 8.1 Conformity And Standards

The UPS has been designed to conform to the United State and international standards listed in **Table 8-1**.

**Table 8-1:** international standards

Item	Normative reference
Uninterruptible power systems (UPS) –Part 1: General and safety requirements for UPS	UL 1778: 2014 R8.15 CSA C22.2 No. 107.3-14
Electromagnetic compatibility (EMC) requirements for UPS	47 CFR FCC Rules and Regulations Part 15 Subpart B, Class A digital Device
Notes:	

### 8.2 Environmental Characteristics

**Table 8-2:** Environmental characteristics

Item	Unit	Specifications
Noise within 1 m	dB	Max. 75
Altitude	m	≤1000, derate power by 1% per 100m
Relative humidity	% RH	0 ~ 95, non-condensing
Operating temperature	°C	0 ~ 40°C
Storage and transport temperature for UPS	°C	-15 ~ 60

### 8.3 Mechanical Characteristics

**Table 8-3:** Mechanical characteristics

#### 42U

Model	Unit	42U-350				
Rated power	kVA/kW	70	140	210	280	350
Dimensions, W x D x H	mm	600 x 1100 x 2010				
Weight	kg	329	373	417	461	505
Color	N/A	Black				
Protection degree, IEC (60529)	N/A	IP20 (front door and back door is open or closed)				

Model	Unit	42U-700				
Rated power	kVA/kW	420	490	560	630	700
Dimensions, W x D x H	mm	900 x 1065 x 2000				
Weight	kg	769	813	857	901	945
Color	N/A	Black				
Protection degree, IEC (60529)	N/A	IP20 (front door and back door is open or closed)				

### 3U Power Module

Model	Unit	PM-70
Rated power	kVA/kW	70 KVA/70 KW
Dimensions, W x D x H	mm	750 x 438 x 130
Weight	kg	44

### 8.4 Electrical Characteristics (Input Rectifier)

**Table 8-4:** Rectifier AC input (mains)

Rated power (kVA)	Unit	70 ~ 700	
Rated AC input voltage	Vac	480 (three-phase three -wire, L-L,without neutral)	
Input voltage tolerance	Vac	330~528	
Frequency	Hz	50/60 (tolerance: 40Hz ~ 70Hz)	
Power factor	kW/kVA	0.99 full load	
Harmonic current distortion	THDI%	<4% full load	
Max. current / phase	A	70kVA/70kW	110
		140kVA/140kW	220
		210kVA/210kW	330
		280kVA/280kW	440
		350kVA/350kW	550
		420kVA/420kW	660
		490kVA/490kW	770
		560kVA/160kW	880
		630kVA/630kW	990
700kVA/700kW	1100		

### 8.5 Electrical Characteristics (Intermediate DC Circuit)

**Table 8-5:** Battery

Intermediate DC circuit		
Battery		External battery
Number of lead-acid cells	Nominal	216 (6cells x 36 12V battery block)
	Maximum	240 (6cells x 40 12V battery block)
	Minimum	192 (6cells x 32 12V battery block)
Float voltage	V/cell	2.28V/cell
Temperature compensation	mV/°C/cl	0~-5 (adjustable)
Boost voltage	VRLA	2.35V/cell
EOD voltage	V/cell	1.783V/cell default
Battery charge	V/cell	Constant current and constant voltage charge mode
Battery charging power <sup>1</sup> max current	A	18A / per power module (adjustable)

**Note:**

1. At low input voltage the UPS recharging capability increases and load decreases (up to the maximum capacity indicated).

## 8.6 Electrical Characteristics (Inverter Output)

**Table 8-6:** Inverter output (to critical load)

Rated power (kVA)	Unit	70 ~ 700	
Rated AC voltage <sup>1</sup>	Vac	480 (three-phase three -wire, L-L, without neutral)	
Frequency	Hz	50/60 Auto Selectable	
Overload	%	100%~110% for 60min 111%~125% for 10min 126%~150% for 1min >150% for 200ms	
Steady state voltage stability	%	±1 (balanced load), ±2 (100% unbalanced load)	
Total harmonic voltage	%	<2 (linear load), <5(non-linear load)	
Synchronization window		+/- 1Hz, +/- 2Hz, +/- 4Hz (default: 4Hz)	
Output rated current (@480V)	A	70kVA/70kW	84
		140kVA/140kW	168
		210kVA/210kW	252
		280kVA/280kW	336
		350kVA/350kW	420
		420kVA/420kW	504
		490kVA/490kW	588
		560kVA/160kW	672
		630kVA/630kW	756
700kVA/700kW	840		
Note: 1. Factory setting is 480V			

## 8.7 Electrical Characteristics (Bypass Mains Input)

**Table 8-7:** Bypass mains input

Rated power (kVA)	Unit	70 ~ 700	
Rated AC voltage <sup>1</sup>	Vac	480 (three-phase three -wire, L-L, without neutral)	
Overload	%	100%~110% for 60min 111%~125% for 10min 126%~150% for 1min >150% for 200ms	
Upstream protection, bypass line	N/A	Circuit breaker, rated up to 100% of nominal output current.	
Frequency	Hz	50/60 Auto Selectable	
Transfer time (between bypass and inverter)	ms	Inverter <->Bypass 0ms Inverter <->ECO ≤10ms	
Bypass voltage tolerance	%Vac	Upper limit: +10, default: +10 Lower limit: -10, -15, -20 default: -20	
Frequency Range	Hz	+/- 1Hz, +/- 2Hz, +/- 4Hz (default: 4Hz)	
<b>Note:</b> 1. Factory setting is 480V			